

Frontier West Virginia Inc.

Original Title

GENERAL SERVICES TARIFF

Containing

Regulations and Rates applicable to the furnishing of
General Telecommunications Services
for West Virginia
by
Frontier West Virginia Inc.

The name Verizon West Virginia Inc. has been changed to Frontier West Virginia Inc. All references throughout this Tariff to Verizon West Virginia Inc. "the Telephone Company" or "the company" shall be read as Frontier West Virginia Inc.

Issued by authority of an Order of the Public Service Commission of West Virginia
in Case No. _____ Dated _____.

Issued: January 8, 2001

Effective: January 8, 2001

GENERAL SERVICES TARIFF
P.S.C.-W.Va.-No. 203

Frontier West Virginia Inc.

Contents
8th Revised Page 1
Cancels 7th Revised Page 1

TABLE OF CONTENTS

	Section	
APPLICATION OF TARIFF.....	1	
CONSTRUCTION CHARGES.....	2	
EXCHANGE OPERATING SERVICES.....	2A	
SERVICE CHARGES.....	3	
DIRECTORY LISTINGS.....	4	
TELEPHONE DIRECTORIES.....	4B	
DISCOUNTS.....	5	
SUPPLEMENTAL EQUIPMENT.....	6	
CONVENIENCE FEE.....	7	
PREFERRED TELEPHONE NUMBER SERVICE.....	8	
DIRECTORY ASSISTANCE SERVICE.....	9	
NATIONAL DIRECTORY ASSISTANCE SERVICE.....	9B	
SERVICE REQUEST SERVICE.....	9C	
(RESERVED FOR FUTURE USE).....	9E	
CALL DIRECT AND MESSAGE SERVICE.....	9F	
SUSPENSION OF SERVICE - Grandfathered ²	10	(C)
SWITCHED 56 KILOBIT SERVICE.....	11	
CUSTOM REDIRECT SERVICE.....	12	
VACATION GET AWAY SERVICE.....	13	
DEDICATED PRI SERVICE.....	14	
DEDICATED BRI SERVICE - Grandfathered ¹	14A	
DEDICATED BRI SERVICE, RESIDENTIAL - Grandfathered ¹	14B	
DEDICATED PRI Plus Service, BUSINESS	14A-1	

¹ ISDN-BRI is grandfathered and limited to existing customers at existing locations as of March 18, 2022. Moves, additions or changes will not be permitted.

² Suspension of Service is limited to all existing customers at their existing locations as of June 4, 2022.

Issued by authority of an Order of the Public Service Commission of West Virginia in Case No. 22-0428-T-T dated May 9, 2022.

GENERAL SERVICES TARIFF
P.S.C.-W.Va.-No. 203

Frontier West Virginia Inc.

Contents
11th Revised Page 2
Cancels 10th Revised Page 2

TABLE OF CONTENTS

	<u>Section</u>	
CONCENTRATOR - IDENTIFIER EQUIPMENT.....	16	
TIME OF DAY SERVICE.....	18	
LOCAL CONFERENCE SERVICE.....	19	
OPERATOR ASSISTED LOCAL CALLS.....	20	
(RESERVED FOR FUTURE USE).....	20A	(C)
CUSTOM CALLING SERVICES.....	21	
OUTGOING CALL RESTRICT SERVICE.....	24	
DO NOT DISTURB.....	24A	
PROTECTION EQUIPMENT FOR SERVICES TO POWER STATIONS.....	25	
BUSINESS BASIC PLAN CALL ROUTING SERVICE.....	26	
VIRTUAL PRIVATE NETWORK SERVICE.....	27	
WORK-AT-HOME BILLING SERVICE (WAHBS).....	28	
INTERNET PROTOCOL ROUTING SERVICE.....	29	
ENHANCED DEDICATED SONET SERVICE.....	30	
SONET POINT-TO-POINT SERVICE	30A	
BUSINESS TRAFFIC STUDY SERVICE.....	31	
UNLIMITED LOCAL USAGE FOR BUSINESS.....	32	
UNLIMITED LOCAL AND TOLL USAGE FOR BUSINESS.....	33	
UNLIMITED DIAL TONE LINE (DTL) AND UNLIMITED COMMUNICATION SYSTEM.....	34	
SINGLE LINE BUSINESS PAK.....	35	
SOLUTIONS FOR BUSINESS BUNDLE.....	36	

* Effective February 18, 2005, Speech Recognition Service/Voice Dialing Service has been withdrawn and is no longer available.

Issued by authority of an Order of the Public Service Commission of West Virginia in Case No. 18-0080-T-T dated February 8, 2018.

Issued: January 31, 2018

Effective: March 2, 2018

GENERAL SERVICES TARIFF
P.S.C.-W.Va.-No. 203

Frontier West Virginia Inc.

Contents
6th Revised Page 3
Cancels 5th Revised Page 3

TABLE OF CONTENTS

	<u>Section</u>	
FRONTIER BUSINESS UNLIMITED SERVICE.....	37	
FRONTIER BUSINESS ESSENTIALS.....	38	
FRONTIER BUSINESS NATIONWIDE UNLIMITED SERVICE II ¹	39	(C)
FRONTIER BUSINESS LOCAL UNLIMITED II ¹	40	(C)
INTEGRATED SERVICES DIGITAL NETWORK (ISDN) PRIMARY RATE INTERFACE (PRI) BUNDLE SERVICE.....	41	
FRONTIER SIMPLY UNLIMITED SERVICE-LEADER ¹	42	(C)
FRONTIER SIMPLY UNLIMITED SERVICE-CHALLENGER ¹	43	(C)
FRONTIER ONEVOICE.....	44	
FRONTIER COMMERCIAL VOICE UNLIMITED ¹	45	(C)

¹ Effective January 20, 2018 this service offering is limited to existing subscribers. (N)
(N)

Issued by authority of an Order of the Public Service Commission of West Virginia
in Case No. 18-0013-T-T dated January 19, 2018.

Issued: January 5, 2018

Effective: January 20, 2018

GENERAL SERVICES TARIFF
P.S.C.-W.Va.-No. 203

Frontier West Virginia Inc.

Section 1
Original Page 1

APPLICATION OF TARIFF

A. GENERAL

This tariff applies to general telecommunications services furnished by Frontier West Virginia Inc. The regulations and rates contained herein are in addition to the applicable regulations and rates specified in other tariffs of the Telephone Company.

B. REGULATIONS

1. Use of Service

a. Resale of Service

A customer of the services, facilities and/or equipment in this tariff, except Centrex Service, may offer such services, facilities and/or equipment to others (patrons), for profit: provided the customer offering such service, facility and/or equipment to others is a certificated resale carrier certificated by the West Virginia Public Service Commission.

b. Sharing of Service

A customer of services, facilities and/or equipment in this tariff, except Centrex Service, may share such services, facilities and/or equipment in long term agreement with others (users). The customer may, but does not have to, use the service which is to be shared.

Sharing arrangements must be nonprofit. The total charges to all participants in a sharing arrangement may not exceed the sum of the Telephone Company's charges for the service shared, plus the charges for any ancillary equipment that may be connected to such shared service. The allocation of charges to each participant shall be on a nonprofit pro rata basis.

Where the customer for a sharing arrangement is organized as a nonprofit entity, a not-for-profit fee, charged solely for the management of the sharing arrangement, may be allocated by the customer among the participants.

Issued by authority of an Order of the Public Service Commission of West Virginia in Case No. _____ dated _____.

Issued: January 8, 2001

Effective: January 8, 2001

CONSTRUCTION CHARGES

A. GENERAL

Construction Charges are applicable to customers under certain conditions for the establishment or rearrangement of communications services when suitable plant facilities are not available or when the construction of the necessary facilities involves excessive costs.

B. REGULATIONS

1. Scope

- a. Construction Charges apply when one or more of the following conditions are present, and whenever more than one of such conditions are present, the charge for each condition applies, when the request for service requires:
 - (1) Construction for permanent service on private property to serve a single customer.
 - (2) Facilities, up to and including the network interface, of a type other than that which the Telephone Company would otherwise utilize in order to provide service for the customer.
 - (3) A greater quantity of facilities than that which the Telephone Company would otherwise construct in order to provide service for the customer.
 - (4) Routing of facilities other than that which the Telephone Company would normally utilize in order to provide service for the customer.
 - (5) The Telephone Company to expedite construction of the facilities at greater expense than would otherwise be incurred.
 - (6) Construction for temporary service and there is no immediate prospect of reusing the facilities provided.
 - (7) Distribution construction on continuous property for certain types of channels.
 - (8) The Telephone Company to relocate existing facilities at the request of the customer or other party.
- b. The term "poles" as used in this section includes the anchors, braces, guys, stubs and other fixtures required to support the poles.

Issued by authority of an Order of the Public Service Commission of West Virginia in Case No. _____ dated _____.

CONSTRUCTION CHARGES

B. REGULATIONS (Cont'd)

1. Scope (Cont'd)

- c. Construction charges apply in addition to the rate for the class of service furnished and any Service Charge, installation charge, nonrecurring charge, mileage charge or other similar charges that may apply.
- d. Where builders or developers require advance construction of facilities for the anticipated use of others, a guaranty or payment bond satisfactory to the Telephone Company to cover the cost of such construction, may be required before construction work is started.
- e. When a charge is applicable for construction on private property, the customer may undertake, where in the opinion of the Telephone Company it is practicable for him to do so, such construction in whole or in part, in lieu of the construction charges which apply. In all cases of construction by the customer, the material furnished and the method of construction are subject to the approval of the Telephone Company, no charge applying for the Telephone Company's supervision. When a portion of the construction is furnished by the customer, the network interface will be located at the point of connection with customer-provided facilities. No customer-owned facilities may be placed between facilities owned and maintained by the Telephone Company to the point of the network interface.
- f. Any poles, conduit, underground construction or other plant provided at the expense of the customer, shall not be used by the customer for any purpose other than service furnished by the Telephone Company or the support of cable, wire, or other apparatus of the Telephone Company, except upon approval of the Telephone Company.
- g. When a customer is so located that it is necessary to use a private right-of-way to furnish service, the customer is required to pay the entire costs involved in securing and maintaining such right-of-way.
- h. Construction Charges do not apply for construction of facilities to serve customers located on public roads if service can reasonably be provided using public road right-of-way as defined in the maps issued by the West Virginia Department of Highways. Trails and impassable public roads are not considered public roads for the purpose of administering these regulations.
- i. For the purpose of applying construction charges, persons, firms or corporations who share the same premises will be considered as a single customer when the Telephone Company can only reasonably expect to provide permanent service to a single customer at the premises in the future.

Issued by authority of an Order of the Public Service Commission of West Virginia
in Case No. _____ Dated _____ .

Issued: January 8, 2001

Effective: January 8, 2001

CONSTRUCTION CHARGES

B. REGULATIONS (Cont'd)

1. Scope (Cont'd)

j. Where restrictive covenants or other legal requirements adopted by the developer, home owners' association, community or any other person, firm or corporation mandate underground construction, the Telephone Company may, at its option, require the placement of conduit for its sole use, at the expense of the developer, home owners' association or other person, firm or corporation desiring the underground construction. All conduit must be placed in accordance with the specifications of the Telephone Company, in accordance with the requirements of the National Electrical Safety Code, and in accordance with any requirements of the Public Service Commission of West Virginia. The Telephone Company will have the right, but not the obligation, to repair, reconstruct, maintain or alter any conduit placed for its sole use. The provisions of this paragraph are in addition to any and all other requirements in the Telephone Company's applicable tariffs regarding conduit or trenching.

(N)
|
(N)

Issued by authority of an Order of the Public Service Commission of West Virginia
in Case No. _____ Dated _____.

CONSTRUCTION CHARGES

B. REGULATIONS (Cont'd)

2. Usual Construction for Permanent Service

The regulations contained herein contemplate usual construction, i.e., the type of construction which the Telephone Company would provide for the area and for the quantity and class of service involved if the decision rested solely with the Telephone Company. The Telephone Company will place either aerial or underground construction and will determine, in each case, which is the usual type of construction to be used to furnish service.

a. On Public Roads

Construction Charges do not apply. In all cases of usual construction on public roads to serve one or more customers or on private property to serve customers in general, ownership of the poles, conduit, and other plant must be vested either in the Telephone Company or some other company with which the Telephone Company has a joint use arrangement. All plant is maintained and replaced at the expense of the Telephone Company.

b. On Private Property

(1) Construction on private property, or which crosses or terminates on private property, which is to be used for four or more customers is furnished at the following rate.

(a) No charge is made for the first 2000 feet multiplied by the number of customers requesting facilities at any one time.

(b) Facilities with route distance in excess of (a) preceding, will be billed the entire cost of the job minus the allowable footage per customer, and such charges will be prorated equally among each customer within the group.

(2) Construction of communications services for one to three customers solely on private property, or which crosses or terminates on private property, is subject to the following regulations:

(a) The customer(s) is/are responsible for the construction of poles, conduit and underground construction on private property. Construction of such facilities may be provided in its entirety by the Telephone Company as specified in paragraph (c) following.

Issued by authority of an Order of the Public Service Commission of West Virginia in Case No. _____ dated _____.

CONSTRUCTION CHARGES

B. REGULATIONS (Cont'd)

2. Usual Construction for Permanent Service (Cont'd)

b. On Private Property (Cont'd)

(2) (Cont'd)

- (b) When the construction is provided by the customer(s), any poles, conduit and underground construction necessary to furnish service shall be maintained and replaced at the expense of the customer(s) and shall remain the property of the customer(s).

In case the customer(s) prefers to use the poles, conduit and underground construction of another company or individual and such poles, conduit and underground construction are suitable in the opinion of the Telephone Company, he may do so provided any attachment or other charges made for the use of such poles, conduit and underground construction are paid by the customer(s).

- (c) Where the construction is provided by the Telephone Company, either by constructing such plant or using the plant owned by another company with which the Telephone Company has a joint use arrangement, the construction charge is applied as follows:
- (I) No charge is made for the first 1000 feet route measurement of usual construction, per customer.
- (II) For the route distance in excess of 1000 feet per customer, the customer(s) is/are required to bear all reasonable cost of such construction.

The ownership of such poles or conduit will be vested either in the Telephone Company or some other company with which the Telephone Company has a joint use arrangement. All such plant is maintained and replaced at the expense of the Telephone Company.

- c. On Private Property to Serve a Single Customer with Multiple Facility Requirements and there is no other requirement for the facilities so constructed.

Issued by authority of an Order of the Public Service Commission of West Virginia in Case No. _____ dated _____.

CONSTRUCTION CHARGES

B. REGULATIONS (Cont'd)

2. Usual Construction for Permanent Service (Cont'd)

c. (Cont'd)

- (1) Where the construction is provided by the Telephone Company, either by constructing such plant or using the plant owned by another company with which the Telephone Company has a joint use arrangement, a termination charge based on an initial contract period of ten years will apply in addition to any applicable charges specified in b. preceding.
- (2) The maximum termination charge shall not exceed the estimated cost installed less the estimated net salvage and any nonrecurring charge applied at the start of service in accordance with b. preceding or 3. following for such construction.
- (3) Where the discontinuance of services and channels results in a reduction in the use of ten percent or more, but not all, of the total facilities initially provided, either of the following charge applications will apply, for the unexpired portion of the contract period:

For each ten percent reduction in the use of such facilities, the customer may elect to reduce the termination liability by paying 1/10th of the unexpired portion of the contract liability or pay a monthly recurring charge equal to 1/10th of the unexpired portion of the contract liability divided by the number of months remaining in the termination liability contract period. When a customer elects a recurring charge and the use of such facilities are restored, the applicable recurring charge will be discontinued.

- (4) To the extent that there is another requirement for such construction the termination charge specified in (1) preceding will not apply.

d. Refunds

When the construction for which the Telephone Company has made a cash construction charge is utilized by the Telephone Company for the purpose of serving additional customers within a period of three years from the date it was placed in service, refunds, without interest, will be made to those customers who have paid such charges, provided they are still served by such construction. The amount of such refunds to a particular customer will be based on the difference between the construction charge actually paid by that customer and the construction charge which he

Issued by authority of an Order of the Public Service Commission of West Virginia
in Case No. _____ Dated _____.

CONSTRUCTION CHARGES

B. REGULATIONS (Cont'd)

2. Usual Construction for Permanent Service (Cont'd)

d. Refunds (Cont'd)

would have paid if all customers served through that construction within such three-year period had been connected at the time the construction serving that customer was placed in service.

Where the construction is used within a period of three years for supporting local or long distance facilities connecting central offices, the total amount of cash construction charges paid by the customers will be refunded, without interest.

3. Special Construction for Permanent Service

a. When it is necessary for the Telephone Company to provide outside plant construction, either on a public road or on private property, up to the Network Interface, which is other than that usually provided for the area and class of service furnished, the customer or other party requiring such special construction is required to pay the difference between the estimated cost of usual construction and the estimated cost of the type of construction provided under the conditions specified herein. Such special construction includes:

- (1) underground construction where aerial construction would usually be provided,
- (2) submarine cable,
- (3) greater quantity or a different type of facilities than that which the Telephone Company would otherwise construct in order to fulfill the customer's initial requirements for service,
- (4) routing facilities different from that which the Telephone Company would normally utilize,
- (5) expedition of the construction of facilities at greater expense than would otherwise be incurred,

b. The Telephone Company will, in all cases, bear the same amount of the cost as in the case of usual construction provided under paragraph 2. preceding.

Issued by authority of an Order of the Public Service Commission of West Virginia in Case No. _____ dated _____.

CONSTRUCTION CHARGES

B. REGULATIONS (Cont'd)

3. Special Construction for Permanent Service (Cont'd)

b. (Cont'd)

(1) Outside Plant Construction

(a) On Public Roads or on Private Property

The customer or other party requiring the special construction is required to pay the difference between the total estimated cost of such special construction and the amount to be borne by the Telephone Company. All plant is maintained and replaced at the expense of the Telephone Company, except where poles or conduit are owned by the customer, in which case the customer is required to maintain such poles or conduit.

(b) Conduit and Trenching

Except as provided as usual construction by the Telephone Company, the provision, maintenance and replacement of conduit and underground construction on private property for one or more customers is the responsibility of the customer. The Telephone Company will install and maintain the associated wire facilities at its expense. The cost of conduit replacement or of opening and closing the trench in connection with the maintenance and replacement of the wire facilities shall be the responsibility of the customer.

(c) Provision of New Outside Plant

When a political subdivision of the State, or any agency thereof, requires by ordinance, franchise provision administrative ruling or otherwise that the Telephone Company place new facilities underground and this requires, in one or more instances, placing facilities underground where a type of construction other than underground would usually be provided, the difference between the estimated cost of the usual type of construction and the cost of placing facilities underground for each such instance will, insofar as reasonable and practicable, be charged pro rata to the exchange customers receiving service within the political subdivision. The charge shall be a uniform percentage of the customer's recurring monthly billing for telephone service and each monthly charge shall not exceed ten per cent of such billing.

Issued by authority of an Order of the Public Service Commission of West Virginia
in Case No. _____ dated _____.

CONSTRUCTION CHARGES

B. REGULATIONS (Cont'd)

3. Special Construction for Permanent Service (Cont'd)

b. (Cont'd)

(2) Facilities up to the Network Interface

- (a) It is the responsibility of the customer to provide a means of entrance into the building which is satisfactory to the Telephone Company and to provide space for mounting the necessary terminal and station protection equipment and, where riser cable is required, a reusable means to reach each floor and each suite or office on each floor where the telephone service is desired.

The Telephone Company will provide facilities, if required, to the nearest point of the customer's premises, which is satisfactory to the Telephone Company for placement of the network interface, within a building or structure.

- (b) Any required conduit or similar type construction involved in furnishing concealed wiring must be installed and maintained at the expense of the customer. Such construction must be installed in a manner which is acceptable to the Telephone Company.
- (c) Where, due to the type of construction of the building or the conditions imposed by the customer, abnormal expense is incurred by the Telephone Company, the customer is required to pay the difference between the estimated expense incurred by the Telephone Company and the estimated expense which would normally have been incurred for the installation.

4. Temporary Construction

When construction is required for temporary service (for a period less than 3 years), and there is no immediate prospect (within 6 months of service disconnection) of reusing the plant provided, the customer is required to bear all of the cost of such construction.

The regulations applying to ownership and maintenance of such temporary construction are the same as apply to usual construction for permanent service.

Issued by authority of an Order of the Public Service Commission of West Virginia in Case No. _____ dated _____.

Frontier West Virginia Inc.

Section 2
2nd Revised Page 9
Cancels 1st Revised Page 9

CONSTRUCTION CHARGES

B. REGULATIONS (Cont'd)

5. Rearrangement or Relocation of Existing Construction

- a. When the Telephone Company is requested to move or change existing construction, the customer or other party requiring the move or change is required to pay the actual cost incurred by the Telephone Company properly attributable to such relocation.
- b. When a political subdivision of the State, or any agency thereof, requires by ordinance franchise provision, administrative ruling or otherwise that existing aerial facilities be relocated underground, the entire cost incurred by the Telephone Company properly attributable to such relocation, after deducting therefrom any reimbursement received, any increase in value of the new facility and any salvage value derived from the old facility, will, insofar as reasonable and practicable, be charged pro rata to the exchange customers receiving service within the political subdivision. The charge shall be a uniform percentage of the customer's recurring monthly billing for telephone service and each monthly charge shall not exceed ten percent of such billing.
- c. When a political subdivision of the State, or any agency thereof, requires by ordinance, franchise provision, administrative ruling or otherwise that existing facilities be relocated due to an Urban Renewal or Slum Clearance Project, the entire cost incurred by the Telephone Company properly attributable to such relocation after deducting therefrom any reimbursement received, any increase in value of the new facilities and any salvage value derived from the old facilities, will, insofar as reasonable and practicable, be charged pro rata to the local exchange customers receiving service within the political subdivision. The charge shall be a uniform percentage of the customer's recurring monthly billing for telephone service and each monthly charge shall not exceed ten percent of such billing.

6. Charges Applicable for Facility Extension

When an applicant requests new service or upgraded service where construction of line facilities is required, the Telephone Company will cover the construction costs up to \$500.00. Any Construction charges over \$500.00 shall be recovered from the applicant. Construction charges for multicircuit customers will be on an ICB basis.

(N)
|
(N)

Issued by authority of an Order of the Public Service Commission of West Virginia in Case No. 23-0016-T-T dated January 18, 2023.

GENERAL SERVICES TARIFF
P.S.C.-W.Va.-No. 203

Frontier West Virginia Inc.

Section 2A
1st Revised Page 1
Cancels Original Page 1

EXCHANGE OPERATING SERVICES

A. GENERAL

Exchange Operating Services are performed by one Exchange Carrier (Operator Office Company) for a community dial office (CDO) exchange of another Exchange Carrier (CDO Company) (C)

B. REGULATIONS

Exchange operating services are provided as specified in the Operator Office Agreements.

C. RATES

1. Local Assistance Service, per work second \$.0125
2. Directory Assistance Service, per local originating call25 (T)
3. Intercept Services, per access line
 - a. CDO provides recorded intercept for all changed numbers, vacant levels, non-working numbers and discontinued services.....

	<u>Per</u>	
	<u>Month*</u>	<u>USOC</u>
	\$.08	
 - b. CDO office not equipped for recorded intercept as in a. Preceding..... .14 (T)

* The total monthly amount due the Operator Office Company from the CDO Company for each of the CDO exchanges for which it performs the exchange operating services will be determined as of the day the Operator Office Company starts to perform the exchange operating services.

Issued by authority of an Order of the Public Service Commission of West Virginia in Case No. _____ dated _____.

SERVICE CHARGES

A. GENERAL

Service Charges are those charges associated with work performed by the Telephone Company in connection with the provision of services or equipment for a customer.

B. REGULATIONS

1. Application of Service Charges

a. Order Processing Charge

An order Processing Charge applies per account for the processing of a customer request for service or equipment when such requests are received on the same day and are to be completed on the same date, excluding a customer request to renew or change an existing Variable Term Payment Plan period.

b. Line Charges

(1) Line Connection Charge

A Line Connection Charge applies for the connection of each exchange line, Private Branch Exchange (PBX) trunk, Wide Area Telephone Service (WATS) access line, Centrex line, and Channel Service except as otherwise specified in this tariff.

(2) Line Restoral Charge

A Line Restoral Charge applies for the restoral of service to each exchange line, PBX trunk or WATS access line suspended at the request of the customer.

c. Network Interface

(1) When it is required that a network interface, due to equipment limitations, be located at a point other than the initial point of entry, charges will apply as specified by the Telephone Company for the additional costs to install the network interface at the location required.

(2) When the network interface is located at a point other than the initial point of entry of Telephone Company service into the customer's premises, charges as specified by the Telephone Company will apply for all maintenance work performed from the initial point of entry to the extended location.

Issued by authority of an Order of the Public Service Commission of West Virginia
in Case No. _____ dated _____.

SERVICE CHARGES

B. REGULATIONS (Cont'd)

1. Application of Service Charges (Cont'd)

d. Premium Installation Appointment Charge

Premium installation appointments are offered only in Telephone Company selected areas subject to the following regulations.

- (1) A premium installation appointment is an offering which allows customers to schedule the installation of residence Local Exchange Service or WATS at their residences outside of the Telephone Company's regular working hours.
 - (2) A premium installation appointment is limited to the hours of 5:00 p.m. to 8:00 p.m. Monday through Friday during Daylight Saving Time, and on Saturday from 8:00 a.m. to 4:00 p.m.
 - (3) The provision of a premium installation appointment is based upon the current availability of the desired appointment, and the actual time of the appointment will be at the discretion of the Telephone Company.
 - (4) There will be no Premium Installation Appointment Charge applied for a customer-missed premium installation appointment.
 - (5) The customer will be notified of any premium installation appointment cancellation by the Telephone Company, and the customer will be offered another premium installation appointment without charge.
2. Service Charges are in addition to all other rates and charges that may be applicable for service provided by the Telephone Company.
3. Service Charges do not apply to work required for:
- a. Visits to a customer's premises solely for the purpose of repair, maintenance, or full or partial disconnection of Telephone Company provided service and equipment and no other chargeable activity is required.
 - b. Changes in class of service or grade of service.*

* Excluding a change from residence to business or vice versa.

Issued by authority of an Order of the Public Service Commission of West Virginia in Case No. _____ dated _____.

Frontier West Virginia Inc.

Section 3
4th Revised Page 3
Cancels 3rd Revised Page 3

SERVICE CHARGES

B. REGULATIONS (Cont'd)

3. Service Charges do not apply to work required for: (Cont'd)
 - d. A change from listed telephone service to Nonlisted or Nonpublished Telephone Service necessitated by communications which are received that are of an annoying, foul or profane nature.
 - e. A change from Nonlisted or Nonpublished Telephone Service to listed telephone service.
 - f. Changes to billing name, billing address, or listed name.
 - g. The initial establishment of the 700/900 Call Blocking Options on Residence or Business dial tone lines that are technically capable of providing this option.
 - h. Restricting a line from access to the usage capability of Custom Calling Services features that provide a per-use option.
 - i. The establishment of Custom Calling Service features.
 - j. The establishment of Long Distance Calling Plan Two-point Service or WATS Exchange Toll Free Service during Telephone Company-initiated sales campaigns, such campaigns not to exceed 60 consecutive days. (C)
 - k. The initial blocking of Service Request Service. (C)
 - l. The establishment of Toll Free Standard Service provided coincident with a new or relocated Local Exchange Service line; or as a result of a change from either Toll Free Basic Service or Toll Free Key Connections Service.
 - m. The establishment of the Local Package - Standard Option or the Local Package - Premium Option, a change from one Local Package option to the other Local Package option, or a change from the Local Package to another class of service.
 - n. Separation or combination of billing accounts.

Issued by authority of an Order of the Public Service Commission of West Virginia in Case No. 11-0799-T-T dated June 21, 2011.

Issued: June 2, 2011

Effective: July 2, 2011

SERVICE CHARGES

B. REGULATIONS (Cont'd)

4. Certain Service Charges do not apply to:

- a. The installation of miniature jacks placed solely to accommodate the maintenance changeout of customer-provided equipment associated with residence services or single-line business services. An Order Processing Charge is not applicable to this activity.
- b. Series 8000 Channel Services. Line Connection Charges are not applicable.
- c. The installation of Telecommunications Service Priority (TSP) System on an existing service, or priority level change on an existing TSP service, or for the change from Restoration Priority service to TSP service. An Order Processing Charge is not applicable.
- d. Big Deal transactions, including initial subscription and addition or deletion of features. An Order Processing Charge is not applicable.
- e. The Order Processing Charge and the Line Connection Charge are not applicable when the initial installation of Centrex Full Feature Business Voice System 2100 and Centrex Communication System lines are installed at tariff rates under a term commitment. (C)
(C)
- f. Order Processing, Line Connection and Record Order charges will not apply to the initial installation of business lines or trunks with a term commitment, or the conversion from month-to-month to a term plan for business lines or trunks.

GENERAL SERVICES TARIFF
P.S.C.-W.Va.-No. 203

Frontier West Virginia Inc.

Section 3
1st Revised Page 4
Cancels Original Page 4

SERVICE CHARGES

B. REGULATIONS (Cont'd)

(0)

(0)

Issued by authority of an Order of the Public Service Commission of West Virginia
in Case No. 12-0392-T-T dated April 19, 2012.

Issued: March 27, 2012

Effective: April 26, 2012

GENERAL SERVICES TARIFF
P.S.C.-W.Va.-No. 203

Frontier West Virginia Inc.

Section 3
2nd Revised Page 4a
Cancels 1st Revised Page 4a

SERVICE CHARGES

C. RATES

1. Order Processing Charge (See exceptions in B.3 preceding)

a. For the establishment of a customer account and the relocation of existing service to a different building		
Residence	\$18.00	
Business	*	
Pay Telephone Network Lines (PTNL)	\$53.70	
Customer-provided Coin and Credit Card Operated Telephones	\$60.50	(I)
b. For moving, changing or adding service on an existing business account.....	*	
c. For moving or changing service on an existing residence account excluding Custom Calling Service, additional listings, or an Optional Calling Plan.....	\$20.00	
d. For adding service on an existing residence account, excluding services specified in e. following.....	\$18.00	
e. Establish or change Voice Dialing Service, additional listings or an Optional Calling Plan on existing residence service only.	\$5.00	
f. Record Order Charge, for customer-initiated requests involving changes of Telephone Company records		
Residence	\$12.05	
Business	*	
Pay Telephone Network Lines	\$31.00	(I)
Customer-Provided Coin and Credit Card-Operated Telephones	\$28.50	

* Rates Deregulated.

Issued by authority of an Order of the Public Service Commission of West Virginia
in Case No. _____ dated _____.

Issued: June 16, 2009

Effective: July 1, 2009

GENERAL SERVICES TARIFF
P.S.C.-W.Va.-No. 203

Frontier West Virginia Inc.

Section 3
2nd Revised Page 5
Cancels 1st Revised Page 5

SERVICE CHARGES

C. RATES (Cont'd)

2. Line Charges

a. Line Connection Charges

(1) Exchange lines, each

Residence	\$24.00	
Business	*	
Customer-provided Coin and Credit Card-Operated Telephone Network Lines	\$26.50	(I)
Pay Telephone Network Lines	\$66.30	

(2) PBX trunks, each

Residence	\$33.00	
Business	*	

(3) WATS access lines, each

*

(4) Centrex lines, each

*

(5) Channel Services

(a) Series 2000, types 2006A, 2006B and 2006C, Channels ... None

(b) Series 2000, types 2011, 2041, 2045, Channels,
per channel

Residence	\$33.00	
Business	\$24.00	

(c) All other channels, per connection

\$24.00

b. Line Restoral Charge

Residence	\$9.90	
Business	\$12.00	(I)
Pay Telephone Network Lines	\$12.00	(I)

3. Premium Installation Appointment Charge..... \$48.00

* Rates Deregulated.

Issued by authority of an Order of the Public Service Commission of West Virginia
in Case No. _____ dated _____.

DIRECTORY LISTINGS

A. GENERAL

Primary and additional Directory Listings are provided in the alphabetical section of the telephone directory in accordance with the regulations and rates specified herein. Nothing in these regulations apply to or restrict paid directory advertising. (C)
(C)

B. REGULATIONS

1. Directory Listings are provided in connection with each customer service as specified herein. Network Controlled Inmate Lines; One-way, Outgoing Only Network Controlled Coin and Non-Coin Lines; and service associated with customer-provided audible indicating equipment are not listed in the directory.
2. The alphabetical section of the telephone directory consists of a list of names of customers in alphabetical order and is designed solely for the purpose of informing calling parties of the telephone numbers of customers and those entitled to use the customer's service as an aid to the use of telephone service, and special position or arrangement of names is not contemplated.
3. Listings must conform to the Telephone Company's specifications with respect to its directories.
 - a. The Telephone Company reserves the right to limit the length of any listing in the directory by the use of abbreviations when, in its judgment, the clearness of the listing or the identification of the customer is not impaired thereby. Where more than one line is required to properly list the customer, no additional charge is made.
 - b. The Telephone Company may refuse a listing which is known not to constitute a legally authorized or adopted name, or any listing which, in the opinion of the Telephone Company, is likely to mislead or deceive calling persons as to the identity of the listed party, or is a contrived name used for advertising purposes or to secure a preferential position in the directory or is more elaborate than is reasonably necessary to identify the listed party. The Telephone Company, upon notification to the customer, will withdraw any listing which is found to be in violation of its rules with respect thereto.
 - c. In connection with business service, a descriptive term characterizing the listed party's business in a general way, is furnished in abbreviated form as a part of the listing where desired. However, when the character of the listed party's business is already apparent from the form of the corporate or firm name, the business designation is unnecessary and is not furnished.

Issued by authority of an Order of the Public Service Commission of West Virginia in Case No. _____ dated _____.

DIRECTORY LISTINGS

B. REGULATIONS (Cont'd)

3. Listings must conform to the Telephone Company's specifications with respect to its directories (Cont'd)

d. In connection with residence service, the designation of residence is shown in abbreviated form as a part of the listing where desired, except that residence service furnished a physician, nurse, dentist or veterinary surgeon, or in a clergyman's study located in a church, may indicate the customer's profession, but only in connection with an individual name.

4. Primary Listings

a. One listing termed the primary listing, is provided without additional charge in connection with each customer service as follows:

(1) Individual line main service, service for Customer-Provided Coin and Credit Card-Operated Telephones, and Pay Telephone Network Lines, except Network Controlled Inmate Lines. Two or more individual lines consecutively numbered and arranged for group hunting constitute one customer service.

(2) Branch exchange, or similar system, or Centrex system.

(3) Mobile Telephone Service, per service.

(4) Special Reversed Charge Long Distance Service, per area selected.

(5) Remote Call Forwarding covering the exchange in which the call forwarding central office is located.

(6) Each dependent telephone number associated with a Distinctive Ring Custom Calling Service.

b. When the service is contracted for by one party for the use of a second party, the primary listing may be the name of the second party.

c. The primary listing for business service is ordinarily the name of the customer or the name under which a business is regularly conducted.

d. A residence dual name primary listing is comprised of a surname, two first names, address and telephone number. A residence dual name primary listing may be provided for two persons who share the same surname and reside at the same address, or for a person known by two first names.

Issued by authority of an Order of the Public Service Commission of West Virginia in Case No. _____ dated _____.

DIRECTORY LISTINGS

B. REGULATIONS (Cont'd)

5. Regular Additional Listings

- a. In connection with business and residence service, regular additional listings are available only in the names of authorized users of the customer's service as specified in the Telephone Company's applicable tariffs.
- b. Ordinarily, all additional listings are of the same address and telephone number as the primary listings, except as provided for joint user and alternate number listings. However, when it appears necessary as an aid to the use of the directory and provided satisfactory service can be furnished, a listing will be permitted under the address of a branch exchange, Centrex or extension of an exchange service line installed on premises of the customer, but at an address different from that of the attendant position or main service.
- c. Business additional listings are not permitted in connection with residence service.
- d. Business additional listings may be provided in connection with Mobile Telephone Service and Inward Service of Wide Area Telephone Service (WATS).
- e. Business additional listings may be provided in connection with Joint User Service with one additional listing offered at no charge for each joint user on a customer's service.
- f. Residence additional listings are also permitted in connection with business service which is located in a residence and for permanent guests residing in a hotel or club.
- g. A residence dual name additional listing is comprised of a surname, two first names, address and telephone number. A residence dual name additional listing may be provided for two persons who share the same surname and reside at the same address, or for a person known by two first names.

6. Special Types of Additional Listings

a. Alternate Number Listings

Alternate number listings refer calling parties to another telephone number at night and on Sundays and holidays, or in case no answer is received on the call to the primary number. If the alternate number is that of another customer's service, the consent of the other customer must be obtained before the alternate listing is provided.

Issued by authority of an Order of the Public Service Commission of West Virginia in Case No. _____ dated _____.

DIRECTORY LISTINGS

B. REGULATIONS (Cont'd)

6. Special Types of Additional Listings (Cont'd)

a. Alternate Number Listings (Cont'd)

Where two or more alternate number listings are furnished under one directive note or caption heading, the rate shall apply to each listing under the note or caption, but no charge applies for the note or caption itself.

b. Duplicate Listings

Duplicate listings, i.e., listings of nicknames, abbreviated names, names which are commonly spelled in more than one way, and rearrangements of names are permitted when, in the opinion of the Telephone Company, they are not desired to secure a preferential position in the directory or for advertising purposes.

(O)

(O)

c. Reference Listings

Reference listings consist of a name and a reference to another listing with or without a telephone number, but do not include an address. Such listings cover names which are commonly spelled in more than one way, names of formerly existing businesses which have been superseded by that of the customer, and rearrangement of names when, in the opinion of the Telephone Company, they are not desired to secure a preferential position in the directory or for advertising purposes.

(T)

7. Foreign Listing

A listing appearing in a directory other than the directory in which local exchange service is furnished or associated with a service provider that does not have a directory listing agreement in place.

(N)

8. Extra Line of Information

Descriptive text that does not have a telephone number.

(N)

Some material previously on this page now appears on 1st Revised Page 5.

Issued by authority of an Order of the Public Service Commission of West Virginia in Case No. 14-0420-T-T dated March 27, 2014.

DIRECTORY LISTINGS

B. REGULATIONS (Cont'd)

9. The initial contract period for additional listings, where the listing appears in the directory, is the directory period. Each directory period, with the appearance of the listing in the directory, will constitute a separate initial contract period. Listings are automatically included in each directory issue unless notice to the contrary is received from the customer. (M) (T)

Termination charges for additional listings, where the listing appears in the directory, are the charges due to the end of the directory period, except that in the following cases, the termination charges will be only the charges due for the period service has been rendered:

- a. The contract for the main service or Joint User Service is terminated.
 - b. The listed party contracts for service in his own name. (M)
 - c. The customer or listed party moves to a new location as a result of which the service of the customer is not available to the listed party.
 - d. The listed party dies.
10. The Telephone Company may publish of its own volition in its directories such notices, instructions, listings and other information pertaining to local or other governmental agencies as are necessary in its judgment to meet the convenience of the public. (T)
11. Centrex Service (T)
- The Telephone Company may furnish, without additional charge, informative wording associated with the primary listing to indicate that lines of the Centrex system may be dialed directly. Listings for Centrex dormitory lines will be provided at rates applicable for residence additional listings.
12. Foreign Zone Service (T)
- The primary listing is provided in the directory for the foreign zone.
13. Foreign Exchange Service (T)
- The primary listing is provided in the directory for the foreign exchange.
14. Special Reversed Charge Long Distance Service (T)
- The telephone number designation, with such explanatory notes, as in the judgment of the Telephone Company are necessary, will be listed in the directory of the selected area.

Some material appearing on this page previously appeared on Original Page 4.
Some material previously on this page now appears on 3rd Revised Page 6.

Issued by authority of an Order of the Public Service Commission of West Virginia in Case No. 14-0420-T-T dated March 27, 2014.

DIRECTORY LISTINGS

B. REGULATIONS (Cont'd)

15. Nonlisted Telephone Service

(M) (T)

A nonlisted telephone service will be furnished, at the customer's request, providing for the omission or deletion of the customer's telephone listing from the telephone directory. Such listings will be carried in the Telephone Company's directory assistance and other records and will be given to any calling party.

(M)

16. Nonpublished Telephone Service

(T)

A nonpublished telephone service will be furnished, at the customer's request providing for the omission or deletion of the customer's telephone listing from the telephone directory and, in addition, the customer's telephone listing will be omitted or deleted from the directory assistance records, subject to the provisions set forth following.

- a. The Telephone Company will not be liable for failure or refusal to complete any call to such telephone when the call is not placed by number.
- b. The Telephone Company will try to prevent the disclosure of the number of such telephone, but will not be liable should such number be divulged inadvertently; however,
- c. When a customer with Nonpublished Telephone Service places a call to the Universal Emergency Number 911 Service, the Telephone Company will release the name and address of the calling party, where such information can be determined, to the appropriate local governmental authority responsible for the Universal Emergency Number 911 Service upon request of such governmental authority.
- d. Calling line identification (CLI) may be provided to InterExchange Carriers and called customers who subscribe to services which use the CLI features.

17. Customers with line side or trunk side access to Telephone Company end office switches with an associated seven-digit telephone number for use in originating and receiving communications, as specified in this Company's applicable tariff, may be provided a Directory Listing at the rate specified herein for Regular and Special Types of Additional Listings, Business, for each listing so provided. (T)

Some material now appearing on this page previously appeared on Original Page 5.
Some material previously on this page now appears on 3rd Revised Page 7.

Issued by authority of an Order of the Public Service Commission of West Virginia in Case No. 14-0420-T-T dated March 27, 2014.

GENERAL SERVICES TARIFF
P.S.C.-W.Va.-No. 203

Frontier West Virginia Inc.

Section 4
6th Revised Page 7
Cancels 5th Revised Page 7

DIRECTORY LISTINGS

C. RATES

1. Regular and Special Types of Additional Listings

The following rates apply for regular and special types of additional listings and shall be effective at the time the listing is placed on the directory assistance records.

	Per <u>Month</u>
Business.....	\$8.94
Residence.....	.82
One business joint user listing, per joint user.....	None

2. Foreign Listings

The following rates apply for foreign listings and shall be effective at the time the listing is placed on the directory assistance records.

	Per <u>Month</u>	
Business.....	\$ 1.94	(I)
Residence.....	.82	

3. Extra Line of Information

The following rates apply for an extra line of information and shall be effective at the time the listing is placed on the directory assistance records.

	Per <u>Month</u>
Business.....	\$8.94
Residence.....	.82

Issued by authority of an order of the Public Service Commission of W.Va. in Case No. 24-0577-T-T dated July 15, 2024, effective August 15, 2024.

DIRECTORY LISTINGS

C. RATES (Cont'd)

(M)

4. Nonlisted and Nonpublished Telephone Service (T)

When a change from listed telephone service to Nonlisted or Nonpublished Telephone Service is necessitated by the receipt of annoyance calls, or communications which are received that are of a foul or profane nature, the monthly charge will not apply for a period not to exceed 90 days.

	Per <u>Month</u>	(T)
Nonlisted Telephone Service.....	\$1.57	(I)
Nonpublished Telephone Service.....	2.52	(I) (T)

Nonlisted and nonpublished charges, as specified following, are not applicable to:

- a. Nonlisted or Nonpublished Telephone Service furnished to a customer for data service where there is no voice use contemplated.
- b. Nonlisted or Nonpublished Telephone Service furnished to a customer for short periods of time, usually one day, in connection with local and long distance message broadcasts of sporting events, conventions or other special events.
- c. Nonlisted or Nonpublished Telephone Service furnished to a customer with other listed, nonlisted or nonpublished service in the same directory area.
- d. Nonlisted or Nonpublished Telephone Service associated with Mobile Telephone Service, Service for Customer-Provided Coin and Credit Card-Operated Telephones, and Pay Telephone Network Lines.
- e. Nonlisted or Nonpublished Telephone Service associated with dependent telephone numbers of a Distinctive Ring Custom Calling Service.

(M)

Material appearing on this page previously appeared on 2nd Revised Page 7.

Issued by authority of an Order of the Public Service Commission of West Virginia in Case No. 14-0420-T-T dated March 27, 2014.

GENERAL SERVICES TARIFF
P.S.C.-W.Va.-No. 203

Frontier West Virginia Inc.

Section 4A
1st Revised Page 1
Cancels Original Page 1

List Service formerly found in this section is hereby cancelled and withdrawn.

Issued by authority of an Order of the Public Service Commission of West Virginia
in Case No. _____ dated _____.

Issued: April 4, 2003

Effective: April 19, 2003

TELEPHONE DIRECTORIES

A. GENERAL

Telephone directories are furnished, in limited quantity, free of charge, for directory information relative to the customer's local service area.

As a customer service, the Telephone Company will provide Independent Telephone Company directories to customers who request them at rates that are the actual cost paid by Verizon. Those rates are published annually in the Telephone Directory Wholesale Price Catalog. The actual shipping costs incurred will also be paid by the customer requesting the directories.

B. REGULATIONS

Local Directories will be furnished in reasonable quantities as determined by the Telephone Company. Independent Telephone Company directories will be provided at the actual cost to Verizon. The Yellow Page Publishers Association publishes annually the Telephone Directory Wholesale Price Catalog that shows the current rates. Actual shipping costs incurred will also be paid by the customer requesting the directories.

C. RATES

Customers requesting Independent Telephone Company directories are required to pay the actual cost charged to Frontier for the directories plus the actual shipping cost.

DISCOUNTS

A. GENERAL

Employees of this Company and of its Associated Telephone Companies are allowed discounts as specified for exchange telephone service.

B. REGULATIONS

1. Discounts apply on the monthly rates for local exchange telephone service including local messages and associated exchange services such as additional directory listings, mileage, supplemental equipment, and special equipment and service arrangements, etc.
2. No discount will be allowed on service charges for the establishment and move of service, installation charges, charges for restoral of service, construction charges, telegrams, or charges for long distance services.
3. Employees are allowed a 50% discount for service specified in 1. preceding at their residences.
 - a. The service must be for the use of the employee or his immediate family only and its use by others will not be permitted.
 - b. The term "employee" as used in this section includes all employees except those classified as temporary or occasional and those who are paid on a commission basis.

Issued by authority of an Order of the Public Service Commission of West Virginia in Case No. _____ dated _____.

GENERAL SERVICES TARIFF
P.S.C.-W.Va.-No. 203

Frontier West Virginia Inc.

Section 6
1st Revised Page 1
Cancels Original Page 1

SUPPLEMENTAL EQUIPMENT

<u>INDEX</u>	<u>Page</u>
Apartment Door Answering Service.....	2
Break Rotary Hunt Arrangement.....	6
Call Restriction Service.....	21
Central Office Data Sets.....	18
Direct Inward Dialing (DID) Service.....	3
Hunting Service Arrangements.....	10
Identified Outward Dialing (IOD) Service.....	4
Long Distance Message Restriction.....	7
Make-busy Arrangements.....	9
Messaging Services Interface/Premier Messaging Services Interface.....	12
PBX Night, Sunday and Holiday Service Arrangements.....	5
Ring Count Change Information.....	22
700/900 Call Restriction Service.....	19
Special Billing Numbers.....	14
Split Supervisory Drop Wire Arrangement.....	11
Three-way Call Transfer.....	23
Transfer Arrangements.....	17
Uniform Call Distribution Service.....	20

(D)

Issued by authority of an Order of the Public Service Commission of West Virginia
in Case No. _____ dated _____.

Issued: June 19, 2001

Effective: July 20, 2001

SUPPLEMENTAL EQUIPMENT

Apartment Door Answering Service (LA-3)

A. General

Apartment Door Answering Service is offered as a communications system for apartment buildings, which provides the capability for tenants to identify and admit visitors while remaining in their apartments. Included in the system are:

1. A tenant's capability of releasing a lobby door relay by dialing a specified code.
2. An automatic call waiting tone, audible to the tenant only, for notification of either incoming exchange or lobby entrance calls when the other is in progress.
3. A hold and answer capability, by switchhook depression at the tenant's telephone, for pickup of either exchange or lobby entrance calls when the other is in progress.
4. Automatic ringback, at the tenant's telephone, if held calls are not returned to.

B. Regulations

1. The customer of Apartment Door Answering Service is the building owner or management, to whom all charges are billed.
2. Use of Apartment Door Answering Service is limited to one customer for each common equipment, with a maximum capacity of four lobby telephones and 400 apartment units.
3. Where there is more than one exchange service line in an apartment, door answering service will be associated with only one of the lines.
4. The service is provided only if furnished in all units in the apartment house.
5. No measured charges apply for calls between the lobby telephones and the apartments.
6. Apartment Door Answering Service may be furnished in connection with individual line service and is provided at all stations connected to the line that are within the tenant's apartment.

Issued by authority of an Order of the Public Service Commission of West Virginia in Case No. _____ dated _____.

GENERAL SERVICES TARIFF
P.S.C.-W.Va.-No. 203

Frontier West Virginia Inc.

Section 6
Original Page 2a

SUPPLEMENTAL EQUIPMENT

Apartment Door Answering Service (LA-3)

B. Regulations (Cont'd)

7. Liability of the Telephone Company

- a. The offering of Apartment Door Answering Service does not create any relationship or obligation, direct or indirect, to any person other than the customer to this service. The obligation of the Telephone Company is limited to the extent of providing facilities suitable for ordinary telephone service and maintaining and operating those facilities in a manner proper for such service.

- b. The Telephone Company has no responsibility with respect to the suitability of any equipment not furnished by the Telephone Company, the use of such equipment in connection with the Telephone Company's facilities, and any other obligation of the customer as set forth preceding. The use of the customer's door latch equipment in connection with the facilities of the Telephone Company is permitted on the condition that the Telephone Company shall not be responsible to the customer or any other person for damages arising out of mistakes, omissions, interruptions, delays or errors or defects in transmission, or failure or defects in the Telephone Company equipment furnished for Apartment Door Answering Service, except as provided for in the preceding paragraph. The liability of the Telephone Company for damages caused by its failure to furnish facilities suitable for telephone service or to maintain and operate such facilities in a manner proper for such service is as set forth in this Company's General Regulations Tariff, Section 1.

C. Rates

	Installation Charge	Per Month	USOC
1. Common Equipment, with a maximum capacity of 400 apartment connections and four lobby telephones, including the required channel facilities between the first lobby telephone and the central office, each.....	\$195.63	\$176.63	AXT
2. Channel Facilities, between an additional lobby telephone and central office, each.....	3.35*	20.68	ZZFGA
3. Relay Equipment, each apartment.....	-	1.73	RLD

* Applicable only to installations or moves, including the first lobby telephone made subsequent to the installation of service.

Issued by authority of an Order of the Public Service Commission of West Virginia in Case No. _____ dated _____.

SUPPLEMENTAL EQUIPMENT

Direct Inward Dialing (DID) Service

A. General

DID Service provides for inward dialing from the telecommunications network directly to lines associated with switching equipment located on the customer's premises.

B. Regulations

1. DID Service requires special equipment and will be provided only where DID facilities are available in the central office and the switching equipment located on the customer's premises is properly equipped for DID Service.

When modifications to the central office equipment are required in excess of those contemplated by the rates and charges specified herein, charges based on the estimated costs of the specially constructed equipment apply if the equipment has the capability to be modified. Such charges will be determined in accordance with (a) following, unless the customer elects the alternative charges specified in (b) following, and notifies the Telephone Company of such election in writing prior to the start of such special construction.

- a. Charges equal to the estimated costs of the specially constructed equipment apply as follows:

- (1) An initial nonrecurring charge applies at the start of service equal to the cost installed.

If any element of the specially constructed equipment is replaced subsequent to the start of service and the cost of such replacement is chargeable to the capital accounts of the Telephone Company, a nonrecurring replacement charge applies. The Telephone Company shall notify the customer in writing of the need for such replacement and such replacement shall not be undertaken until the Telephone Company has received written authorization from the customer.

- (2) Monthly rates apply equal to the recurring monthly costs. For purposes of this paragraph, recurring monthly costs include the estimated costs of maintenance, depreciation, administration, taxes, return on investment and any other items of cost applicable to the specially constructed facilities, but do not include provision for depreciation, return on investment and federal income tax on any portion of the investment as to which a nonrecurring charge applies pursuant to (1) preceding.

Issued by authority of an Order of the Public Service Commission of West Virginia in Case No. _____ dated _____.

SUPPLEMENTAL EQUIPMENT

Direct Inward Dialing (DID) Service

B. Regulations (Cont'd)

1. (Cont'd)

a. (Cont'd)

(3) In the event charges are applicable pursuant to both (1) and (2) preceding, an additional monthly rate applies equal to ten percent of the estimated recurring monthly costs of maintenance, administration and taxes, other than federal income tax, associated with any portion of the investment as to which a nonrecurring charge applies pursuant to (1) preceding.

b. As an alternative to the charges specified in (a) preceding, charges equal to the estimated costs of the specially constructed equipment apply as follows:

Any such costs, whether in the costs installed or in the recurring monthly costs, or both, shall be recovered by a monthly rate which shall include the estimated excess cost of maintenance, depreciation, administration, taxes, return on investment, federal income tax and any other items of costs applicable to the specially constructed equipment.

2. DID Service must be provided on all trunks in a group arranged for inward service. Routing of calls to selected numbers within the DID number group over a separate trunk group is not contemplated, except for the first number of a DID number group which may be routed to a separate trunk outside of this trunk group. This number will be included as part of the total initial number group of 20.
3. Customer-provided switching systems with which DID Service is associated must be arranged by the customer to provide for the intercepting of assigned but unused line numbers.
4. Where DID Service is requested from more than one wire center or from separate trunk groups within the same wire center, such service provided from each wire center or each trunk group within the same wire center shall be considered a separate service.

Issued by authority of an Order of the Public Service Commission of West Virginia in Case No. _____ dated _____.

GENERAL SERVICES TARIFF
P.S.C.-W.Va.-No. 203

Frontier West Virginia Inc.

Section 6
2nd Revised Page 3b
Cancels 1st Revised Page 3b

SUPPLEMENTAL EQUIPMENT

Direct Inward Dialing (DID) Service

B. Regulations (Cont'd)

5. DID Service is furnished upon the condition that the customer obtain adequate facilities to permit the use of DID Service without injurious effect upon it or any other services rendered by the Telephone Company. The Telephone Company may terminate or refuse to furnish service to any customer, without incurring any liability, if the use of the service would interfere with or impair other services provided by the Telephone Company, provided that, in the case of a termination of service, at least five days have elapsed following written notification to the customer by mail, or in person, of the Telephone Company's intention to terminate the service for such cause.

6. In the event that two or more customers in the same exchange require use of equipment constructed at customer expense for provision of DID service the costs for the portion of the equipment which is common to provision of the service to all such customers will be borne equitably by all such customers. Such equitable distribution of common costs may require the transfer of sums of money between customers. Discontinuance of use of DID service shall not qualify a customer for a refund of any portion of any amount paid for noncustomer-premise equipment necessary for provision of DID service. If any customer disagrees with the Telephone Company's decision regarding the previous referenced equitable distribution of common costs, that customer shall promptly ask the Public Service Commission of West Virginia to review the matter and issue such order as is appropriate.

C. Rates

DID Service for:	<u>Installation Charge</u>	<u>Per Month</u>	<u>USOC</u>	
First 20 DID Line Numbers.....	**	**	NDZ	(O)
Each Additional 20 DID Line Numbers.....	**	**	NDJ	(O)
DID Central Office Trunk Connection, per trunk*.....	**	**	NDT	(O)

* In addition, rates and charges apply as specified for PBX Trunks in this Company's Local Exchange Services Tariff.

** Rates deregulated.

Issued by authority of an Order of the Public Service Commission of West Virginia in Case No. 06-0481-T-PC dated 02/07/07.

SUPPLEMENTAL EQUIPMENT

Identified Outward Dialing (IOD) Service (LA-3)

A. Regulations

1. IOD Service provides for line number identification of outgoing long distance messages originated from lines associated with switching equipment located on the customer's premises. IOD Service requires special equipment and will be provided only where IOD facilities and telephone numbers are available in the central office and the switching equipment located on the customer's premises is properly equipped for IOD Service.

When modifications to the central office equipment are required in excess of those contemplated by the rates and charges specified herein, charges based on the estimated costs of the specially constructed equipment apply if the equipment has the capability to be modified. Such charges will be determined in accordance with (a) following, unless the customer elects the alternative charges specified in (b) following, and notifies the Telephone Company of such election in writing prior to the start of such special construction.

- a. Charges equal to the estimated costs of the specially constructed equipment apply as follows:

- (1) An initial nonrecurring charge applies at the start of service equal to the cost installed.

If any element of the specially constructed equipment is replaced subsequent to the start of service and the cost of such replacement is chargeable to the capital accounts of the Telephone Company, a nonrecurring replacement charge applies. The Telephone Company shall notify the customer in writing of the need for such replacement and such replacement shall not be undertaken until the Telephone Company has received written authorization from the customer.

- (2) Monthly rates apply equal to the recurring monthly costs. For purposes of this paragraph, recurring monthly costs include the estimated costs of maintenance, depreciation, administration, taxes, return on investment and any other items of cost applicable to the specially constructed facilities, but do not include provision for depreciation, return on investment and federal income tax on any portion of the investment as to which a nonrecurring charge applies pursuant to (1) preceding.
- (3) In the event charges are applicable pursuant to both (1) and (2) preceding, an additional monthly rate applies equal to ten percent of the estimated recurring monthly costs of maintenance, administration and taxes, other than federal income tax, associated with any portion of the investment as to which a nonrecurring charge applies pursuant to (1) preceding.

Issued by authority of an Order of the Public Service Commission of West Virginia in Case No. _____ dated _____.

SUPPLEMENTAL EQUIPMENT

Identified Outward Dialing (IOD) Service (LA-3)

A. Regulations (Cont'd)

1. (Cont'd)

- b. As an alternative to the charges specified in (a) preceding, charges equal to the estimated costs of the specially constructed equipment apply as follows:

Any such costs, whether in the costs installed or in the recurring monthly costs, or both, shall be recovered by a monthly rate which shall include the estimated excess cost of maintenance, depreciation, administration, taxes, return on investment, federal income tax and any other items of costs applicable to the specially constructed equipment.

- 2. IOD Service must be provided on all trunks in a group arranged for outward service.
- 3. Where IOD is requested on more than one group of trunks, each such group shall be considered a separate service.
- 4. In the event that two or more customers in the same exchange require use of equipment constructed at customer expense for provision of IOD service, the costs for the portion of the equipment which is common to provision of the service to all such customers will be borne equitably by all such customers. Such equitable distribution of common costs may require the transfer of sums of money between customers. Discontinuance of use of IOD service shall not qualify a customer for a refund of any portion of any amount paid for noncustomer-premise equipment necessary for provision of IOD service. If any customer disagrees with the telephone company's decision regarding the above-referenced equitable distribution of common costs, that customer shall promptly ask the Public Service Commission of West Virginia to review the matter and issue such order as is appropriate.

B. Rates

IOD Service for:*	Installation Charge	Per Month	Termination Charge	USOC
First 10 trunks in a group, including data link (minimum charge is for ten trunks).....	\$122.97	\$366.67	\$10,865.99(36)	NDK
11th trunk in a group through the 50th trunk, per trunk.....	12.30	35.77	1,046.35(36)	NDL
51st trunk and each subsequent trunk in a group, per trunk.....	12.30	6.60	201.22(36)	NDM

* In addition, rates and charges apply as specified for PBX trunks in this Company's Local Exchange Services Tariff.

Issued by authority of an Order of the Public Service Commission of West Virginia in Case No. _____ dated _____.

SUPPLEMENTAL EQUIPMENT

PBX Night, Sunday and Holiday Service Arrangements (LA-3)

A. Regulations

1. Under this plan, the customer connects a particular PBX Line either to a nonsequence trunk not otherwise listed in the telephone directory, or to a regular trunk with which a special telephone number is associated at the central office. The telephone number of the nonsequence trunk or special telephone number is listed in the directory as an alternate number listing.
2. In order that persons who have not observed the alternate number listings for this service in the telephone directory and who use the regular telephone number assignment in making calls at night and on Sunday and holidays may receive a response from the called person, the PBX customer is expected to connect to the trunk, the telephone number of which is associated with the main listing in the telephone directory, the PBX Line best located so as to be available for general information.
3. Alternate number listings, adequate to enable telephone users to properly place calls to the PBX Service of the customer, shall be arranged for with the Telephone Company by the customer.

B. Rates

1. Alternate Number Listings

Note specifying hours of service,
"Night Calls" or "Nights, Sundays
and Holidays Call" and for listings
inserted under note.....

Rates are as for Addi-
tional Directory List-
ings in this tariff.

	Per <u>Month</u>	<u>USOC</u>
2. Special Central Office Equipment Arrangement		
(a) Where a nonsequence trunk is used.....	None	-
(b) In all other cases, for each special telephone number.....	\$6.82	NCB

Issued by authority of an Order of the Public Service Commission of West Virginia
in Case No. _____ dated _____.

SUPPLEMENTAL EQUIPMENT

Break Rotary Hunt Arrangement

A. General

Break Rotary Hunt Arrangements are furnished to enable customers to stop switching equipment from hunting beyond a designated line in an incoming rotary line group utilizing a control arrangement on the customer's premises and a control channel between the network Interface and the associated switching equipment located on the Telephone Company's premises.

B. Regulations

Break Rotary Hunt Arrangements are furnished only in connection with PBX trunks, individual lines, Toll Free Service access lines, and Centrex lines which are grouped for incoming service.

C. Rates

	<u>Installation Charge</u>	<u>Per Month</u>	<u>USOC</u>
Break Rotary Hunt Arrangement, each*.....	\$12.30	\$46.39	93B

* In addition, rates apply as specified for a Series 1000, type 1001, Channel in this Company's Channel Services Tariff, Section 2, and a control arrangement is required.

Issued by authority of an Order of the Public Service Commission of West Virginia in Case No. _____ dated _____.

SUPPLEMENTAL EQUIPMENT

Long Distance Message Restriction

A. General

Long Distance Message Restriction is an arrangement which permits an exchange service line or communications system to dial local service area calls but prevents the origination of long distance calls. In addition, this arrangement denies the user access to "ZERO" (operator) dialing.

B. Regulations

1. Long Distance Message Restriction is provided for use only on individual line exchange service in areas where 911 Service is available. In areas where 911 Service is not available Long Distance Message Restriction is provided only where the customer has other exchange service on the same premises arranged for unrestricted use of the telecommunications network.
2. Long Distance Message Restriction will be provided to communications Systems from central offices which are equipped for such service. It is an arrangement whereby calls placed over trunks equipped with Long Distance Message Restriction are denied access to Long Distance Message Service.
3. The acceptance of long distance collect call messages is not restricted by this arrangement.

C. Rates

	Per Month	<u>USOC</u>
Long Distance Message Restriction		
Common Equipment, per group of lines controlled.....	\$30.74	LDE
Per Individual Exchange Service Line Arranged.....	.61	TD7
Common Equipment, per group of PBX trunks controlled.....	34.65	LDG
Per Individual PBX Trunk Arranged.....	7.60	TD7

Issued by authority of an Order of the Public Service Commission of West Virginia
in Case No. _____ dated _____.

GENERAL SERVICES TARIFF
P.S.C.-W.Va.-No. 203

Frontier West Virginia Inc.

Section 6
Original Page 8

Material pertaining to Fixed Call Forwarding has been transferred to Section 21 of this tariff.

Issued by authority of an Order of the Public Service Commission of West Virginia
in Case No. _____ dated _____.

Issued: January 8, 2001

Effective: January 8, 2001

SUPPLEMENTAL EQUIPMENT

Make-busy Arrangements

A. General

Make-busy Arrangements are provided to enable a customer, during certain periods, to make busy one or more incoming lines by the operation of a key at the customer's location.

B. Regulations

Make-busy Arrangements are provided only in connection with individual lines, PBX trunks, Toll Free Service access lines, and Centrex lines where the Centrex dial switching equipment is located on the Telephone Company's premises.

C. Rates

	<u>Per</u> <u>Month</u>	<u>USOC</u>
1. Make-busy Circuit, per line to be made busy.....	\$11.12	P89
2. Control Channel, per line to be made busy, each.....		(U)
Rates and charges apply as specified for Series 1000, type 1001, Channels in this Company's Channel Services Tariff, Section 2, between the customer's premises and the make-busy circuits located on the Telephone Company's premises.		

Issued by authority of an Order of the Public Service Commission of West Virginia in Case No. _____ dated _____.

SUPPLEMENTAL EQUIPMENT

Hunting Service Arrangements

A. General

A Hunting Service Arrangement is furnished using equipment located in the Telephone Company's central office arranged to select the next available line of a group of hunting lines, when the line associated with the called number in the hunting group is busy.

B. Regulations

1. Hunting Service Arrangements are offered only in connection with residence and business individual lines or PBX trunks.
2. All lines (includes PBX trunks) in a hunting group must originate from the same central office.
3. A single hunting group may be shared by two or more customers provided all the customers' lines are technically capable of being in the same hunting group.
4. Where two or more customers share the same hunting group, all lines in that hunting group must connect on the same premises.

C. Rates

	<u>Per</u> <u>Month</u>	<u>USOC</u>
Hunting Service Arrangement, per individual line or PBX trunk in a group so arranged.....	\$1.40	HTG

Issued by authority of an Order of the Public Service Commission of West Virginia in Case No. _____ dated _____.

SUPPLEMENTAL EQUIPMENT

Split Supervisory Drop Wire Arrangement

A. GENERAL

A Split Supervisory Drop Wire Arrangement provides for duplicate drop wire facilities from general distribution plant to the customer's premises. In the event one of the drop wires is cut, the arrangement allows for the activation of a local alarm, if provided by the customer, when used in connection with exchange service or Channel Service. Additionally, when used with Channel Service, the condition of one cut drop wire may be immediately transmitted to the distant end of the circuit, if provided for by the customer.

B. REGULATIONS

1. A Split Supervisory Drop Wire Arrangement can be furnished with a Channel Service or exchange service.
2. The drop wires will be placed a minimum of ten feet apart at the customers premises.

C. RATES

	<u>Installation</u> <u>Charge</u>	<u>Per</u> <u>Month</u>	<u>USOC</u>
Split Supervisory Drop Wire Arrangement, each.....	\$83.84	\$2.79	XL6

Issued by authority of an Order of the Public Service Commission of West Virginia in Case No. _____ dated _____.

SUPPLEMENTAL EQUIPMENT

Messaging Services Interface (MSI)/Premier Messaging Services Interface (PMSI)

A. General

Messaging Services Interface (MSI) is an arrangement which enables customer-provided equipment to automatically interact and connect with the customer's Local Exchange Service via a data link, on an intraoffice basis.

Premier Messaging Services Interface (PMSI) enables customer-provided equipment to automatically interact and connect with the customer's Local Exchange Service via the SS7 Network on an interoffice, as well as intraoffice, basis.

B. Regulations

1. Within the customer's serving central office, the Messaging Services Interface allows the customer to receive call type information via special multiline hunting group(s) and data link(s). The data link(s) connect in a customer-provided modem at the customer's premises. This modem must conform to the Electrical Industries Association standard RS232C interface requirements, operate in a full duplex, asynchronous mode, and use even parity error detection and standard ASCII code. Premier Messaging Services Interface allows the customer to receive call type information on an interoffice basis using the SS7 Network.
2. MSI and PMSI transmits the following information about a call that is directly dialed or forwarded to customer-provided equipment:
 - The called number,
 - The type of call forwarding or a direct call indication,
 - The calling number, and
 - The identification of the customer-provided equipment and multiline hunting group terminal numbers.
3. The Messaging Services Interface and Premier Messaging Services Interface provide a message waiting indicator which can be activated by the customer-provided equipment.
4. The customer has the responsibility for advising the Telephone Company of the quantity of lines in the multiline hunting group(s) based on anticipated traffic and call handling capabilities of the customer-provided premises equipment. The customer must contract for an adequate number of multi-line hunting group lines and related customer-provided premises equipment to permit the use of service without injurious effect on Local Exchange Service.

Issued by authority of an Order of the Public Service Commission of West Virginia in Case No. _____ dated _____.

GENERAL SERVICES TARIFF
P.S.C.-W.Va.-No. 203

Frontier West Virginia Inc.

Section 6
Original Page 12a

SUPPLEMENTAL EQUIPMENT

B. Regulations (Cont'd)

5. Customers subscribing to PMSI must subscribe to MSI from the central office switching system that serves their voice messaging equipment.
6. The integrity of the customer's database information is solely the responsibility of the customer. Frontier is not responsible for any errors, misdirected calls or misdirected message waiting indications that are a direct result of the customer database inaccuracies. Should Frontier be required to correct a condition on a subscriber's line that was caused by the customer's incorrect database information, time and material charges will be charged to the customer.
7. Premier Messaging Services Interface is available to Centrex customers who subscribe to Message Link Feature.

C. Rates

Messaging Service	<u>Installation Charge</u>	<u>Per Month</u>	<u>USOC</u>
Messaging Services Interface, per data link*.....	\$2400.00	\$200.00	SME
Premier Messaging Services Interface, each**	\$1000.00	\$450.00	SOE

* In addition, rates and charges apply for at least one Series 3000, type 3120, Channel for each Messaging Services Interface data link to the customer's modem from the Telephone Company's serving central office. The number of Series 3000 channels required is dependent upon the customer's configuration.

** Premier Messaging Services Interface requires MSI Service between the customer's equipment and one central office at a minimum.

NOTE:

Rates and charges apply for Local Exchange Service Lines and Centrex Lines in the multiline hunting group(s) and associated Hunting Service Arrangement(s) accessing the customer-provided equipment.

Issued by authority of an Order of the Public Service Commission of West Virginia
in Case No. _____ dated _____.

Issued: January 8, 2001

Effective: January 8, 2001

GENERAL SERVICES TARIFF
P.S.C.-W.Va.-No. 203

Frontier West Virginia Inc.

Section 6
Original Page 13

The material formerly found on this page for Automated Customer Trunk Testing Service is hereby cancelled and withdrawn.

Issued by authority of an Order of the Public Service Commission of West Virginia
in Case No. _____ dated _____.

Issued: January 8, 2001

Effective: January 8, 2001

GENERAL SERVICES TARIFF
P.S.C.-W.Va.-No. 203

Frontier West Virginia Inc.

Section 6
Original Page 14

SUPPLEMENTAL EQUIPMENT

Special Billing Numbers

A. General

Special Billing Numbers are provided in connection with services for Schools, Colleges and Universities to provide for billing of certain charges to students, faculty and employees who reside in dormitories or other living quarters owned, leased or under the control of the school.

B. Rates

	<u>Per</u> <u>Month</u>	<u>USOC</u>
Special Billing Number.....	\$.95	SBN

Issued by authority of an Order of the Public Service Commission of West Virginia in Case No. _____ dated _____.

Issued: January 8, 2001

Effective: January 8, 2001

GENERAL SERVICES TARIFF
P.S.C.-W.Va.-No. 203

Frontier West Virginia Inc.

Section 6
1st Revised Page 15
Cancels Original Page 15

SUPPLEMENTAL EQUIPMENT

Material formerly on this page has been cancelled and withdrawn.

Issued by authority of an Order of the Public Service Commission of West Virginia
in Case No. _____ dated _____.

Issued: June 19, 2001

Effective: July 20, 2001

GENERAL SERVICES TARIFF
P.S.C.-W.Va.-No. 203

Frontier West Virginia Inc.

Section 6
Original Page 16

SUPPLEMENTAL EQUIPMENT

The regulations and charge pertaining to Weatherproof Housings are hereby cancelled and withdrawn.

Issued by authority of an Order of the Public Service Commission of West Virginia
in Case No. _____ dated _____.

Issued: January 8, 2001

Effective: January 8, 2001

GENERAL SERVICES TARIFF
P.S.C.-W.Va.-No. 203

Frontier West Virginia Inc.

Section 6
Original Page 17

SUPPLEMENTAL EQUIPMENT

Transfer Arrangements (LA-3)

A. General

A central office Transfer Arrangement enables a customer to transfer incoming telephone calls to another bell or telephone.

B. Rates

	<u>Installation</u> <u>Charge</u>	<u>Per</u> <u>Month</u>	<u>USOC</u>
1. Transfer Arrangement			
Per line transferred.....	-	\$1.34	LTT

2. Control Channels

Rates and charges apply as specified for Series 1000, type 1001, Channels in this Company's Channel Services Tariff, Section 2, between the customer's premises and the Telephone Company central office.

Issued by authority of an Order of the Public Service Commission of West Virginia in Case No. _____ dated _____.

Issued: January 8, 2001

Effective: January 8, 2001

SUPPLEMENTAL EQUIPMENT

Central Office Data Sets

A. General

Central office data sets are for use with services that require a data set in the Telephone Company central office.

B. Regulations

Central office data sets will only be provided on a premises of the Telephone Company and may only be provided by the Telephone Company.

C. Rates

1. Data Set Model 100

Suitable for conditioning signals
at rates up to 300 bits per second
in sequence

	Installation Charge	Per Month	USOC
Combined sending and receiving set (108F and 108G), each*	\$ 72.66	\$23.48	DVS

2. Data Set Model 200

a. Suitable for conditioning signals
at a rate of 2400 bits per second
in sequence

Combined sending and receiving set (201C), each	167.69	72.66	24V
--	--------	-------	-----

b. Suitable for conditioning signals at rates
up to 1800 bits per second in sequence

Individually housed data set (202T)			
With reverse channel	72.66	45.83	18S
Without reverse channel	72.66	40.24	18L

Multiple mounted data set (202T),
requires appropriate common equip-
ment for multiple mounting, each

With reverse channel	55.90	40.24	1M9
Without reverse channel	55.90	34.65	1M8

* When a change in optional arrangements is requested by the customer subsequent to the initial installation, a change charge of \$70.43 will apply.

Issued by authority of an Order of the Public Service Commission of West Virginia in Case No. _____ dated _____.

GENERAL SERVICES TARIFF
P.S.C.-W.Va.-No. 203

Frontier West Virginia Inc.

Section 6
Original Page 18a

SUPPLEMENTAL EQUIPMENT

Central Office Data Sets (Cont'd)

C. Rates (Cont'd)

2. Data Set Model 200 (Cont'd)

	<u>Installation Charge</u>	<u>Per Month</u>	<u>USOC</u>
c. Suitable for conditioning signals at a rate of up to 1200 bits per second in sequence on the telecommunications network			
Originate and answer set (202S), equipped with expanded testing and status lamps			
(a) Individually housed data set			
With reverse channel.....	\$72.66	\$45.83	13G
Without reverse channel...	72.66	40.24	13B
(b) Individually housed data set (202S), for grouping of two to five sets, requires station arrangement			
With reverse channel.....	72.66	43.60	13C
Without reverse channel...	72.66	38.01	13L
(c) Multiple mounted data set, requires appropriate common equipment for multiple mounting, each			
With reverse channel.....	55.90	40.24	1M7
Without reverse channel...	55.90	34.65	1M4

Issued by authority of an Order of the Public Service Commission of West Virginia in Case No. _____ dated _____.

Issued: January 8, 2001

Effective: January 8, 2001

SUPPLEMENTAL EQUIPMENT

Central Office Data Sets (Cont'd)

C. Rates (Cont'd)

2. Data Set Model 200 (Cont'd)

- d. Suitable for conditioning signals at rates of one to 300 bits per second or 1200 bits per second in sequence, for use on telecommunications network only.

Originate and answer set (212A), equipped with expanded testing and status lamps

(1) Payment Plan 1 (LA-2)	<u>Installation Charge</u>	<u>Per Month</u>		<u>USOC</u>
		A*	B*	
Individually housed data set, each				D2A
12-Month Option.....	\$72.66	\$115.8	\$6.60	
		0		
24-Month Option.....	72.66	61.15	6.60	
36-Month Option.....	72.66	43.00	6.60	
 (2) Payment Plan 2				
		<u>Installation Charge</u>	<u>Per Month</u>	
Individually housed data set, each.....		\$72.66	\$44.72	D2A
Individually housed data set for grouping two to five sets, requires station arrangement, each.....		72.66	41.36	D2B
Multiple mounted data set, requires appropriate common equipment for multiple mounting, each.....		55.90	35.21	D2C

* These rates are applicable only to existing payment plans for associated systems. Equipment additions to existing systems will only be furnished at rates and charges as specified under Payment Plan 2.

Issued by authority of an Order of the Public Service Commission of West Virginia in Case No. _____ dated _____.

SUPPLEMENTAL EQUIPMENT

700/900 Call Restriction Service

A. General

The 700/900 Call Restriction Service is an arrangement which prohibits one plus direct-dialed access and 0+ access to 700 and 900 service telephone numbers from selected Local Exchange Service lines.

B. Regulations

1. The 700/900 Call Restriction Service is provided only on Local Exchange Service individual lines served by electronic switching equipment capable of providing this option.
2. Customers may elect to restrict calls to 700 service telephone numbers only, 900 service telephone numbers only, or both 700 and 900 service telephone numbers.

C. Rates

700/900 Call Restriction Service, per line arranged

	<u>Per</u> <u>Month</u>	<u>USOC</u>
700 Restriction, 900 Restriction or 700 and 900 Restriction.....	None*	(U)

* No Service Charge applies when installed coincident with the establishment of the associated individual line.

Issued by authority of an Order of the Public Service Commission of West Virginia in Case No. _____ dated _____.

SUPPLEMENTAL EQUIPMENT

Uniform Call Distribution Service

A. General

Uniform Call Distribution Service provides for the uniform distribution of incoming calls, in order of their arrival, to specified telephone lines.

B. Regulations

Uniform Call Distribution Service is offered for use with all types of telephone lines excluding lines of Centrex services, provided such telephone lines are arranged in a common multiline hunting group and served from compatible electronic type switching equipment.

C. Rates

	<u>Installation Charge</u>	<u>Per Month</u>	<u>USOC</u>
1. Per hunting group.....	\$460.00	None	AHBPG
2. Per line in the hunting group.....	16.00	\$.20	AHB

Issued by authority of an Order of the Public Service Commission of West Virginia in Case No. _____ dated _____.

SUPPLEMENTAL EQUIPMENT

Call Restriction Service

A. General

Call Restriction Service is an arrangement which permits an individual line and PBX Trunk to dial local service area calls but prevents the origination of long distance type calls.

B. Regulations

1. Call Restriction Service is provided only on Local Exchange Service individual lines and PBX Trunks.
2. Call Restriction Service allows access to the operator to complete credit card, third party billing and collect calls. The charges for operator completed (0-) or operator serviced (0+) calls is as specified in the Long Distance Services Tariff, Special Service Charges, as appropriate.
3. The acceptance of incoming traffic and billing arrangements are not restricted by this arrangement.
4. Call Restriction Service allows calling to Directory Assistance, Toll Free Services and local Telephone Company Business offices.

C. Rates

	<u>Per</u> <u>Month</u>	<u>USOC</u>
Call Restriction Service, per line arranged.....	\$1.00	DHL

Issued by authority of an Order of the Public Service Commission of West Virginia
in Case No. _____ dated _____.

SUPPLEMENTAL EQUIPMENT

Ring Count Change Interface

A. GENERAL

Ring Count Change Interface is an optional service which facilitates the use of Call Forwarding-Don't Answer by allowing a subscriber to electronically request a change in the number of rings which occur before calls are forwarded by Call Forwarding-Don't Answer. Subscribers for Ring Count Change Interface may include, but are not limited to, voice messaging service providers and other enhanced service providers who provide facilities which permit their customers who subscribe to Call Forwarding-Don't Answer to request, through Ring Count Change Interface, changes in the number of rings which occur before calls are forwarded by the customers' Call Forwarding-Don't Answer service.

B. REGULATIONS

1. The customer must connect to the Telephone Company service platform via an appropriately equipped private data line.
2. The customer's service interface must conform to the Telephone Company's Ring Count Change Interface protocol specification.
3. The customer is responsible for the security and integrity of the requests sent to the Telephone Company's service platform.
4. Due to technical limitations, Ring Count Change Interface cannot be used to implement ring count changes for Call Forwarding-Don't Answer customers with Centrex Services or MVP or RSVP services, or for some Call Forwarding-Don't Answer customers with multi-line hunt groups.
5. Ring Count Change Interface is available where facilities permit.

C. RATES

	<u>Installation Charge</u>	<u>Per Month</u>
Per Data Link.....	\$1,000.00	\$650.0 0

Issued by authority of an Order of the Public Service Commission of West Virginia
in Case No. _____ dated _____.

SUPPLEMENTAL EQUIPMENT

Three-way Call Transfer

A. GENERAL

Three-way Call Transfer is an optional service which permits Enhanced Service Providers (ESPs) utilizing interoffice trunk facilities to offer a variety of voice mail services to their subscribers.

B. REGULATIONS

1. Three-way Call Transfer is a service which provides the capability of transferring an established call to another party and freeing the line to initiate or receive other calls; or adding a third party to a call in progress and dropping off the call without disconnecting the remaining callers.
2. Three-way Call Transfer is available to Enhanced Service Providers utilizing trunk facilities served from digital central offices only. Three-way Call Transfer is not available to residence, pay telephone, Toll Free, WATS or Centrex subscribers. This service is provided, as facilities permit, as determined by Verizon.
3. Any Enhanced Service Provider equipment required as part of this service must be provided by the Enhanced Service Provider at its expense and must be compatible with and meet the interface specifications of Verizon.
4. The Enhanced Service Provider is responsible for subscribing to an adequate number of trunks and related equipment that will permit the use of this service without interfering with general telephone service.
5. It will be the responsibility of the Enhanced Service Provider to inform its subscribers of the use and operation of its services.

C. RATES

	<u>Installation</u> <u>Charge</u>	<u>Per</u> <u>Month</u>	<u>USOC</u>
1. Three-way Call Transfer, per trunk	\$ 25.00	\$5.00	EO3

In addition, the Enhanced Service Provider will be billed the appropriate local and toll usage charges, as specified in this Company's Local Exchange Services Tariff and Long Distance Services Tariff, respectively, associated with the use of this service.

Issued by authority of an Order of the Public Service Commission of West Virginia in Case No. _____ dated _____.

GENERAL SERVICES TARIFF
P.S.C.-W.Va.-No. 203

Frontier West Virginia Inc.

Section 7
1st Revised Page 1
Cancels Original Page 1

CONVENIENCE FEE

(N)

A. GENERAL

A convenience fee is a charge that is added onto a customer's account if a customer makes a payment using a Company Representative. The customer is informed by the Company Representative of the applicable charges prior to processing the payment. The charge will be collected at time of payment processing.

B. REGULATIONS

This fee will not apply if:

- The automated payment systems are unavailable due to system outages.
- At the time payment is made, the customer agrees to sign up for automatic bill payment.
- Payment is taken for a deposit.
- The payment is for a Government account.

C. RATES

Nonrecurring Charge

Convenience Fee, per occurrence

\$4.50

(N)

Issued by authority of an Order of the Public Service Commission of West Virginia in Case No. 17-0659-T-T dated June 14, 2017.

Issued: May 19, 2017

Effective: June 18, 2017

PREFERRED TELEPHONE NUMBER SERVICE

A. GENERAL

Preferred Telephone Number Service provides for the assignment of a telephone number (last four digits) which is selected by the customer, rather than the telephone number normally assigned by the Telephone Company.

B. REGULATIONS

1. Preferred Telephone Number Service is offered in connection with Local Exchange Services.
2. Preferred Telephone Number Service may be established only in association with the initial establishment of a service, the relocation of an existing service, or a customer-requested change in an existing telephone number, in which case any unpaid balance must be paid prior to obtaining the preferred telephone number.
3. The provision of a preferred telephone number is based upon the current availability of that telephone number. No alphanumeric Directory Listing offered with this service.
4. In connection with Centrex Service and branch exchange services, Preferred Telephone Number Service is offered only on the telephone number associated with the primary Directory Listing for such services.
5. The offering of Preferred Telephone Number Service is conditioned upon the requested number agreeing with the telephone industry standard for Tone Signaling and shall not be considered offensive by the Telephone Company.
6. The Telephone Company will not change an existing telephone number for the purpose of making that number available to a Preferred Telephone Number Service request without the prior consent and approval of the customer to whom that number is currently assigned.
7. Preferred Telephone Number Service charges shall not apply to a request by a customer for the reassignment of his previous telephone number, if available, upon the reconnection of previously terminated service. The Preferred Telephone Number Service charge is also not applicable to the relocation of an existing working telephone number.

Issued by authority of an Order of the Public Service Commission of West Virginia
in Case No. _____ Dated _____.

GENERAL SERVICES TARIFF
P.S.C.-W.Va.-No. 203

Frontier West Virginia Inc.

Section 8
Original Page 2

PREFERRED TELEPHONE NUMBER SERVICE

C. RATES

For Preferred Telephone Numbers Associated with:

	<u>Establishment Charge</u>	<u>Per Month</u>	<u>USOC</u>
1. Residence Services, per preferred telephone number.....	\$ 5.00	-	RNCSP
2. Business Services, per preferred telephone number.....	-	-	RNCSP

Issued by authority of an Order of the Public Service Commission of West Virginia
in Case No. _____ Dated _____.

Issued: January 8, 2001

Effective: January 8, 2001

DIRECTORY ASSISTANCE SERVICE

A. GENERAL

The Telephone Company furnishes Directory Assistance Service whereby customers may request assistance in determining telephone numbers.

B. REGULATIONS

1. The rates set forth following apply when customers request Telephone Company assistance in determining telephone numbers of customers who are located in the same local service area or who are not located in the same local service area but who are located within the State of West Virginia.
2. A residence customer is allowed two Directory Assistance Service calls per dial tone line, a Centrex Dormitory Service line, or a special identification number for students associated with Centrex Dormitory Service per month or fraction thereof, at no Directory Assistance Service charge.
3. For calls placed through a Telephone Company Operator, an Operator Assisted Local Call charge as specified in Section 20 of this Tariff applies in addition to the charge for Directory Assistance Service calls specified in C. following, except the Operator Assisted Local Call charge will not apply in the following cases:
 - a. To reach the called Directory Assistance Service number where direct dialing facilities are not available.
 - b. To reach the called Directory Assistance Service number when attempts by the customer to direct dial such a call cannot be completed.
 - c. To only record the originating telephone number where no automatic recording equipment is available.
 - d. To only record the special identification number of a student for a call placed from a Centrex Dormitory Service station.
4. Call allowances are not transferable between separate accounts of the same customer.
5. Charges for Directory Assistance Service are not applicable to calls to the Directory Assistance Service attendant from telephones where the customer, and in the case of residence service where the customer or a member of the customer's household, has been affirmed in writing as unable to use a Telephone Company provided directory because of a visual or physical handicap.

Issued by authority of an Order of the Public Service Commission of West Virginia
in Case No. _____ Dated _____.

GENERAL SERVICES TARIFF
P.S.C.-W.Va.-No. 203

Frontier West Virginia Inc.

Section 9
4th Revised Page 2
Cancels 3rd Revised Page 2

DIRECTORY ASSISTANCE SERVICE

B. REGULATIONS (Cont'd)

6. The customer may request a search by type of business, or "Business Category Search," when the name of the business is not known. Customers will be charged for each heading or category requested, (up to a maximum of 2 headings on a call) whether or not listings are found or are non-published. Up to three numbers randomly selected may be provided per heading searched. Local Directory Assistance call allowances apply to Business Category Search calls.

(N)
|
(N)

C. RATES

Directory Assistance Service Calls*, per call..... \$.75

* Maximum of two requested telephone numbers per call; no discounts will be allowed on charges for Directory Assistance Service.

Issued by authority of an Order of the Public Service Commission of West Virginia in Case No. _____ Dated _____.

GENERAL SERVICES TARIFF
P.S.C.-W.Va.-No. 203

Frontier West Virginia Inc.

Section 9A
1st Revised Page 1
Cancels Original Page 1

(RESERVED FOR FUTURE USE)

(C)
(O)

Issued by authority of an Order of the Public Service Commission of West Virginia in
Case No. 11-0799-T-T dated June 21, 2011.

Issued: June 2, 2011

Effective: July 2, 2011

GENERAL SERVICES TARIFF
P.S.C.-W.Va.-No. 203

Frontier West Virginia Inc.

Section 9B
Original Page 1

NATIONAL DIRECTORY ASSISTANCE SERVICE

A. GENERAL

National Directory Assistance (NDA) Service provides customers the listings of individuals or businesses located outside the State of West Virginia, but within the United States. Requests for listings that are within the state are provided and billed as specified in Section 9 of this Tariff.

B. REGULATIONS

1. NDA Service is subject to the availability of facilities.
2. The rate specified in C. following will apply for all NDA requests, including requests for listings that are non-published, non-listed or not found.
3. A maximum of two requests for listings will be allowed per call; no discounts will apply on charges for NDA Service.
4. No call allowances apply to NDA Service.
5. Charges for NDA Service are not applicable to calls from telephones where the customer and, in the case of residence service, where the customer or a member of the customer's household has been affirmed as being unable to use a directory because of a visual or physical disability, pursuant to Section 9.B.5 of this Tariff.
6. Frontier West Virginia shall not be liable for any errors or omissions, whether arising through negligence or otherwise, in the information furnished, and the customer shall save Frontier West Virginia harmless against all claims that may arise from the use of such information.
7. Alternate billing arrangements are not permitted for NDA Service.

Issued by authority of an Order of the Public Service Commission of West Virginia
in Case No. _____ Dated _____.

GENERAL SERVICES TARIFF
P.S.C.-W.Va.-No. 203

Frontier West Virginia Inc.

Section 9B
2nd Revised Page 2
Cancels 1st Revised Page 2

NATIONAL DIRECTORY ASSISTANCE SERVICE

8. If a customer requests both an NDA and a West Virginia listing on the same call, the customer will be charged only the rate for an NDA listing, as specified in C. following.

9. NDA will not be offered from the following services:

Dormitory Centrex
Hospital Patient Lines
Hotel/Motel Guest Lines

(O)
(O)

Mobile Type 1 Service

C. RATES

National Directory Assistance Service, per call Rate Deregulated

* For calls placed through a "0" Frontier operator, an Operator-assisted Local Call charge, as specified in Section 20 of this Tariff, applies in addition to the charge for NDA Service calls.

Issued by authority of an Order of the Public Service Commission of West Virginia in
Case No. _____ Dated _____.

Issued: April 7, 2003

Effective: April 7, 2003

GENERAL SERVICES TARIFF
P.S.C.-W.Va.-No. 203

Frontier West Virginia Inc.

Section 9C
1st Revised Page 1
Cancels Original Page 1

SERVICE REQUEST SERVICE

(C)

A. GENERAL

Service Request Service provides Directory Assistance customers calling from Touch-Tone telephones the ability to have the requested number automatically dialed by the Operator Services System (OSS).

(C)

B. REGULATIONS

1. Explanation of Terms

Service Request Blocking Option

(C)

Service Request blocking option prevents the effected line(s) from accessing Service Request Service.

(C)

(C)

2. The Service Request service surcharge is applied only to completed calls.

(C)

3. Service Request Service calls automatically completed are subject to the Service Request Service charge and any other applicable rates for the call.

(C)

(C)

4. Charges for this service are not applicable to calls placed by persons who affirm in writing to the Telephone Company that a visual or physical handicap prevents them from using the telephone directory. This exception is limited to Service Request Service calls placed from a handicapped person's household or a business telephone used exclusively by a handicapped person.

(C)

5. This service will not be offered on Directory Assistance calls placed from the following services or by the following customers:

Services

Service for Customer-provided Coin and Credit Card Telephones
Long Distance Message Restriction
Pay Telephone Network Lines
Call Restriction Service

Customers

Cellular
Charge-a-Call
Dormitory Centrex
Hospital Patient Lines
Hotel/Motel Guest Lines

Issued by authority of an Order of the Public Service Commission of West Virginia in Case No. 11-0799-T-T dated June 21, 2011.

GENERAL SERVICES TARIFF
P.S.C.-W.Va.-No. 203

Frontier West Virginia Inc.

Section 9C
3rd Revised Page 2
Cancels 2nd Revised Page 2

SERVICE REQUEST SERVICE (C)

B. REGULATIONS (Cont'd)

- 6. Requests for call completion to 700, Toll Free and 900, Toll Free telephone numbers will not be offered.
- 7. Service Request Service will be offered on only the last of the two (2) numbers available for each request to Directory Assistance. (C)
- 8. An Optional Calling Plan customer who places a Service Request call will be billed Optional Calling Plan rates for the call. (C)

C. RATES

Service Request Service, per call completed..... \$.50 (C)

Issued by authority of an Order of the Public Service Commission of West Virginia in Case No. 11-0799-T-T dated June 21, 2011.

Frontier West Virginia Inc.

Section 9D
1st Revised Page 1
Cancels Original Page 1

REFERRAL SERVICES

A. GENERAL

Referral Services announce to the calling party the status of a called party's number and, when appropriate, refer the calling party to a number(s) where the called party can be reached for a specified time period.

Basic Referral Service uses a recorded announcement to give the caller of a disconnected, suspended or changed number, the number's status that may include a referral number.

Extended Basic Referral Service* provides a recorded announcement that states the line number status and a referral number for calls placed to a disconnected or changed residence or business line number.

(N)

B. REGULATIONS

1. Referral Services are subject to the availability of facilities.

2. Basic Referral Service

a. This service is provided to customers without additional charge.

b. This service is normally available for a maximum of 30 days.

c.

(D)

(D)

3. Extended Basic Referral Service*

(N)

a. This service provides an extended referral to residence and business customers beyond the basic referral period.

b. This service can be provisioned to refer disconnected lines to the same number or each disconnected line can be referred to a different number.

c. For residence line numbers, the minimum period for this service is one month and the maximum period is ten months. For business line numbers, the minimum period for this service is one month and the maximum period is three months.

4. Centrex, PBX and DID auxiliary lines are excluded from a free referral period.

*This service is limited to existing customers at their existing location.

(N)

Issued by authority of an Order of the Public Service Commission of West Virginia in Case No. _____ dated _____.

GENERAL SERVICES TARIFF
P.S.C.-W.Va.-No. 203

Frontier West Virginia Inc.

Section 9D
1st Revised Page 2
Cancels Original Page 2

REFERRAL SERVICES

C. RATES

1. The charge for a Referral Service is billed in advance as a one-time charge on the final bill for that number.

(D)

2.

(D)

	<u>Per Month</u>
3. Basic Referral Service	
Residence	-
Business	-
4. Extended Basic Referral Service*	
Residence	\$10.00
Business	10.00

(N)

*This service is limited to existing customers at their existing location.

(N)

Issued by authority of an Order of the Public Service Commission of West Virginia
in Case No. _____ Dated _____.

GENERAL SERVICES TARIFF
P.S.C.-W.Va.-No. 203

Frontier West Virginia Inc.

Section 9E
3rd Revised Page 1
Cancels 2nd Revised Page 1

(RESERVED FOR FUTURE USE)

(C)

Issued by authority of an Order of the Public Service Commission of West Virginia
in Case No. 11-0799-T-T dated June 21, 2011.

Issued: June 2, 2011

Effective: July 2, 2011

GENERAL SERVICES TARIFF
P.S.C.-W.Va.-No. 203

Frontier West Virginia Inc.

Section 9F
1st Revised Page 1
Cancels Original Page 1

CALL DIRECT AND MESSAGE SERVICE

(C)

A. GENERAL

Call Direct and Message Service (CDMS) provides intercept arrangements that offer recorded announcements and/or transfer of calls for a time period specified by customers when they permanently disconnect, temporarily suspend, or change their line numbers.

(C)

B. REGULATIONS

Explanation of Terms

Call Direct

Call Direct provides to the caller of a disconnected, temporarily suspended, or changed line number an automatic call transfer to the referral number, without an announcement of the referral number.

Call Direct Plus

Call Direct Plus uses a recorded announcement to give the caller of a disconnected, temporarily suspended, or changed line number, the number's status and the referral number before transferring the call to the referral number.

Call Messenger

Call Messenger uses a recorded announcement to give the caller of a disconnected, temporarily suspended, or changed line number, the number's status, the customer's name, the customer's new address, and the referral number.

Call Messenger Plus

Call Messenger Plus uses a recorded announcement to give the caller of a disconnected, temporarily suspended, or changed line number, a Call Messenger announcement before transferring the call to the referral number.

2. The services in this Tariff are provided to customers where facilities are available. Frontier may offer Call Direct in lieu of basic referral service to customers who use TTY/TDD machines.
3. Call Direct and Message Service options are available in combination with basic referral service and are provided in consecutive months of service. Customers are restricted to a combination Call Direct and Message Service and basic referral service not to exceed 12 months' maximum service of which Call Direct and Message Service may be a minimum of one month.

Issued by authority of an Order of the Public Service Commission of West Virginia in Case No. 11-0799-T-T dated June 21, 2011.

Issued: June 2, 2011

Effective: July 2, 2011

GENERAL SERVICES TARIFF
P.S.C.-W.Va.-No. 203

Frontier West Virginia Inc.

Section 9F
1st Revised Page 2
Cancels Original Page 2

CALL DIRECT AND MESSAGE SERVICE

(C)

B. REGULATIONS (Cont'd)

4. Both the intercepted and referral telephone numbers must be within the same Local Access Transport Area (LATA) and calls transported exclusively on the Telephone Company's facilities for all Call Direct and Message Service options, except Call Messenger. (C)
5. Customers may designate only one telephone number for use as the referral number.
6. The services described in this Tariff are not available to 556, 700, 900, and 976 customers. Toll Free number customers may only purchase the Call Messenger service option.
7. Customers who permanently disconnect their line number(s) and terminate their account must acquire third-party (customer who will receive the referred calls) consent and acceptance of usage charges prior to purchasing Call Direct and Message Service. (C)
8. Call Direct and Message Service will not be provided or continued when either the service of the customer who requests Call Direct and Message Service or the third party's service is suspended or disconnected. The same restriction applies to those customers whose service is toll-denied, except for residence customers when the distance between the intercepted and referral number locations is classified as a local call. (C)
9. For Centrex and DID customers, the number of messages available per system may be determined as facilities permit. (C)

C. RATES

1. Application of Rates
 - a. The charge for this service is based on the duration of service requested per line number and will appear on the customer's final bill for that number. Usage charges, either local or toll, resulting from the transfer of calls will appear on the monthly bill relating to the referral number and will be payable by the consenting third party. Originating calls that are forwarded to the intercepted number will be billed the appropriate message usage charge. Toll charges, if applicable, will apply.
 - b. Customer requests for termination of this service prior to the agreed upon termination date will be honored, and credit/reimbursement arrangements are available for the unused portion of service. However, customers are responsible for one-month minimum charge and the monthly charge for each full or partial subsequent month that service was provided. Billing is based on an entire month of service; partial month adjustments are not available.

Issued by authority of an Order of the Public Service Commission of West Virginia in Case No. 11-0799-T-T dated June 21, 2011.

Issued: June 2, 2011

Effective: July 2, 2011

GENERAL SERVICES TARIFF
P.S.C.-W.Va.-No. 203

Frontier West Virginia Inc.

Section 9F
2nd Revised Page 3
Cancels 1st Revised Page 3

CALL DIRECT AND MESSAGE SERVICE

(C)

C. RATES (Cont'd)	<u>Per Month</u> Line Number	<u>Charge*</u>	<u>USOC</u>
2. Rates and Charges			
Call Direct			
Residence, per Line Number		\$ 9.00	C18
Business, per Line Number		15.00	C18
Call Direct Plus			
Residence, per Line Number		\$9.90	C191X
Business, per Line Number		16.00	C191X
Call Messenger			
Residence, per Line Number		15.00	PMA
Business, per Line Number		18.00	PMA
Call Messenger Plus			
Residence, per Line Number		\$21.00	C192X
Business, per Line Number		25.00	C192X

* The line number charge is applied to each line number for the length of service requested and paid in advance. For example, if a customer requests a Call Direct and Message Service for three months, the Line Number charge would be multiplied by three. (C)
(C)

Issued by authority of an Order of the Public Service Commission of West Virginia in Case No. 11-0799-T-T dated June 21, 2011.

Issued: June 2, 2011 Effective: July 2, 2011

GENERAL SERVICES TARIFF
P.S.C.-W.Va.-No. 203

Frontier West Virginia Inc.

Section 10
3rd Revised Page 1
Cancels 2nd Revised Page 1

SUSPENSION OF SERVICE - Grandfathered ¹

(C)

A. GENERAL

Exchange telephone service may be temporarily suspended, at the customer's request, without termination of contract, subject to conditions specified herein.

B. REGULATIONS

1. Exchange telephone service may be suspended as follows.

a. Entire Service

A customer for any class of business or residence exchange telephone service, excluding the following, may suspend the entire service.

Electronic Concentrator for AUTOTAS* Answering Systems

b. Portion of Service

A customer for business or residence individual line, branch exchange or Centrex Service, excluding the following, may suspend a portion of the service.

Electronic Concentrator for AUTOTAS Answering Systems

In connection with individual line service, each line with all of its connections and supplemental services may be suspended. In connection with Centrex Service, attendant positions, station lines and associated connections, supplemental equipment may be suspended without suspension of the entire service.

2. The following minimum and maximum suspension periods for exchange service are the time periods during which the rates specified in C. following apply.

a. The minimum period of suspension shall not be less than one month.

b. Temporary Suspension is available to a customer for a maximum period of nine (9) months. The customer's number must be working for at least 90 days in a calendar year.

* Registered Trademark of Candela Electronics Corp.

¹ Suspension of Service is limited to all existing customers at their existing locations as of June 4, 2022.

(N)
(N)

Issued by authority of an Order of the Public Service Commission of West Virginia in Case No. 22-0428-T-T dated May 9, 2022.

Issued: May 4, 2022

Effective: June 4, 2022

GENERAL SERVICES TARIFF
P.S.C.-W.Va.-No. 203

Frontier West Virginia Inc.

Section 10
1st Revised Page 2
Cancels Original Page 2

SUSPENSION OF SERVICE - Grandfathered ¹

(C)

B. REGULATIONS (Cont'd)

- 3. For Centrex Service, the suspended service rate must equal or exceed the continuing minimum monthly charge. For Centrex Dormitory Service, suspension of service regulations apply for each dormitory room or residential quarters.
- 4. When the initial contract period applicable to the service being suspended is in excess of one month, suspension of service prior to the expiration of the contract period does not extend the contract period.
- 5. No inward or outward service is contemplated during the period of suspension at the rates specified in C. following.

C. RATES

The following rates apply during the period of suspension, except as specified for Centrex Service in B.3. preceding.

Exchange Telephone Service

	<u>Per Month</u>
1. Suspension of Entire Service.....	50% of the fixed monthly charge.
2. Suspension of a Portion of Service.....	50% of the fixed monthly charge for the service suspended.

¹ Suspension of Service is limited to all existing customers at their existing locations as of June 4, 2022.

(N)
(N)

Issued by authority of an Order of the Public Service Commission of West Virginia in Case No. 22-0428-T-T dated May 9, 2022.

Issued: May 4, 2022

Effective: June 4, 2022

GENERAL SERVICES TARIFF
P.S.C.-W.Va.-No. 203

Frontier West Virginia Inc.

Section 11
1st Revised Page 1
Cancels Original Page 1

SWITCHED 56-KILOBIT SERVICE

A. GENERAL

Switched 56-kilobit Service provides a customer with the ability to send and receive data at a speed of 56,000 bits per second over the telecommunications network.

B. REGULATIONS

1. Explanation of Terms

Local Line

A local line provides a communications path between a customer's premises and the serving Switched 56-kilobit Service wire center for customers who are located within the normal serving area of an equipped Switched 56-kilobit Service wire center.

Remote Line

A remote line provides a communications path between a customer's premises, through the customer's normal serving wire center, and the serving Switched 56-kilobit Service wire center for customers who are not located within the normal serving area of an equipped Switched 56-kilobit Service wire center.

Minutes of Use (MOU)

Minutes of Use are applied for the duration of an Originator's call, on a per-call basis. (C)
(T)

Mileage

Mileage is the airline distance between the Local serving office and the Switched 56 equipped serving office.

2. Switched 56-kilobit Service is business service, and is provided only from specially equipped Telephone Company central offices located in designated wire centers in conjunction with network facilities designed to accommodate only 56 kilobits per second, full duplex, synchronous transmission.
3. Switched 56-kilobit Service is provided, subject to the availability of appropriate network facilities, from the closest designated Switched 56-kilobit Service wire center.

Issued by authority of an Order of the Public Service Commission of West Virginia in Case No. _____ dated _____.

GENERAL SERVICES TARIFF
P.S.C.-W.Va.-No. 203

Frontier West Virginia Inc.

Section 11
Original Page 2

SWITCHED 56-KILOBIT SERVICE

C. RATES

1. Application of Rates

- a. All originating calls from a Switched 56-kilobit Service will be charged for on a minutes-of-use basis. Such charges are in addition to all other applicable local or long distance charges, as appropriate.
- b. A remote line is subject to a monthly per-mile rate from the Switched 56-kilobit Service wire center to the customer's normal serving wire center. Mileage is measured airline distance between the two wire centers.

2. Switched 56-kilobit Service

	<u>Installation Charge</u>	<u>Per Month</u>	<u>USOC</u>
a. Local and Remote Lines, each.....	\$725.00	\$150.00	SD6 S56
b. Mileage, each remote line, per mile.....		1.00	1LXMS
		<u>Per Minute of Use</u>	
c. Originating Calls, each.....		\$.14	-

Issued by authority of an Order of the Public Service Commission of West Virginia in Case No. _____ dated _____.

Issued: January 8, 2001

Effective: January 8, 2001

CUSTOM REDIRECT SERVICE

A. GENERAL

Custom Redirect Service (CRS) is a service that, when activated by the customer, will redirect all or part of the customer's incoming switched voice and data calls to another location(s) of the customer's choice. The redirection can occur on a permanent basis, automatically according to predetermined parameters, and/or upon command by the customer. This service may be used in the event of a communications failure, cable cut, fire, flood, or any other event requiring calls to be handled from alternate telephone numbers or an alternate location.

Basic Custom Redirect Service offers three options to redirect calls to as many (C) as three telephone numbers. It is assumed that the first option will be a basic redirect to the dialed number, but that is not a requirement. If the dialed number is not part of one of the options, then calls will always be redirected away from the dialed number. The customer may designate that the basic redirection feature be used in each of the options, or the customer may select a Custom Redirect Optional Feature as described in B2.

B. REGULATIONS

1. Explanation of Terms

Equipped Number

Equipped Number is the subscriber's called telephone number that has Custom Redirect Service.

Group

A group is the collection of Equipped Numbers that will be redirected in the same way, at the same time. For example, if redirection is requested, all telephone numbers within that group will be redirected. Another example is, if the customer chooses to have option three "active" in a particular group, and then all equipped numbers in the group will be redirected according to the direction in option three.

Every group must have the same optional features in each of the options. For example, if the option column has time of day redirection, then the times that the numbers are redirected are the same for all the numbers in that group. The actual telephone numbers that the calls are being redirected to do not have to be the same. For all optional features, the telephone number that the calls are redirected to may be different.

Issued by authority of an Order of the Public Service Commission of West Virginia in Case No. _____ dated _____.

CUSTOM REDIRECT SERVICE

B. REGULATIONS (Cont'd)

1. Explanation of Terms (Cont'd)

Option Column

An Option Column is a column of telephone numbers that are treated the same. Custom Redirect Service has three option columns per group with the basic service. If more than three options are chosen the Additional Option charge applies per additional option chosen. Up to 6 additional options may be provisioned as an enhancement. Only one option is active for a group at any given time. For example, in a particular group the first option may be the original dialed number, the second option may be the home telephone number, and the third option might be a telephone number in an affiliate office in another city. If option two were selected, all telephone numbers in this group would be redirected to the respective telephone number in option column two. Similarly, if the customer selected option column three to be in effect and option three was provisioned with a Custom Redirect Service optional feature then all telephone numbers in this option column would have the optional feature. (C) (C)

Redirecting Telephone Number

A Redirecting Telephone Number will have no office equipment associated with it and will be used solely for the purpose of redirecting call traffic from the telephone number dialed to the Custom Redirect Service customer's intended destination.

Modification of Active Option

When the customer elects to redirect calls, the customer calls into the Telephone Company platform using a touch-tone telephone. Upon reaching the platform, the customer must pass through a series of security blocks to get into the system. Calls may also be redirected by calling a live attendant, who, after verifying security information, will establish the redirection of the calls.

After authorization is confirmed, the customer specifies which group and which option is to be activated. A group may be a floor, department, building, or some other customer-defined list of numbers. These groups are pre-assigned upon the establishment of the service.

The customer may call in to have the active option modified as frequently as desired. When calls are terminated to any number other than the originally dialed number redirection charges will apply.

CUSTOM REDIRECT SERVICE

B. REGULATIONS (Cont'd)

1. Explanation of Terms (Cont'd)

Optional Features

Alternate Central Office Triggering

Alternate Central Office Triggering allows customers to redirect from the office in which the call originates without requiring the call to complete to the terminating central office. In the event that the terminating central office is out of service, the customer's Custom Redirect Service may be activated and all calls processing in an office with an alternate office trigger will be redirected per the current active option at that time.

The ability to place triggers in central office switches versus the terminating central office, may increase the call volumes processed. The customer's Group charges would be reflective of this increased call volume. Triggers are associated with a specific customer NPA-NNX.

(C)

(N)

Auto-attendant Redirecting

As an optional feature, the Telephone Company will load a customer-defined, Company-approved pre-recorded message. After incoming callers hear the message, they may be disconnected, or transferred without requiring a response, or the caller may be prompted to enter a "1", "2" or "3" on their touch-tone pad. The call will then be redirected to a telephone number that the customer designated for that selection. The customer may select up to three redirect choices for each main number. The Auto-Attendant Redirecting feature may be used with any of the option columns. If this feature were used in more than one option, the optional feature charge would apply to each option utilizing the feature.

Frontier West Virginia Inc.

Section 12
3rd Revised Page 3
Cancels 2nd Revised Page 3

CUSTOM REDIRECT SERVICE

B. REGULATIONS (Cont'd)

1. Explanation of Terms (Cont'd)

Optional Features (Cont'd)

Custom Applications

Although most customer applications are provided using the optional features listed above, custom applications may also be provisioned. Custom applications will include the inclusion of a single table or field manipulation in the call processing record to meet a specific customer's need. Next Event List (NEL) and Dialed Number Recovery (DNR) are examples of Custom Applications. (N)

Next Event List (NEL) is a Custom Application that provides redirection of numbers conditional upon network status, i.e., complete this number as dialed unless the following condition is encountered. NEL triggers are placed in the terminating office. NEL is not used to monitor Central Office outages, it is used to monitor for PRI outages and does not monitor for station busy or no answer.

Dialed Number Recovery (DNR) is a Custom Application where the original dialed number is presented to a new customer location. (N)

Very complex applications, and applications for purposes other than the directing of incoming calls will not be considered part of this feature and will require special assemblies.

Number Identification Redirecting

Number Identification Redirecting allows the customer to redirect calls based upon the originating telephone number, NXX, LATA, or NPA of the incoming caller. This will allow the customer to direct particular callers to specific numbers based upon their telephone number. If an incoming caller's number is on the list, the call will be redirected to the "on-list" number. If the incoming caller's telephone number is not on the list, the call will be completed as dialed.

Material formerly found on this page now appears on 1st Revised Page 3a. (N)

Issued by authority of an Order of the Public Service Commission of West Virginia in Case No. _____ Dated _____.

CUSTOM REDIRECT SERVICE

B. REGULATIONS (Cont'd)

2. Optional Features (Cont'd)

Number Identification Redirecting (Cont'd)

(x)

The customer may have as many numbers as desired on the list. The customer will be billed for each 100 numbers or any fraction thereof. Number Identification Redirecting may be used with any of the option columns. If this feature were used in more than one option, the optional feature charge would apply to each option utilizing the feature.

Number Identification may not be used to pass the calling party's number to the customer.

Percentage Redirecting

As an optional feature, redirecting may be done by percentages. For example, when Percentage Redirecting is activated, the customer may direct 20% of the incoming calls to location A, 30% to location B and 50% to location C. The customer may choose up to ten percentages, but the total must always equal 100%. The Percentage Redirecting feature may be used with any of the option columns. If this feature were used in more than one option, the optional feature charge would apply to each option utilizing the feature.

(x)

SuperGroups

A SuperGroup is similar to a distribution list of groups that will allow the customer to modify the active option of multiple groups at the same time.

Single Number Destination Service

This feature will allow customers to redirect an entire group to a single number provided at the time of activation. At the time of provisioning, customers must designate an interexchange carrier of their choice to carry the redirected traffic.

Time-of-Day/Day-of-Week Redirecting

An optional feature which allows customers to redirect the customer's calls to another location at pre-designated times. For example, particular numbers can be redirected to another location after 5 PM or just on Saturdays. The system will automatically route these calls until the customer changes the specifications. This will allow the customer to use a single office to perform the work of many locations during the off-peak hours. Time-of-Day/Day-of-Week Redirecting may be used with any of the option columns. If this feature were used in more than one option, the optional feature charge would apply to each option utilizing the feature.

(x) Indicates material transferred from 2nd Revised Page 3.

Issued by authority of an Order of the Public Service Commission of West Virginia in Case No. _____ dated _____.

CUSTOM REDIRECT SERVICE

B. REGULATIONS (Cont'd)

3. Conditions

This service is subject to the following conditions:

- a. Custom Redirect Service is available where Telephone Company facilities permit.
- b. Custom Redirect Service may be provisioned with group sizes as small as one.
- c. Each group may have up to three options for the basic rate. In most cases, the first option will be the called number leaving two additional options for the customer to define. If more than three options are requested, the Additional Option charges apply per additional option chosen. Up to six additional options may be provisioned as an enhancement to the Basic service. (C)
- d. Calls to telephone numbers associated with Custom Redirect Service must be redirected to a customer-specified number or to equipment such as an announcement or voice mail system.
- e. It is the responsibility of the Custom Redirect Customer redirecting calls to a third party to obtain, when appropriate, that third party's permission prior to the calls being redirected.
- f. Charges for calls between the Custom Redirect Service equipped-telephone number and the telephone number to which these calls are redirected are the responsibility of the CRS customer. In the event that the destination is outside the original LATA, the customer will provide to the Telephone Company the interexchange carrier to carry and complete the call.
- g. The customer must have sufficient lines and associated facilities to handle the estimated or actual number of calls without interfering with exchange or toll service. The Telephone Company reserves the right to disconnect the service immediately in accordance with the regulations contained in the General Regulations Tariff.
- h. Custom Redirect Service is not to be used by customers to avoid toll charges. If a customer is using this service to avoid such charges, the Telephone Company reserves the right to disconnect the service immediately and bill all appropriate toll charges.
- i. Custom Redirect Service will not be provided in connection with Public Telephone Service.
- j. When the service is originally ordered, a twelve-month termination liability will apply. If Custom Redirect Service is cancelled prior to the twelve-month period, the full monthly rate for each remaining month, or part thereof, will be charged. Changes to the original configuration shall not constitute a cancellation. (C)

GENERAL SERVICES TARIFF
P.S.C.-W.Va.-No. 203

Frontier West Virginia Inc.

Section 12
2nd Revised Page 5
Cancels 1st Revised Page 5

CUSTOM REDIRECT SERVICE

B. REGULATIONS (Cont'd)

3. Conditions (Cont'd)

- k. Customers with more than 500 lines provisioned may choose to sign a five-year contract, which will lower the monthly line rate. In the event the customer wishes to terminate the service prior to the end of the commitment period, the rate will be recalculated to the month-by-month rate and the twelve-month termination liability will apply.
- l. The Telephone Company assumes no liability for the redirecting of calls to numbers that are inaccurately provided to the Telephone Company by the customer.
- m. Initial Average Monthly Query Volumes are estimates only. After installation, Frontier will periodically and at our discretion, complete audits of number of queries and billing will be corrected if necessary to make adjustments to the monthly charges based upon the results of the audit.

(N)
|
(N)

Frontier West Virginia Inc.

Section 12
Original Page 6a

CUSTOM REDIRECT SERVICE

C. RATES

1. Application of Rates (Cont'd)

g. Redirecting Telephone Numbers

A monthly charge and a non-recurring installation charge for each telephone number assigned that will be used solely for the purpose of provisioning Custom Redirect Service. This telephone number will have no office equipment associated with it and will be used solely for the purpose of generating a trigger.

(N)

(N)

Issued by authority of an Order of the Public Service Commission of West Virginia
in Case No. _____ Dated _____.

CUSTOM REDIRECT SERVICE

C. RATES

1. Application of Rates

a. Equipped Numbers (C)

A monthly charge and a one-time installation charge for each telephone number assigned will apply solely for the purpose of provisioning Custom Redirect Service.

b. Service Establishment Charge

Charges will apply for the original order for Custom Redirect Service per Service Order or per Account. This charge will apply to New Orders of Custom Redirect Service. If a customer is modifying the existing order, including adding additional numbers, the Rearrangement Charge would apply. The addition of a new group, or a request for additional security forms, will result in a Service Establishment Charge. (C)

c. Rearrangement Charges

A nonrecurring charge will apply to each rearrangement. Each change to a main number, the addition of a telephone number to an existing group, or a telephone number moved from one group to another group incurs a rearrangement charge.

d. Password Initialization

This charge applies each time, after service establishment, that the customer requests that the Company reinitializes the pass code to the default pass code or is requested to modify existing security profiles. (C)

e. Group Charges (Average Monthly Query Volume) (C)

A monthly rate, in addition to a nonrecurring charge, will apply for each group of main numbers the customer designates. The monthly rate will be based on the estimated monthly volume of queries expected by the main numbers. A query is launched by the AIN database when a trigger is encountered. In basic implementations, query volume is equal to the call volume. As enhancements to the call processing logic are added and additional triggers are placed, the Query volume may exceed call volume.

f. Redirection Charges

There is no charge associated with modifying the active option. Customers may select to activate options as frequently as desired. When calls are redirected, the Custom Redirect subscriber will pay the portion of the call from the original called office to the termination number. The rate charged will be in accordance with the customer's current usage plan similar to a call transfer or a call forward.

Issued by authority of an Order of the Public Service Commission of West Virginia in Case No. _____ Dated _____.

GENERAL SERVICES TARIFF
P.S.C.-W.Va.-No. 203

Frontier West Virginia Inc.

Section 12
3rd Revised Page 7
Cancels 2nd Revised Page 7

CUSTOM REDIRECT SERVICE

C. RATES

1. Application of Rates (Cont'd)

h. Optional Feature Charges

(C)

Time-of-Day/Day-of-Week and Percentage Redirecting

A per-month and nonrecurring charge applies for each column equipped.

Subsequent changes to the routing schedule made by the customer via a touch-tone equipped-telephone may be made at no additional charge. Changes made by the Telephone Company will incur a rearrangement charge.

Auto Attendant Redirecting

Due to the custom nature of this feature, pricing will be developed for each application on an Individual Case Basis.

Number Identification Redirecting

A per-month charge and a nonrecurring charge applies to any combination of 100 telephone numbers, NXXs, NPAs, or LATAs, or fraction thereof, listed for Number Identification Redirecting.

SuperGroups

A nonrecurring charge will apply at the time of the establishment of this feature and a flat monthly rate will be billed for each group with this feature. When changes are made by the Company on behalf of the customer, rearrangement charges will apply.

Single Number Destination

A monthly and nonrecurring charge will apply for each group on which this feature is ordered.

Custom Application

A nonrecurring charge will apply at the time of the establishment of this feature and a flat monthly rate will be billed for each option with this feature. When changes are made by the Company on behalf of the customer, rearrangement charges will apply.

Issued by authority of an Order of the Public Service Commission of West Virginia
in Case No. _____ Dated _____.

GENERAL SERVICES TARIFF
P.S.C.-W.Va.-No. 203

Frontier West Virginia Inc.

Section 12
1st Revised Page 7a
Cancels Original Page 7a

CUSTOM REDIRECT SERVICE

C. RATES

1. Application of Rates (Cont'd)

g. Optional Feature Charges (Cont'd)

Alternate Central Office Trigger

A nonrecurring charge will apply at the time of the establishment of the trigger; and a flat monthly rate will be billed for each NPA-NNX trigger in each Central Office Switch in which a trigger is placed. (C)
When changes are made by the Company on behalf of the customer, rearrangement charges will apply. (C)

h. Special CRS Transactions

Occasionally, customers will require a one-time effort related to their CRS service. This may include the generation of a special report, out of hours programming support for testing, or other special handling of the service that was not included in the rate development for the service. This item will allow customers to request such services and the Company to recover the costs associated with these special requests. A negotiated nonrecurring charge based on estimated time/effort/value prior to the transaction will be charged, with a minimum charge of \$100.00 per request.

Issued by authority of an Order of the Public Service Commission of West Virginia
in Case No. _____ Dated _____.

Issued: September 30, 2004

Effective: October 14, 2004

GENERAL SERVICES TARIFF
P.S.C.-W.Va.-No. 203

Frontier West Virginia Inc.

Section 12
2nd Revised Page 8
Cancels 1st Revised Page 8

CUSTOM REDIRECT SERVICE

C. RATES

2. Rates and Charges

	<u>Installation Charge</u>	<u>Per Month</u>	<u>USOC</u>	
a. Service Establishment Charge..... Per Service Order or Account	\$500.00			(C) (C)
b. Equipped Number - Per telephone number equipped				(C)
1 - 50.....	\$2.35	\$2.50	R8SLX	
51 - 100.....	2.35	2.35	or	
101 - 500.....	2.35	2.00	R8SDX	
501 - 1000.....	2.35	1.50		
1000+	2.35	1.10		
500+ with 5-year contract.....	2.35	1.10	R8SCE or R8SDL	
c. Rearrangement Charges				(C)
Per occasion.....	\$250.00		NR9AD	(C)
Per number changed/moved/ added.....	2.35		NR9CD	(C)

GENERAL SERVICES TARIFF
P.S.C.-W.Va.-No. 203

Frontier West Virginia Inc.

Section 12
2nd Revised Page 9
Cancels 1st Revised Page 9

CUSTOM REDIRECT SERVICE

C. RATES (Cont'd)

2. Rates and Charges

	<u>Installation Charge</u>	<u>Per Month</u>	<u>USOC</u>	
d. Redirecting Telephone Number, each.....	\$ 5.00	\$ 1.00		R8W
e. Group Charges by monthly call volumes (Average Monthly Query Volumes) (Queries/Month/Group)				(C) (C)
Up to 1,000 calls per month.....	50.00	25.00		R8G1K
Up to 10,000 calls per month.....	50.00	80.00		R8G1A
Up to 25,000 calls per month.....	50.00	150.00		R8G2A
Up to 50,000 calls per month.....	50.00	280.00		R8G5A
Up to 75,000 calls per month.....	50.00	425.00		R8G7A
Up to 100,000 calls per month.....	50.00	550.00		R8G1B
Up to 250,000 calls per month.....	50.00	1,300.00		R8G2B
Up to 500,000 calls per month.....	50.00	2,500.00		R8G5B
Up to 750,000 calls per month.....	50.00	3,600.00		R8G7B
Up to 1,000,000 calls per month.....	50.00	4,500.00		R8G1C
Multiples of the above may apply.				
f. Optional features				
(1) Additional Options	200.00	25.00		R88 (R)
(per option over 3)				(C)
(2) Number Identification Redirecting				
Initial 100 numbers.....	500.00	50.00		R8N1X
Each additional 100 numbers or fraction thereof	100.00	10.00		R8NAX
(3) Percentage Redirecting				
Per arrangement.....	100.00	25.00		R8P
(4) Time-of-Day/Day-of-Week Redirecting				
Per arrangement.....	100.00	25.00		R8T

Issued by authority of an Order of the Public Service Commission of West Virginia
in Case No. _____ Dated _____.

GENERAL SERVICES TARIFF
P.S.C.-W.Va.-No. 203

Frontier West Virginia Inc.

Section 12
2nd Revised Page 10
Canceling 1st Revised Page 10

CUSTOM REDIRECT SERVICE

C. RATES (Cont'd)

2. Rates and Charges (Cont'd)

	<u>Installation Charge</u>	<u>Per Month</u>	<u>USOC</u>	
f. Optional features (Cont'd)				
(5) SuperGroups				
Per SuperGroup.....	\$ 50.00	\$ 1.00	R8XBX	
(6) Single Number Destination				
Per Group.....	50.00	10.00	R8XCX	
(7) Custom Application				
	200.00	25.00	R8XAX	
(8) Alternate Central Office Trigger ...				
Per Trigger, per switch	500.00	1.00	TGRAC	
(9) Special CRS Transaction				
	100.00	-	R8F	
g. Password Initialization, per occasion...	50.00	-	NR91P	(I)

Issued by authority of an Order of the Public Service Commission of West Virginia
in Case No. _____ Dated _____.

Issued: July 6, 2007

Effective: July 21, 2007

VACATION GET AWAY SERVICE

(N)

A. GENERAL

Vacation Get Away Service provides for temporary discontinuance of service at the customer's request without termination of the service.

B. REGULATIONS

1. Vacation Get Away Service applies to customers of Residential Exchange Access Service as well as vertical features, bundles and other basic services. Vacation Get Away Service is not available for Lifeline customers.
2. No outward or inward service is provided during the period of Vacation Get Away Service, except for 911 calls.
3. Vacation Get Away Service will not be made available for periods of less than two (2) months.
4. Vacation Get Away Service is available to a customer for a maximum period of nine (9) consecutive months. The customer's number must be working for at least 90 days in a calendar year.
5. During the period of Vacation Get Away Service, no installations, moves, changes or maintenance will be provided. Changes to billing address would be allowed.
6. The customer may request a restoration date in advance of the maximum allowable vacation period otherwise, complete service and billing will be restored on the last day of the maximum allowable vacation period of 9 months. A letter with the missed notifications will be sent to the customer at the time of restoral.
7. Monthly bills for services not covered by the Vacation Get Away Service during the vacation service period are to be paid in accordance with regular collection practices.
8. Vacation Get Away Service will be available where technically feasible.
9. Charges for Vacation Get Away Service will be a non-recurring charge to be billed in advance of the vacation service.

C. RATES

Nonrecurring Charge

Vacation Get Away Service

\$39.99

(N)

Issued by authority of an Order of the Public Service Commission of West Virginia in Case No. 19-1152-T-T dated December 13, 2019.

GENERAL SERVICES TARIFF
P.S.C.-W.Va.-No. 203

Frontier West Virginia Inc.

Section 14
5th Revised Page 1
Cancels 4th Revised Page 1

DEDICATED PRI SERVICE (C)

A. GENERAL

The Telephone Company provides two Dedicated PRI Services: Basic Dedicated PRI Service and Enhanced Dedicated PRI Hub Service. (C)

Basic Dedicated PRI Service (C)

Basic Dedicated PRI Service is an optional form of local exchange access based on the Primary Rate Interface (PRI) arrangement of the Integrated Services Digital Network (ISDN). Basic Dedicated PRI service provides a high-capacity access path for communications providing voice or data transmissions over the public network.

Enhanced Dedicated PRI Hub Service ** (LA-3) (C)

Enhanced Dedicated PRI Hub Service provides Information Services Remote Access Providers (ISRAPs) and their end user customers with a LATA-wide integrated voice/data communications capability for the transmission of circuit-switched voice and data signals. (C)

This Service offers single, LATA-wide telephone number connectivity from Telephone Company switches on a dial-up basis for the ISRAP's end user customers with transport to a designated hub interconnection within the LATA. From there the call continues to the ISRAP's premises location over dedicated high-speed access facilities purchased separately by the ISRAP.

The ISRAP must purchase suitable access facilities from its premises location to the Telephone Company's designated point of interconnection to handle the call volume in the LATA. In addition, the ISRAP must purchase a minimum of one PRI from each of the designated Enhanced Dedicated PRI Hub Service cluster hubs within a given LATA to receive LATA-wide coverage. (C)

The customer must specify either a 500-699-XXXX telephone number assigned by the Telephone Company or an NPA-555-XXXX number assigned by the North American Numbering Plan Administrator for use as Single Number Routing Service (SNRS). Single-number access routing will only work with Telephone Company NPA-NXX end offices equipped with the Advanced Intelligent Network (AIN) platform. The customer may also utilize local PRI telephone numbers to access Telephone Company end offices in which the PRI-SNRS is located (LA-3)*. Calls to the SNRS number will be charged to the originating party as a local call. Calls to the local PRI telephone number(s) will be charged to the originating party as either a local call or a toll call at rates specified in the Telephone Company's Local Exchange Service Tariff.

* (LA-3) No longer available to new customers as of April 20, 2005.

** (LA-3) No longer available to new customers as of May 31, 2006.

Issued by authority of an Order of the Public Service Commission of West Virginia in Case No. 11-0799-T-T dated June 21, 2011.

DEDICATED PRI SERVICE

(C)

B. REGULATIONS

1. Explanation of Terms

Advanced Intelligent Network (AIN)

The Advanced Intelligent Network is a telecommunications platform that utilizes the infrastructure of the existing switch-based network and Common Channel Signaling (CCS7) architecture. The AIN architecture introduces centralized computer devices to host service applications that are integrated with Stored Program Control switch resident software, CCS7 and Integrated Services Digital Network (ISDN) protocol.

Circuit Switching

Circuit Switching is a switching technique in which an entire circuit or, in a digital switch equipped for ISDN, a specific selection of time slots, is dedicated to a given call.

Enhanced Dedicated PRI Hub Service **(LA-3)

(C)

Enhanced Dedicated PRI Hub Service is a Telephone Company-designed LATA-wide network service from Telephone Company switches which allows ISRAPs to provide their end user customers with single-number dial-up access to the ISRAP's premises location. The service utilizes strategically located single-number-service hub offices to collect and route traffic using Advanced Intelligent Network features to predetermined points of interconnection, from where the traffic is routed to the ISRAP's premises location over dedicated facilities.

(C)

Dedicated Primary Rate Interface (PRI)

(C)

Dedicated PRI is an alternative for individual local exchange access loop services such as Direct Inward Dialing (DID), Direct Outward Dialing (DOD), Wide Area Telephone Service (WATS) Outward Service, WATS Toll Free Service and business trunks. Dedicated PRI is provisioned on the 1.544 megabit per second (mbps) bandwidth and uses the Integrated Services Digital Network (ISDN) architecture to provide the customer with the capabilities of simultaneous access, transmission and switching of voice, data and imaging services via channelized transport. In addition, Dedicated PRI provides the customer with the service capabilities and features described in B.3. and B.5. following.

(C)

(C)

(C)

Integrated Services Digital Network

Integrated Services Digital Network (ISDN) describes the end-to-end digital telecommunications network architecture which provides for the simultaneous access, transmission and switching of voice, data and image services. These functions are provided via channelized transport facilities over a limited number of standard user-network interfaces. The ISDN architecture consists of digital switching systems which connect Primary Rate Interface lines to their serving central office.

Network Interfaces

ISDN Primary Rate Interface is comprised of a limited set of standard user-network interfaces. The PRI customer premises equipment (CPE) located at the customer premises must be compatible with the network interface.

** (LA-3) No longer available to new customers as of May 31, 2006.

Issued by authority of an Order of the Public Service Commission of West Virginia in Case No. 11-0799-T-T dated June 21, 2011.

DEDICATED PRI SERVICE

(C)

B. REGULATIONS (Cont'd)

1. Explanation of Terms (Cont'd)

Optional Service Features Packages I and II

The Optional Service Features Package I incorporates the optional features Calling Line Identification and Call-by-Call Service Selection. The Optional Service Features Package II incorporates the optional features Calling Line Identification with Name, Redirecting Number and Call-by-Call Service Selection.

Primary Rate Access Facility

The Primary Rate Access Facility provides an optional high-capacity access path at a transmission speed of 1.544 megabits per second (mbps) for communications between the customer's premises and the central office. Each Primary Rate Access Facility supports one Dedicated PRI Interface Arrangement. High Capacity Access facilities from other Frontier tariffs may be used to provide PRI access. Customers may utilize alternate high capacity digital facilities (that meet the specifications as determined by the Company) in lieu of the ISDN PRI Facility. The applicable rules, regulations and rates from the appropriate Company Tariff will apply for the alternate high capacity digital facilities.

Primary Rate Interface (PRI) Arrangement

Dedicated PRI Arrangement is a customer premises-to-central office service providing ISDN capabilities. The PRI arrangement consists of 23 "B" channels and one "D" channel or 24 "B" channels, which are defined as follows:

B Channel

The B channel is a 64 kilobit per second (kbps) channel used for information transfer between users. The B channel may be used in conjunction with circuit-switched service.

D Channel

The D channel is a 64 kilobit per second (kbps) channel that carries signaling and control for the B channels.

Enhanced PRI - PRI Hub Service End Office Switch **(LA-3)

The Enhanced PRI Hub Service End Office Switch directs the ISRAP's end user calls to the PRIs connecting the subtending cluster hubs to the hub interconnection point. Dedicated high-speed access facilities purchased separately by the ISRAP carry the traffic to the ISRAP's premises location.

** (LA-3) No longer available to new customers as of May 31, 2006.

Issued by authority of an Order of the Public Service Commission of West Virginia in Case No. 11-0799-T-T dated June 21, 2011.

DEDICATED PRI SERVICE

(C)

B. REGULATIONS (Cont'd)

1. Explanation of Terms (Cont'd)

PRI Trunk Group

A PRI Trunk Group is a group of channels which are designated as one of the following:

- Incoming Exchange Trunk Group
- Outgoing Exchange Trunk Group
- Two-way Exchange Trunk Group
- Verizon WATS Trunk Group
- Verizon 800 Trunk Group
- Call-by-Call Service Trunk Group

Only one Call-by-Call Trunk group may be provisioned on an Dedicated PRI Arrangement. Where available, up to two trunk groups of each of the other trunk group types above may be provisioned on a PRI Arrangement. The total number of trunk groups is limited to four. The capability to assign other than Call-by-Call trunk groups varies by central office switch type. (C)

Remote/Host Switching Cluster

A Remote/Host Switching Cluster exists when the remote office is dependent on the host for its software call processing. A remote switch can process only intraoffice calls without the host switch.

Simulated Facility Group

A Simulated Facility Group is a software-defined register used to limit the number of simultaneous calls with specific attributes.

2. Customers subscribing to Basic Dedicated PRI service or Enhanced Dedicated PRI Hub Service must comply with ISDN Primary Rate Interface specifications, as designated by the Telephone Company. (C)

3. Service Capabilities

Basic Dedicated PRI provides the capability to:

(C)

- a. Transport customer information in the form of circuit-switched voice or data up to 64 kbps over any B channel.

GENERAL SERVICES TARIFF
P.S.C.-W.Va.-No. 203

Frontier West Virginia Inc.

Section 14
5th Revised Page 3
Cancels 4th Revised Page 3

DEDICATED PRI SERVICE

(C)

B. REGULATIONS (Cont'd)

3. Service Capabilities (Cont'd)

- b. Allow, where available, one D channel can control multiple PRI Interface Arrangements. In such cases, a single D channel in one PRI Interface Arrangement handles all the signaling and control requirements of multiple PRI Interface Arrangements in a specific grouping allowing supplemental PRI Interface Arrangements to consist of 24 B channels.

A 23B + Back-up D Interface Arrangement is required when two or more 24B PRI Interface Arrangements are ordered.

- c. Allow B channels to be allocated for specific services, such as Direct Inward Dialing (DID), and Direct Outward Dialing (DOD), Wide Area Telephone Service (WATS), and Toll Free Service, or optionally configure channels to access multiple services on a per call basis.

Two-way Exchange Trunks may not be accessed on a Call-by-Call basis.

- d. Allow the user to have access to the directory number of the calling party.

Enhanced Dedicated PRI Hub Service allows *(LA-3) : 1) ISRAPs to receive dial-up traffic from their end users utilizing local telephone numbers (LA-3)* or by dialing a single number; and 2) B channels to be provisioned as two-way service using Individual Additional Telephone Numbers or DID Numbers. WATS Toll Free Service is allowed. (C)

4. Conditions

The following conditions apply only to Basic Dedicated PRI Service, are common to both Basic Dedicated PRI Service and Enhanced Dedicated PRI Hub Service or apply only to Enhanced Dedicated PRI Hub Service: (C)

Conditions - Basic Dedicated PRI Service **only** (C)

- a. When more than one Frontier service is accessed over the PRI Arrangement in a DMS-100 office, Call-by-Call Service Selection is required.

* (LA-3) No longer available to new customers as of April 20, 2005.

** (LA-3) No longer available to new customers as of May 31, 2006.

Issued by authority of an Order of the Public Service Commission of West Virginia in Case No. 11-0799-T-T dated June 21, 2011.

Frontier West Virginia Inc.

Section 14
4th Revised Page 3a
Cancels 3rd Revised Page 3a

DEDICATED PRI SERVICE

(C)

B. REGULATIONS (Cont'd)

4. Conditions (Cont'd)

Conditions - Basic Dedicated PRI Service **only** (Cont'd)

(C)

- b. When, at the customer's request, this service is furnished from other than the normal serving central office, charges for foreign exchange and/or foreign central office interoffice mileage will apply per the DS1 interoffice mileage in this Company's tariffs. Foreign exchange and/or foreign central office charges do not apply when a customer is served from an alternate serving central office because the normal central is not equipped, as specified following.
- c. This service is available only from central offices which have the necessary facilities to provide ISDN on the standard ISDN network platform. In the event that a customer is served by a non conforming central office, the central office is out of capacity, or a central office that is part of a Remote Switching Cluster, the Company will attempt to provide ISDN service from an alternate serving central office in the same rate area, at no additional charge to the customer. Such provisioning may be elected where, in the discretion of the Company, service can be provided at a reasonable cost to the company. The local calling area and telephone numbers will be those associated with the customer's normal serving central office switch. The customer must accept the serving location assigned by the Company, and must agree to revert to the local serving central office at such time as ISDN service is available in that office.

If ISDN service is not available from a central office in the same rate area, the Telephone Company will attempt to provide service from an alternate serving central office, outside of the customer's normal rate area, at no additional charge to the customer, provided that the Company's existing rates for ISDN service cover any additional cost for service from the alternate serving central office.

Service from the alternate serving central office will also be subject to the following conditions.

If the customer accepts ISDN Primary from an alternate serving central office, the customer will also accept a number change to one associated with the alternate serving central office. The customer will also be subject to calling areas associated with the alternate serving central office as specified in Company tariffs, except in those situations where the alternate serving central office is part of a Remote Switching Cluster.

When ISDN service is available from the customer's normal serving central office, the customer may request service from the normal serving central office, and be subject to calling areas associated with the normal serving central office as specified in Company tariffs. If the customer does not wish to take service from the normal central office after ISDN service becomes available, but continues to utilize service from the alternate serving central office, charges for foreign exchange and/or foreign central office service may apply as specified in the Company's tariffs.

No charge will apply to transfer of this service back to the normal serving central office as set forth above.

Issued by authority of an Order of the Public Service Commission of West Virginia in Case No. 11-0799-T-T dated June 21, 2011.

Frontier West Virginia Inc.

Section 14
4th Revised Page 3b
Cancels 3rd Revised Page 3b

DEDICATED PRI SERVICE

(C)

B. REGULATIONS (Cont'd)

4. Conditions (Cont'd)

Conditions - Basic Dedicated PRI Service **only** (Cont'd)

(C)

- d. Each PRI trunk group is equipped with one telephone number. Additional numbers may be ordered in blocks of 20, as specified in Section 6 of this tariff, or ordered on an individual basis, as specified in C. following. DID trunk connection charges apply to DID numbers, but not to Individual Additional Telephone Numbers described in C. following.
- e. Telephone numbers ordered in blocks of 20 from Section 6 of this tariff and Individual Additional Telephone Numbers ordered from this tariff may be delivered on the same Simulated Facility Group. When telephone numbers are delivered over dedicated (non-Call-by-Call) trunk groups, telephone numbers ordered in blocks of 20 from Section 6 of this tariff and Individual Additional Telephone Numbers ordered from this tariff may be mixed on the same dedicated trunk group.
- f. The quantity of Individual Additional numbers may not exceed the size of the trunk group or Simulated Facility Group to which they are assigned.
- g. Basic Dedicated PRI service does not preclude the customer from originating or receiving circuit-switched voice calls from inside or outside either his/her serving central office or his/her Local Exchange Area. Where facilities are available, the customer will be able to originate and receive circuit-switched data calls outside of his/her serving central office. (C)
- h. PRI Station Detail billing is only available with message / measured usage service. Individual PRI Station Call Detail is for informational purposes only. Exact billing information is located in the Measured Call Summary portion of the bill.

The customer's ISDN Primary Service must be equipped with Calling Party Default Directory Number with the Calling Party Screening option. Customers will not have the option to change the Calling Party Number and CPN may not be deleted. Customers will have the option to define a partial listing in the screening list. Specific call details will not be provided for stations not included in the screening list. The screening list may not include 800 numbers, fictitious numbers, private network numbers or Centrex Dialing Plan numbers defined in the screening tables. Station Call Details will only be provided for valid telephone numbers within the switch providing the customer's ISDN Primary Service.
- i. ISDN PRI Service Portability is only available when there is an alternate switch in the same Rate Area, as defined by the Telephone Company, equipped with ISDN PRI equipment. When an alternate Telephone Company switch is not located in the same Rate Area as the normal serving switch, the customer may subscribe to ISDN Primary service from the alternate switch in another rate center and pay foreign exchange rates as defined elsewhere in this tariff.
 - 1. Tariff rates will apply for ISDN Primary Service Ports and Local Distribution Channels, if applicable.
 - 2. IOF mileage charges from the alternate switch apply as defined by the applicable High Capacity Facility tariff.
 - 3. Usage charges for originating calls will apply as determined by the applicable usage tariff.

Issued by authority of an Order of the Public Service Commission of West Virginia in Case No. 11-0799-T-T dated June 21, 2011.

GENERAL SERVICES TARIFF
P.S.C.-W.Va.-No. 203

Frontier West Virginia Inc.

Section 14
2nd Revised Page 3b.1
Cancels 1st Revised Page 3b.1

DEDICATED PRI SERVICE

(C)

B. REGULATIONS (Cont'd)

4. Conditions (Cont'd)

Conditions - Common to both Basic Dedicated PRI Service and Enhanced
Dedicated PRI Hub Service ** (LA-3). (C)

- a. Feature availability and service capabilities are dependent on the facilities and digital technology providing the service.
- b. ISDN-compatible terminal equipment is a requirement for operation. It is the customer's responsibility to power and obtain such equipment.
- c. This tariff does not apply to the transmission of packet data on the B or D channels.
- d. Existing local usage charges apply to circuit-switched voice calls.
- e. Circuit-switched data calls will be billed on a local usage-sensitive basis, as specified in this tariff. Toll charges will apply when circuit-switched data calls are made outside of the Local Exchange Area.
- f. All PRI Interface Arrangement configurations must have at least one 23B+D Interface Arrangement for signaling and control functions. A 23B + Back-up D Interface Arrangement is required whenever the Dedicated PRI Interface Arrangements ordered and in-service would otherwise cause more than 47 B-Channels to be controlled by a single D channel. (C)

Conditions - Enhanced Dedicated PRI Hub Service **only** ** (LA-3) (C)

- a. The customer must subscribe to a minimum of one Enhanced PRI at each of the hub end offices within the LATA for which service is being requested. In addition, the customer must purchase sufficient terminating facilities to permit the use of Enhanced Dedicated PRI Hub Service without injurious effect upon it or other services provided by the Telephone Company. Existing service may be terminated for such cause if, after written notification, the customer fails to take the necessary action to correct the situation. (C)

** (LA-3) No longer available to new customers as of May 31, 2006.

Issued by authority of an Order of the Public Service Commission of West Virginia in Case No. 11-0799-T-T dated June 21, 2011.

GENERAL SERVICES TARIFF
P.S.C.-W.Va.-No. 203

Frontier West Virginia Inc.

Section 14
4th Revised Page 3c
Cancels 3rd Revised Page 3c

DEDICATED PRI SERVICE

(C)

B. REGULATIONS (Cont'd)

4. Conditions (Cont'd)

Conditions - Enhanced Dedicated PRI Hub Service **only** (Cont'd) ******(LA-3) (C)

- b. Dedicated local distribution channels from the point of interconnection to the ISRAP's customer location are provided at rates and charges as specified elsewhere in this tariff for the facilities used to provide the service.
- c. Enhanced Dedicated PRI Hub Service is subject to the availability of the Advanced Intelligent Network capability, network facilities and billing capabilities. No mass calling type-services will be permitted until such time as Network Management capability is available. In no event shall the Telephone Company be liable for any losses or damages of any kind resulting from the unavailability or failure of its equipment or facilities or for any act, omission or failure of performance by the Telephone Company, its employees or agents. (C)
- d. Enhanced Dedicated PRI Hub Service calls from other Local Exchange Carriers, cell phones, and some hotels, etc., should use the local PRI Numbers to complete a call (LA-3)*, unless the calling party's carrier has made appropriate arrangements with the Telephone Company to complete calls to the Single Number routing arrangement. (C)
- e. Enhanced Dedicated PRI Hub Service is furnished upon the condition that the subscriber obtain adequate terminating facilities to permit the use of the service without injurious effect upon it or any other services rendered by the Telephone Company. (C)
- f. All calls utilizing Single Number Routing Service must originate and terminate within the same LATA.
- g. Individual Additional Telephone Numbers or DID Numbers can be used for Enhanced Dedicated PRI Hub Service. The quantity of Individual Additional Telephone Numbers may not exceed the size of the trunk group to which they are assigned. (C)

* (LA-3) No longer available to new customers as of April 20, 2005.

** (LA-3) No longer available to new customers as of May 31, 2006.

Issued by authority of an Order of the Public Service Commission of West Virginia in Case No. 11-0799-T-T dated June 21, 2011.

DEDICATED PRI SERVICE

(C)

B. REGULATIONS (Cont'd)

4. Conditions (Cont'd)

Conditions - Enhanced Dedicated PRI Hub Service **only** (Cont'd) ** (LA-3) (C)

- h. ISRAPs must abide by the limitations, restrictions, disclosures and other requirements set forth in the Telephone Disclosure and Dispute Resolution Act (TDDRA) of 1992. Under the statute, Federal Communications Commission's (FCC) regulations impose obligations and constraints on ISRAPs and common carriers that transmit or bill for informational program services. ISRAPs must also abide by the requirements set forth in the Federal Trade Commission (FTC) Telemarketing Act. Service to Enhanced Dedicated PRI Hub Service numbers with informational programs not in compliance with these requirements shall be terminated promptly after the Telephone Company's discovery of such programs' noncompliance. (C)
- i. The Telephone Company is only responsible for the maintenance and operation of the Enhanced Dedicated PRI Hub Service network facilities, and assumes no liability for the content(s) or accuracy of messages provided by the ISRAPs. (C)
- j. Calls to disconnected Enhanced Dedicated PRI Hub Service telephone numbers will be routed to a Vacant Code Announcement recording. (C)
- k. Enhanced Dedicated PRI Hub Single Number Routing Service numbers will not be listed in any Frontier Directory. (C)
- l. Calls dialed to an enhanced PRI hub service using the Telephone Company provided Single Number routing arrangement (e.g. 500-NXX-XXXX or 555-XXXX) must be delivered through end-to-end SS7 signaling, unless the calling party's carrier has made appropriate arrangements with the Telephone Company to complete calls with multi-frequency signaling. Calls attempted to Single Number address points that do not include ISUP parameters necessary to identify the originating callers location (Calling Party ID), that are normally included in SS7 carried traffic, will be blocked "Call forwarded" calls will not be accepted and will be blocked unless such arrangements have been made. (C)

5. Features

The following features are available only with Basic Dedicated PRI Service: (C)

a. Call-by-Call Service Selection

As an option to the Dedicated B Channel Configuration, B channels may be configured to access multiple services on a per-call basis. The customer premises equipment signals the local central office as to what type of service to access for each call.

** (LA-3) No longer available to new customers as of May 31, 2006.

Issued by authority of an Order of the Public Service Commission of West Virginia in Case No. 11-0799-T-T dated June 21, 2011.

DEDICATED PRI SERVICE

(C)

B. REGULATIONS (Cont'd)

5. Features (Con'td)

The following features are available only with Basic Dedicated PRI Service (Cont'd):

(C)

b. Remote/Host Number

Remote/Host Number is a standard arrangement which provides a customer that is served by a Remote/Host Switching Cluster, utilizing ISDN service from an alternate serving central office (Host), as described in 4.c. preceding, with numbers from the customer's normal serving central office (Remote), thereby retaining the calling area of the remote office. The customer's physical location must be in the remote switch calling area. If the customer's physical location is not in the remote switch calling area Dedicated PRI Foreign Exchange tariff rates apply. This feature is limited by availability of facilities and covers remote/host switching clusters only.

(C)

Hunting is not allowed between the Remote/Host Numbers and Dedicated PRI arrangements with the Host Numbers.

(C)

c. PRI Station Detail Billing

PRI Station Detail Billing - provides individual station call details for all stations utilizing a customer's ISDN Primary Service at an account level on a monthly basis. These details are provided with the normal customer bill or on the Frontier Communications Inc. website via the Internet. PRI Station Detail billing is only available with message / measured usage service. Individual PRI Station Call Detail is for informational purposes only. Exact billing information is located in the Measured Call Summary portion of the bill.

d. ISDN PRI Service Portability

ISDN PRI Service Portability allows a customer to request that all or a portion of their ISDN Primary Service and Telephone Numbers be provisioned from an alternate switch in the same rate area as defined by the Telephone Company.

DEDICATED PRI SERVICE

(C)

B. REGULATIONS (Cont'd)

5. Features (Con'td)

The following features are available with both Basic Dedicated PRI and
Enhanced Dedicated PRI Hub Service ** (LA-3):

(C)
(C)

a. Back-up D Channel

A Back-up D Channel automatically takes over for a failed D channel in case of trouble.

b. Calling Line Identification

Calling Line Identification allows the user to have access to the directory number of the calling party.

c. Calling Line Identification With Name

Calling Line Identification With Name allows the user to have access to the directory number and name of the calling party.

d. Modified Redirecting Number

The Modified Redirecting Number feature allows the number of the original called party number plus the last redirected calling party number to be passed to the end user when a call is forwarded or redirected. The Calling Line ID or Calling Line ID with Name will not show up as being transferred on the terminating CPE. The user must have Calling Line ID or Calling Line ID with Name plus Redirecting Number to enable this feature.

e. Redirecting Number

Redirecting Number allows the original calling party number plus the last calling party number to be passed to the end user when a call is forwarded to a PRI. The PRI will deliver the calling party number and the redirecting number. The user must have Calling Line ID or Calling Line ID with Name to enable this feature.

** (LA-3) No longer available to new customers as of May 31, 2006.

Issued by authority of an Order of the Public Service Commission of West Virginia in Case No. 11-0799-T-T dated June 21, 2011.

Frontier West Virginia Inc.

Section 14
8th Revised Page 4b
Cancels 7th Revised Page 4b

DEDICATED PRI SERVICE

(C)

B. REGULATIONS (Cont'd)

5. Features (Cont'd)

f. Two B Channel Transfer

The Two B Channel Transfer feature allows the CPE to accept a call from one user and, after accepting the call, the user can transfer the call to a user outside the CPE. Then both the incoming and outgoing B Channels are released for another call.

g. DID Trunk Package

Allows the customer the option to provision Dedicated PRI channels with DID capability on the trunks on a per PRI basis. The customer may elect to have any or all channels, excluding the D Channel to be used for DID service. (C)

h. Non-Hunt Directory Number

Allows a Non-Hunt Directory Number on an individual PRI or a Non Facility Associated Signaling (NFAS) multiline hunt group. This number allows testing on an individual PRI in a non-NFAS arrangement or on the entire multiline hunt group with NFAS.

The following features are available with the Term and Volume II package:

a. Standard Features - ISDN PRI Term & Volume II include:

- 1) Calling Line Identification
- 2) PRI DID Trunk Termination Charge

b. Optional Features:

- 1) All ISDN Primary Service Features identified in this tariff are available to ISDN PRI Term and Volume II Package subscribers at the rates, terms and conditions listed in this tariff.
- 2) When ISDN Term and Volume II facilities are purchased, customers may subscribe to Caller Line ID at no additional charge. Caller Line ID with name will be available at discounted rates, defined separately for ISDN for Term and Volume II subscribers.
- 3) When Term and Volume II Customers purchase DID trunks, there is no additional charge for DID trunk terminations or DID Trunk Package (if applicable). (A separate charge for DID TN's or DID TN blocks applies consistent with rates identified elsewhere in this tariff.)
- 4) Term and Volume II Package subscribers may subscribe to standard or Term and Volume features when a Term and Volume II rate is not available.
- 5) One and two Year Term and Volume II Package subscribers may subscribe to the standard optional feature month-to-month rate when a Term and Volume II rate is not available.

DEDICATED PRI SERVICE

(C)

B. REGULATIONS (Cont'd)

5. Features (Cont'd)

The following feature is available with Enhanced Dedicated PRI Hub Service only: (LA-3)*

(C)

- a. Alternate Translation Triggers will direct incoming calls to the Telephone Company's designated Enhanced PRI sector hub. This will allow direct routing of the call from the end user's central office to the sector hub. A customer may utilize multiple telephone numbers to provide coverage to part or all rate centers within a sector. Calls made to the Alternate Trigger telephone numbers will be charged to the originating party as either a local call or toll call at rates specified in the Telephone Company's Local Exchange Service Tariff for that rate center. This feature is not available without Enhanced PRI Hub Service.

6. Payment Options

A Basic Dedicated PRI customer may select a month-to-month option, a 5-year standard contract, a 2 or 3-year volume contract, or a 1, 2 or 3 year Volume II contract. All PRI services and features on a given customer's PRI must be subscribed to with the same payment option as the associated PRI, where available. However, Dedicated PRI customers that also subscribe to Company Rewards two or three year contracts may subscribe to Calling Line Identification and Calling Line Identification with Name on a 2- or 3- year volume contract basis. Two-year contract customers and 2- year Volume contract customers must subscribe to 3-year contract PRI features and services when 2-year contract rates are not available. The nonrecurring charge is waived for Dedicated PRI's and Dedicated PRI optional features on a 2- or 3-year volume contract, a 2- or 3-year Company Rewards contract, or a 1, 2 or 3 year Volume II contract. Two-year contract customers must subscribe to 3-year contract PRI features and services when 2-year contract rates are not available.

(C)

(C)

(C)

(C)

(C)

All of a customer's Telephone Company-provided PRIs within West Virginia will count towards the volume contract threshold. Volume contract customers may change the number of PRIs during the volume term period. In the event customers under a volume contract make subsequent PRI increases or decreases that cause the total number of PRIs to fall within a different threshold level, all remaining PRIs will be billed at the applicable level rate for the remainder of the volume contract term period. The customer must provide the account information of the PRIs included in the volume contract at the time of the initial installation of service and with each change to the service.

* (LA-3) No longer available to new customers as of April 20, 2005.

Frontier West Virginia Inc.

Section 14
6th Revised Page 4c
Cancels 5th Revised Page 4c

DEDICATED PRI SERVICE

(C)

B. REGULATIONS (Cont'd)

7. Termination Liability

The following regulation applies to both Basic Dedicated PRI Service and Enhanced Dedicated PRI Hub Service *(LA-3):

(C)

(C)

Subscribers under a two-year volume contract or a three-year standard contract, who disconnect Dedicated PRI services or features, in whole or in part, before expiration of the contract period, shall pay to the Telephone Company an early termination liability charge for each disconnected service or feature equal to the following: the difference between the applicable two-year contract or three-year standard contract recurring rate and the applicable month-to-month recurring rate multiplied by the number of months of the contract period that have elapsed as of the date of disconnection. If the customer disconnects before one year the nonrecurring rate should be recovered in full.

(C)

Subscribers under a three-year volume contract, who disconnect Dedicated PRI services or features, in whole or in part, before expiration of the contract period but after completion of the second year of a volume contract period, shall pay to the Telephone Company an early termination liability charge for each disconnected service or feature equal to the following: the difference between the applicable three-year volume contract period recurring rate and the applicable two-year volume contract period recurring rate multiplied by the number of months of the contract period that have elapsed as of the date of disconnection.

(C)

Customers on a contract plan may convert to a new contract plan without incurring termination liability charges provided the value of the new contract is equal to or greater than the remaining value of the existing term contract plan.

The following regulation applies only to Basic Dedicated PRI Service:

(C)

Subscribers under a five-year contract, who disconnect Dedicated PRI services or features, in whole or in part, before expiration of the contract period but after completion of the third year of the contract period, shall pay to the Telephone Company an early termination liability charge for each disconnected service or feature equal to the following: the difference between the applicable five-year contract period recurring rate and the applicable three-year contract period recurring rate multiplied by the number of months of the five-year contract period that have elapsed as of the date of disconnection.

(C)

Subscribers under a five-year contract period, who disconnect Dedicated PRI services or features, in whole or in part, before expiration of the third year of the contract period shall pay to the Telephone Company an early termination liability charge for each disconnected service or feature equal to the difference between the five-year contract recurring rate and the applicable month-to-month rate multiplied by the number of months of the contract period that have elapsed as of the date of disconnection. If the customer disconnects before one year the nonrecurring rate should be recovered in full.

(C)

Effective 1/30/2009, the Termination Liability will change for all new Standard term, Term and Volume Package, Term and Volume II Package contracts. When a subscriber terminates one of these plans prior to the expiration of the term, the subscriber will be subject to the termination liability equal to 25% of the monthly rate times the remaining months in the agreement.

Termination Liability does not apply to optional features. The termination liability charge will not apply when a customer converts from PRI Port and Access Facility to a PRI Port only when the PRI is connecting to an alternate high capacity facility.

** (LA-3) No longer available to new customers as of May 31, 2006.

Issued by authority of an Order of the Public Service Commission of West Virginia in Case No. 11-0799-T-T dated June 21, 2011.

DEDICATED PRI SERVICE

(C)

B. REGULATIONS (Cont'd)

8. Additions to Service

During the contract period, the customer may add PRI service at the same monthly rate as specified in the initial contract. The contract period for these additional services will not end concurrently with the initial contract for service installed after June 14, 2003.

9. Changes in future contract rates

If the monthly rates on a contract are lowered, the subscriber may be allowed to cancel their existing contract without penalty, providing they sign-up for a new contract of equal or greater monetary value. The subscriber will be subject to all terms, conditions and prices of the new contract.

10. Renewal Options

Prior to the expiration of the existing contract period, a customer may extend the contract for another contract period without incurring termination liability charges. The new contract will indicate the designated rates then in effect. The new contract period must be for a period of time which is equal to or greater than the remaining months in the old agreement. The contract period effective date will be the date the customer signs the new contract.

11. Relocation

When a customer elects to relocate his PRI service to a different premises not served by the same central office, prior to the expiration of a contract period, the service is considered to be disconnected, and the termination liability applies. However, if the customer relocates to a location served by a suitable equipped central office within the same State and establishes a PRI contractual payment plan of equal or greater monetary value, the customer may relocate without incurring any termination liability. Installation charges for establishing the new service would apply.

C. RATES

1. Application of Rates

- a. PBX trunk functionality is included in the Dedicated PRI Service rates and charges. (C)
- b. Existing tariff rates, charges and regulations for DID service apply, where required. The customer must choose one of these options; if DID trunks or DID numbers are present on the PRI; the DID Trunk connection charges on a per Channel basis, the PRI DID Trunk Package for a Month-to-Month arrangement, a 5 Year Contract, or the 2 or 3-Year Volume or Company Rewards Contract Package. (C)
- c. Customers accessing Telephone Company WATS Outward Service or WATS Toll Free Service via Dedicated PRI are also subject to the rates and charges specified in the Wide Area Telephone Service tariff. (C)

Issued by authority of an Order of the Public Service Commission of West Virginia in Case No. 11-0799-T-T dated June 21, 2011.

Issued: June 2, 2011

Effective: July 2, 2011

GENERAL SERVICES TARIFF
P.S.C.-W.Va.-No. 203

Frontier West Virginia Inc.

Section 14
1st Revised Page 5
Cancels Original Page 5

DEDICATED PRI SERVICE

(C)

C. RATES (Cont'd)

1. Application of Rates (Cont'd)

d. Circuit-Switched Data Usage Allowances

Circuit-Switched Data service is offered on an optional monthly allowance basis. For minutes of use over the monthly allowance specified for Circuit-Switched Data Usage Allowances, charges apply as specified following.

e. When DID numbers are ordered from Section 6 of this tariff, a DID trunk connection charge applies for each B channel dedicated for DID Service or Simulated Facility Group member over which the DID numbers are transmitted. Individual Additional Telephone Numbers may be ordered from this tariff without incurring DID trunk connection charges.

f. When a customer converts existing DS1 facilities provided under digital Hand-off Service or High-Capacity Digital Service as specified in the Channel Services Tariff, installation charges for the Primary Rate Access Facility are waived.

g. Trunk hunting is included in the Dedicated PRI Service rates and charges.

(C)

h. Installation charges for Dedicated PRI access are waived when a customer converts existing DS1 facilities from a Digital Hand-off Service or Digital High-Capacity Service, ordered from the Channel Services tariff, to Dedicated PRI Service.

(C)

(C)

Issued by authority of an Order of the Public Service Commission of West Virginia in Case No. 11-0799-T-T dated June 21, 2011.

GENERAL SERVICES TARIFF
P.S.C.-W.Va.-No. 203

Frontier West Virginia Inc.

Section 14
1st Revised Page 5a
Cancels Original Page 5a

DEDICATED PRI SERVICE

(C)

Issued by authority of an Order of the Public Service Commission of West Virginia
in Case No. 11-0799-T-T dated June 21, 2011.

Issued: June 2, 2011

Effective: July 2, 2011

Frontier West Virginia Inc.

DEDICATED PRI SERVICE

(C)

C. RATES (Cont'd)

2. Rates and Charges (Cont'd)

The following Rates and Charges apply only to Basic **IntelliLinQ** PRI Service

	Installation Charge	Per Month	USOC
a. Primary Rate Access Facility, each *			
Month-to-Month Option			
3-Year Contract			**
5-Year Contract			**
2 or 3 Yr. Volume Contract			
1 Year Volume II Package Contract			
2- or 3 Year Volume II Package Contract			
b. PRI Interface Arrangement, each *			
Standard *			
23B+D			
Month-to-month			**
3-Year Contract			**
5-Year Contract			**
24B			
Month-to-month			**
3-Year Contract			**
5-Year Contract			**
23B+ Back-up D			
Month-to-month			**
3-Year Contract			**
5-Year Contract			**
Volume, 23B+D, 24B, and 23B + Back-up D			
Package 1 (1 - 10 PRIs)			
2-Year Contract			
3-Year Contract			
Package 2 (11 - 20 PRIs)			
2-Year Contract			
3-Year Contract			
Package 3 (21+ PRIs)			
2-Year Contract			
3-Year Contract			
Volume II Package 23B +D, 24B and 23B + Back-up D			
1-Year Volume II Package Contract			
2-Year Volume II Package Contract			
3-Year Volume II Package Contract			

* Rates Deregulated.

** (LA-3) No longer available to new customers as of May 31, 2006.

Issued by authority of an Order of the Public Service Commission of West Virginia in Case No. 11-0799-T-T dated June 21, 2011.

GENERAL SERVICES TARIFF
P.S.C.-W.Va.-No. 203

Frontier West Virginia Inc.

Section 14
9th Revised Page 5c
Cancels 8th Revised Page 5c

DEDICATED PRI SERVICE

(C)

C. RATES (Cont'd)

2. Rates and Charges (Cont'd)	Installation Charge	Per Month	USOC
-------------------------------	------------------------	--------------	------

<p>d. Optional Service Features Package I and II Features Package I (Calling Line Identification and Call-by-Call Service Selection), per Dedicated PRI Arrangement *</p>			(C)
---	--	--	-----

Month-to-month	
3-Year Contract	
5-Year Contract	

<p>Features Package II (Calling Line Identification With Name, Redirecting Number, Call-by-Call Service Selection), per Dedicated PRI Arrangement</p>			(C)
---	--	--	-----

Month-to-month	
3-Yr. Contract	
5-Yr. Contract	

DID Trunk Package

Month-to-Month Arrangement*** ..		
2-Yr. Contract		**
3-Yr. Contract		**
5-Yr. Contract		

2 -Year Volume or Company Rewards Contract		(C)
---	--	-----

3 - Year Volume or Company Rewards Contract		(C)
1, 2 or 3 - Year Volume II package Contract		

<p>e. Call-by-Call Service Selection, per PRI Interface Arrangement*</p>			
Month-to-month			
3-Year Contract			
5-Year Contract			

<p>f. PRI Station Detail Billing, per account*</p>			
---	--	--	--

<p>g. ISDN Primary Service Portability, per PRI provisioned from an alternate switch*</p>			
---	--	--	--

* Rates Deregulated.

** (LA-3) No longer available to new customers as of May 31, 2006.

*** NRCs do not apply when this feature is provided at the time of the initial
Dedicated PRI installation. IF this feature is added subsequent to the initial
Dedicated PRI installation, a PRI Reconfiguration Charge - per change, applies as
specified for Dedicated PRI service. (C)

GENERAL SERVICES TARIFF
P.S.C.-W.Va.-No. 203

Frontier West Virginia Inc.

Section 14
6th Revised Page 5d
Cancels 5th Revised Page 5d

DEDICATED PRI SERVICE

(C)

C. RATES (Cont'd)

2. Rates and Charges (Cont'd)

The following Rates and Charges apply to both Basic Dedicated PRI Service and Enhanced Dedicated PRI Hub Service: ** (LA-3)

(C)

(C)

a.	Circuit-Switched Data Usage, per Account *	<u>Installation Charge</u>	<u>Per Month</u>	<u>USOC</u>	
	<u>Package</u>	<u>Monthly Allowance</u>			
	Option 1	None			
	Option 2	250 hours			
b.	Modified Redirecting Number, per Dedicated PRI Arrangement *				(C)
	Month-to-month				
	3-Yr. Contract				
	5-Yr. Contract				
c.	Redirecting Number, per Dedicated PRI Arrangement *				(C)
	Month-to-month				
	3-Yr. Contract				
	5-Yr. Contract				
d.	Calling Line Identification, per Dedicated PRI Arrangement *				(C)
	Month-to-month				
	3-Yr. Contract				**
	5-Yr. Contract				
	2 or 3 Yr. Volume Contract				
	1, 2 or 3 - Year Volume II				
	package Contract				

* Rates Deregulated.

** (LA-3) No longer available to new customers as of May 31, 2006.

Issued by authority of an Order of the Public Service Commission of West Virginia in Case No. 11-0799-T-T dated June 21, 2011.

GENERAL SERVICES TARIFF
P.S.C.- W.Va.-No. 203

Frontier West Virginia Inc.

Section 14
7th Revised Page 5e
Cancels 6th Revised Page 5e

DEDICATED PRI SERVICE

(C)

C. RATES (Cont'd)

2. Rates and Charges (Cont'd)	<u>Installation</u> <u>Charge</u>	<u>Per</u> <u>Month</u>	<u>USOC</u>
-------------------------------	--------------------------------------	----------------------------	-------------

The following Rates and Charges apply to both Basic Dedicated PRI Service and Enhanced Dedicated PRI Hub Service: ** (LA-3) (C)
(C)

e. Calling Line Identification With Name, per Dedicated PRI Arrangement * (C)

Month-to-month			
3-Yr. Contract			**
5-Yr. Contract			
2 or 3 Yr. Volume Contract			
1, 2 or 3 - Year Volume II package Contract			

f. Two B Channel Transfer, per Dedicated PRI Arrangement * (C)

Month-to-month	
3-Yr. Contract	
5-Yr. Contract	

g. Trunk Change Charge - add/change to existing trunk group, or addition of new trunk group, per occasion *

Change in D-channel configuration (23B+D, 24B, 23B+BU-D), per PRI Arrangement *

h. Individual Additional Telephone Number, each *

i. Non-Hunt Directory Number, each *

Month-to-month	
3-Yr. Contract	
5-Yr. Contract	

* Rates Deregulated.

** (LA-3) No longer available to new customers as of May 31, 2006.

Issued by authority of an Order of the Public Service Commission of West Virginia in Case No. 11-0799-T-T dated June 21, 2011.

GENERAL SERVICES TARIFF
P.S.C.- W.Va.-No. 203

Frontier West Virginia Inc.

Section 14
6th Revised Page 5f
Cancels 5th Revised Page 5f

DEDICATED PRI SERVICE

(C)

C. RATES (Cont'd)

2. Rates and Charges (Cont'd)	<u>Installation</u> <u>Charge</u>	<u>Per</u> <u>Month</u>	<u>USOC</u>
-------------------------------	--------------------------------------	----------------------------	-------------

The following Rates and Charges apply only to Enhanced Dedicated PRI Hub Service ** (LA-3): (C)

a. Enhanced Dedicated PRI Hub Service, (C)
per Dedicated PRI Arrangement * (C)

Standard

Month-to-month
3-Yr. Contract

Volume, 23B+D, 24B, and 23B +
Back-up D

Package 1 (1 - 10 PRIs)

2-Year Contract
3-Year Contract

Package 2 (11 - 20 PRIs)

2-Year Contract
3-Year Contract

Package 3 (21+ PRIs)

2-Year Contract
3-Year Contract

b. Alternate Translations Trigger
Number, each (LA-3)*

* (LA-3) No longer available to new customers as of April 20, 2005.

** (LA-3) No longer available to new customers as of May 31, 2006.

Issued by authority of an Order of the Public Service Commission of West Virginia in Case No. 11-0799-T-T dated June 21, 2011.

Issued: June 2, 2011

Effective: July 2, 2011

GENERAL SERVICES TARIFF
P.S.C.-W.Va.-No. 203

Frontier West Virginia Inc.

Section 14A
3rd Revised Page 1
Cancels 2nd Revised Page 1

INDIVIDUAL LINE BUSINESS DEDICATED BRI SERVICE - Grandfathered ¹ (C)

A. GENERAL

Individual Line Business Dedicated BRI Service is an optional service arrangement for use with Individual Line Business Service. Dedicated uses the Basic Rate Interface (BRI) arrangement of the Integrated Services Digital Network (ISDN).

B. REGULATIONS

1. Explanation of Terms

Basic Rate Interface (BRI) Arrangement

Dedicated BRI Arrangement provides ISDN capabilities from an ISDN equipped switch in the central office. The BRI Arrangement consists of two "B" channels and one "D" channel (2B+D) which are defined as:

B Channel

The B channel is a 64 kilobit per second (kbps) channel used for information transfer between users. The B channel may be used in conjunction with circuit-switched service.

D Channel

The D channel is a 16 kilobit per second packet-switched channel that carries signaling and control for the B channels and also supports customer packet traffic at speeds up to 9.6 kbps. * (LA-3)

Circuit Switching

Circuit Switching is a switching technique in which an entire circuit or, in a digital switch equipped for ISDN, a specific selection of time slots is dedicated to a given call.

Closed User Groups

Allows the user to establish subnetworks within which the members of the Closed User Group can communicate. Each data terminal in a Closed User Group can be arranged in one of the following modes:

a. Closed User Group with Outgoing Access

The data terminal makes outgoing calls only.

* Effective February 15, 2008, D Channel Packet-Switched Data service features associated with Dedicated BRI Service are grandfathered and no longer available to new customers. Moves, additions or changes to subscribers' existing service will not be permitted.

¹ ISDN-BRI is grandfathered and limited to existing customers at existing locations as of March 18, 2022. Moves, additions or changes will not be permitted. (N)
(N)

Issued by authority of an Order of the Public Service Commission of West Virginia in Case No. 22-0217-T-T dated February 25, 2022.

GENERAL SERVICES TARIFF
P.S.C.-W.Va.-No. 203

Frontier West Virginia Inc.

Section 14A
3rd Revised Page 2
Cancels 2nd Revised Page 2

INDIVIDUAL LINE BUSINESS DEDICATED BRI SERVICE - Grandfathered ¹

(C)

B. REGULATIONS (Cont'd)

1. Explanation of Terms (Cont'd)

Closed User Groups (Cont'd)

b. Closer User Group with Incoming Access

The data terminal receives incoming calls only.

c. Incoming Calls Barred within a Closed User Group

The data terminal originates outgoing calls only to the data terminals in the Closed User Group with which it is associated.

d. Outgoing Calls Barred within a Closed User Group

The data terminal receives incoming calls only from the data terminals in the Closed User Group with which it is associated.

e. Unrestricted Access

The data terminal receives and originates both incoming and outgoing calls.

D Packet Dedicated BRI Access* (LA-3)

D Packet Dedicated BRI Access (OB+D) has no applications on the B channels and uses only the D channel of the ISDN architecture for providing packet-switched data.

Electronic Key Feature Package

The Electronic Key Feature Package incorporates all the Electronic Key Features in 5. following into one installation charge and one monthly rate.

Featured Voice Dedicated BRI Access

Featured Voice Dedicated BRI Access uses only one B channel of the ISDN architecture for providing voice access and includes the Electronic Key Features in 5. following.

* Effective February 15, 2008, D Channel Packet-Switched Data service features associated with Dedicated BRI Service are grandfathered and no longer available to new customers. Moves, additions or changes to subscribers' existing service will not be permitted.

¹ ISDN-BRI is grandfathered and limited to existing customers at existing locations as of March 18, 2022. Moves, additions or changes will not be permitted.

(N)
(N)

Issued by authority of an Order of the Public Service Commission of West Virginia in Case No. 22-0217-T-T dated February 25, 2022.

GENERAL SERVICES TARIFF
P.S.C.-W.Va.-No. 203

Frontier West Virginia Inc.

Section 14A
2nd Revised Page 3
Cancels 1st Revised Page 3

INDIVIDUAL LINE BUSINESS DEDICATED BRI SERVICE - Grandfathered ¹

(C)

B. REGULATIONS (Cont'd)

1. Explanation of Terms (Cont'd)

Integrated Services Digital Network

Integrated Services Digital Network (ISDN) describes the end-to-end digital telecommunications network architecture which provides for the simultaneous access, transmission and switching of voice, data and image services. These functions are provided via channelized transport facilities over a limited number of standard user-network interfaces. The ISDN architecture consists of digital switching systems which connect Basic Rate Interface lines to their serving central office.

Dedicated Basic Rate Interface (BRI)

Dedicated BRI is an optional service arrangement which can be used in conjunction with a customer's Individual Line Business service. It uses the ISDN architecture to provide the customer with the capabilities of simultaneous access, transmission and switching of voice, data and image services via channelized transport. In addition, Dedicated BRI provides the customer with the service capabilities and features described in 3., 5. and 6. following.

Multiple Access Dedicated BRI

Multiple Access Dedicated BRI utilizes both B channels of the ISDN architecture for either voice or circuit-switched data and also applies when only one B channel is utilized for circuit-switched data or alternate voice/data.

Network Interfaces

ISDN Basic Rate Interface is comprised of a limited set of standard user-network interfaces. The BRI customer premises equipment (CPE) located at the customer premises must be compatible with the network interface. This interface is defined as follows:

A two-wire interface is the physical interface between a switch equipped with ISDN and the network termination (NT1). The NT1 is customer premises equipment which is necessary for terminating a telephone circuit or facility at the customer premises.

¹ ISDN-BRI is grandfathered and limited to existing customers at existing locations as of March 18, 2022. Moves, additions or changes will not be permitted.

(N)
(N)

Issued by authority of an Order of the Public Service Commission of West Virginia in Case No. 22-0217-T-T dated February 25, 2022.

GENERAL SERVICES TARIFF
P.S.C.-W.Va.-No. 203

Frontier West Virginia Inc.

Section 14A
2nd Revised Page 4
Cancels 1st Revised Page 4

INDIVIDUAL LINE BUSINESS DEDICATED BRI SERVICE - Grandfathered ¹

(C)

B. REGULATIONS (Cont'd)

1. Explanation of Terms (Cont'd)

Packet Data Feature Package

The Packet Data Feature Package incorporates all the X.25 Packet Data Features shown in 6. following into one installation charge and one monthly rate.

Packet Switching

A switching technique in which packets of data are individually addressed and combined on a transmission path with other addressed packets. The maximum packet transmission rate for Basic Rate Interface is 9.6 kbps on the D-channel.

Secondary Directory Number

An ISDN Secondary Directory Number (SDN) is a software defined number that is assigned to a station with an actual telephone number and provides the user the capability to originate and receive calls over the SDN. SDN calls utilize the same facilities as the primary directory number and originating calls assume the characteristics of the station that the SDN is assigned to.

X.25

X.25 is the Consultative Committee on International Telephone and Telegraph's (CCITT) recommended and internationally accepted standard for connecting computers to packet switched networks.

2. Customers subscribing to Individual Line Business Dedicated BRI must comply with ISDN Basic Rate Interface specifications as specified by the Telephone Company.

3. Service Capabilities

Customers can configure Individual Line Business Dedicated BRI using the following service capabilities:

- a. Featured voice on the B channel(s).
- b. Circuit-switched data on the B channel(s) at speeds up to 64 kbps.

¹ ISDN-BRI is grandfathered and limited to existing customers at existing locations as of March 18, 2022. Moves, additions or changes will not be permitted.

(N)
(N)

Issued by authority of an Order of the Public Service Commission of West Virginia in Case No. 22-0217-T-T dated February 25, 2022.

GENERAL SERVICES TARIFF
P.S.C.-W.Va.-No. 203

Frontier West Virginia Inc.

Section 14A
3rd Revised Page 5
Cancels 2nd Revised Page 5

INDIVIDUAL LINE BUSINESS DEDICATED BRI SERVICE - Grandfathered ¹

(C)

B. REGULATIONS (Cont'd)

3. Service Capabilities (Cont'd)

- c. Packet-switched data on the D channel at speeds up to 9.6 kbps.* (LA-3)
- d. Alternating circuit-switched voice and circuit-switched data on the same B channel.

4. Conditions

This service is offered subject to the following conditions:

- a. Existing local usage charges apply to circuit-switched voice calls and D channel packet-switched data calls.
- b. Circuit-switched data calls will be billed on a local usage-sensitive basis as specified in this tariff. Toll charges will apply when circuit-switched data calls are made outside of the Local Service Area.
- c. Packet data calls and features will be billed the Public Data Network rates specified in the Telephone Company's appropriate tariffs.
- d. ISDN compatible terminal equipment is a requirement for operation. It is the customer's responsibility to power and obtain such equipment.
- e. ISDN charges are in addition to applicable rates and charges associated with Individual Line Business Service.
- f. This service is available only from central offices which have the necessary facilities to provide ISDN service on the standard ISDN network platform. In the event that a customer is served by a non conforming office, the Company may, at its option, provide ISDN service from an alternate serving central office at no additional charge to the customer. Such provisioning may be elected where, in the discretion of the Company, service can be provided at a reasonable cost to the Company. The customer must accept the serving location assigned by the Company and must agree to revert to service from the normal serving central office at such time as ISDN service is available in that office.

If ISDN service is provided from an alternate serving central office, the customer will accept a number change to one associated with the alternate serving central office. The customer will also be subject to calling areas associated with the alternate serving central office as established in Company tariffs.

* Effective February 15, 2008, D Channel Packet-Switched Data service features associated with Dedicated BRI Service are grandfathered and no longer available to new customers. Moves, additions or changes to subscribers' existing service will not be permitted.

¹ ISDN-BRI is grandfathered and limited to existing customers at existing locations as of March 18, 2022. Moves, additions or changes will not be permitted.

(N)
(N)

Issued by authority of an Order of the Public Service Commission of West Virginia in Case No. 22-0217-T-T dated February 25, 2022.

GENERAL SERVICES TARIFF
P.S.C.-W.Va.-No. 203

Frontier West Virginia Inc.

Section 14A
2nd Revised Page 5a
Cancels 1st Revised Page 5a

INDIVIDUAL LINE BUSINESS DEDICATED BRI SERVICE - Grandfathered ¹

(C)

B. REGULATIONS (Cont'd)

4. Conditions (Cont'd)

f. (Cont'd)

When ISDN service is available from the customer's normal serving central office, the customer will revert to and accept a number change to one associated with the normal serving central office and be subject to calling areas associated with the normal serving central office as specified in Company tariffs. If the customer does not wish to take service from the normal central office after such service becomes available, but continues to utilize service from the alternate serving central office, charges for foreign exchange and/or foreign central office service will apply as specified in the Company's tariffs.

No charge will apply to transfer of this service back to the normal serving central office as set forth above.

In addition, the customer's service location must be within the distance limitations determined during installation of the service in the sole judgement and discretion of the Company. When a customer requests ISDN service and requires the installation of additional facilities due to exceeding the distance limitation determined by the Company and where, in the judgement of the Company, it is practical to provide such facilities, the customer will be charged rates and charges based on the cost of providing the necessary additional facilities, in addition to the rates and charges specified in C. following. These charges for any additional facilities required will be computed on an individual case basis.

- g. Electronic Key Feature and X.25 Packet Data Feature availability is dependent on the facilities providing the service. No credit is given on the package rate for features where facilities and appropriate digital technology are not available.

¹ ISDN-BRI is grandfathered and limited to existing customers at existing locations as of March 18, 2022. Moves, additions or changes will not be permitted.

(N)
(N)

Issued by authority of an Order of the Public Service Commission of West Virginia in Case No. 22-0217-T-T dated February 25, 2022.

INDIVIDUAL LINE BUSINESS DEDICATED BRI SERVICE - Grandfathered ¹

(C)

B. REGULATIONS (Cont'd)

4. Conditions (Cont'd)

- h. Electronic Key Features and Packet Data Features may be selected individually or as feature packages on a per service basis. With the exception of Multiple Call Appearance and Shared Call Appearances for a Directory Number, rates and charges for Individual Line Business Dedicated BRI service provide for single appearances of Electronic Key Features on the same channel. If the customer desires multiple appearances of the same electronic key feature, other than Multiple Call Appearance or Shared Call Appearances for a Directory Number, on the same channel, rates and charges as specified elsewhere in this tariff will apply for all appearances other than the first appearance.
- i. This tariff does not apply to the transmission of packet data on the B channel. Packet data and the B channel may be provided on an individual case basis.
- j. Individual Line Business Dedicated BRI service does not preclude the Individual Line Business customer from originating or receiving circuit-switched voice calls from inside or outside either his/her serving central office or his/her Local Service Area. Where facilities are available, the customer will be able to originate and receive circuit-switched data and packet-switched data calls outside of his/her serving central office.
- k. Calls identified as circuit-switched data will be billed at Circuit-Switched Data Usage rates even if the customer's equipment establishes the call as circuit-switched voice service and then transmits 56 kbps or 64 kbps circuit-switched data.

5. Electronic Key Features

Electronic Key Features provides the customer with the ability to access the following features where available:

a. Automatic Exclusion

Automatically inhibits other stations from picking up a call on hold or bridging onto a call that is active at that station. This feature must be used in conjunction with Shared Call Appearances for a Directory Number.

b. Call Pickup - Originating and Terminating

Allows a station user to answer any call within an associated preset pickup group. If more than one line within the pickup group has an unanswered incoming call, the call to be answered is selected by the switching system.

¹ ISDN-BRI is grandfathered and limited to existing customers at existing locations as of March 18, 2022. Moves, additions or changes will not be permitted.

(N)
(N)

Issued by authority of an Order of the Public Service Commission of West Virginia in Case No. 22-0217-T-T dated February 25, 2022.

INDIVIDUAL LINE BUSINESS DEDICATED BRI SERVICE - Grandfathered ¹

(C)

B. REGULATIONS (Cont'd)

5. Electronic Key Features (Cont'd)

c. Drop

Allows the user to drop the last party added to a conference call. For a two-party call, this will terminate the call. This feature must be used in conjunction with three-way calling.

d. Feature Function Button

Allows the user to assign certain features to a particular button on his/her ISDN set. When depressed the button will activate the assigned feature.

e. Hold

Allows the user to place a call on hold.

f. Individual Calling Line Identification

Allows the user to have access to the directory number and/or name of the calling party.

g. Key System Coverage for Analog Lines

Allows an ISDN set to provide call coverage for an analog set.

h. Multiple Call Appearances of a Directory Number

Allows the user to have more than one appearance of his/her directory number assigned to his/her set, providing the capability of multiple incoming or outgoing calls associated with that directory number. Multiple incoming calls to this directory number can be terminated to the telephone if idle call appearances are available to accept the calls.

i. Outgoing Called Line Identification for ISDN Sets

Provides a user originating a call with information about the called party and the facility or destination.

j. Shared Call Appearances for a Directory Number

Allows a directory number from one terminal to appear as a call appearance on the terminals of other users.

¹ ISDN-BRI is grandfathered and limited to existing customers at existing locations as of March 18, 2022. Moves, additions or changes will not be permitted.

(N)
(N)

INDIVIDUAL LINE BUSINESS DEDICATED BRI SERVICE - Grandfathered ¹

(C)

B. REGULATIONS (Cont'd)

5. Electronic Key Features (Cont'd)

k. Short Hunt

Permits incoming calls to hunt over a set of directory number appearances in search of an idle directory number on which to terminate.

6. X.25 Packet Data Features* (LA-3)

X.25 Packet Data Features provides the customer with the ability to access the following features where available:

a. Fast Select* (LA-3)

Allows a sending data terminal to forward up to 128 bytes of data along with the call setup and clearing packets.

b. Fast Select Acceptance* (LA-3)

Allows the switch to transmit incoming call packets with the fast select facility to a destination terminal that has this feature.

c. Flow Control Parameter Negotiation* (LA-3)

Permits negotiation on a per call basis of the flow control parameters. Automatically negotiates the maximum packet size and window size for each direction of data transmission.

d. Hunt Groups* (LA-3)

Allows a grouping of access lines such that an incoming packet-switched data call to the hunt group is completed if there is a logical channel on any of the access lines within the hunt group. The hunt group cannot span switches.

e. Incoming Calls Barred* (LA-3)

Prohibits a data terminal from receiving an incoming call.

f. Non-Standard Default Packet Sizes* (LA-3)

Allows the user to subscribe to a larger maximum packet size of 256 octets for each direction of communication than the default 128 octets normally provided. In order to have this capability, the user must also subscribe to the Flow Control Parameter Negotiation feature.

* Effective February 15, 2008, D Channel Packet-Switched Data service features associated with Dedicated BRI Service are grandfathered and no longer available to new customers. Moves, additions or changes to subscribers' existing service will not be permitted.

¹ ISDN-BRI is grandfathered and limited to existing customers at existing locations as of March 18, 2022. Moves, additions or changes will not be permitted.

(N)
(N)

INDIVIDUAL LINE BUSINESS DEDICATED BRI SERVICE - Grandfathered ¹

(C)

B. REGULATIONS (Cont'd)

6. X.25 Packet Data Features (Cont'd)

g. Non-Standard Default Window Sizes* (LA-3)

Allows the user to subscribe to values for outgoing and incoming window sizes which are different than the standard network default. In order to have this capability, the user must also subscribe to the Flow Control Parameter Negotiation feature.

h. Outgoing Calls Barred

Prohibits a data terminal from originating outgoing calls.

i. Throughput Class Negotiation

Allows the calling data terminal to request specific throughput classes in the call request packet for both directions of data transmission.

7. Virtual Office ISDN (VOI)

a. Virtual Office ISDN (VOI) provides the following Dedicated BRI services and features for a single monthly rate:

Multiple Access Dedicated BRI - including the following system features:

- Circuit-Switched Data on the B channel(s)
- Alternate Circuit-Switched Voice and Data on the B channel(s)
- Configuration Group

Electronic Key Feature Package - the user has the option to order the other features within this package. The features below must be a part of this offering.

- Three Call Appearances
- Individual Calling Line Identification
- Hold
- Drop
- Transfer
- Conference
- Call Forwarding Variable

Unlimited Circuit-Switched Data Local Usage - the user is not billed for Local Circuit-Switched Data usage.

* Effective February 15, 2008, D Channel Packet-Switched Data service features associated with Dedicated BRI Service are grandfathered and no longer available to new customers. Moves, additions or changes to subscribers' existing service will not be permitted.

¹ ISDN-BRI is grandfathered and limited to existing customers at existing locations as of March 18, 2022. Moves, additions or changes will not be permitted.

(N)
(N)

INDIVIDUAL LINE BUSINESS DEDICATED BRI SERVICE - Grandfathered ¹

(C)

B. REGULATIONS (Cont'd)

7. Virtual Office ISDN (VOI) (Cont'd)

b. Conditions:

Customer may have no more than two packages per premise.

The total monthly rate applies whether or not all of the features in the package are activated.

VOI is only available on classes of service that are measured services.

Customer may purchase the package on a month-to-month basis or on a contract basis for two, three, or five years.

Minimum service requirement is one month for month-to-month. For contract rates, the minimum service requirement is determined by the contract.

If a customer under a two-year contract terminates service during the first year of the contract, the customer will pay early termination charges. If the customer terminates service after the twelfth month of service, the customer will not pay termination charges. The customer must contact the Company prior to the end of the contract period in order to renew the contract for additional periods of time. The customer may renew for two, three or five years. If the customer does not renew before the end of the contract period, the rate will revert to the month-to-month rate.

The customer under a three or five-year contract must contact the Company prior to the end of the contract to renew the contract. The customer has the option to renew for two, three or five years. If the customer does not renew before the end of the contract, the rate will revert to the month-to-month rate. If the customer terminates service during the initial or any renewal period of the contract, early termination charges will apply.

Early termination charges will be calculated by taking the difference between the month-to-month rate and the contract rate and multiplying by the number of months in service.

All regulations and conditions for Dedicated BRI service apply to this offering.

¹ ISDN-BRI is grandfathered and limited to existing customers at existing locations as of March 18, 2022. Moves, additions or changes will not be permitted.

(N)
(N)

GENERAL SERVICES TARIFF
P.S.C.-W.Va.-No. 203

Frontier West Virginia Inc.

Section 14A
2nd Revised Page 9b
Cancels 1st Revised Page 9b

INDIVIDUAL LINE BUSINESS DEDICATED BRI SERVICE - Grandfathered ¹ (C)

C. RATES

1. Application of Rates

a. Dedicated BRI Access

(1) Service Capability Charges

(a) Monthly Rate

Monthly rates for Service Capabilities apply per Service Capability provided.

(b) Installation Charge

The Installation Charge applies per termination for the installation or the move of the Dedicated BRI Access.

(2) Change Charge

The Change Charge applies per Individual Line Business Dedicated BRI Service configuration for customer requested changes to or addition of call appearances, adding or changing features in an existing configuration group, and adding or changing Dedicated BRI features.

¹ ISDN-BRI is grandfathered and limited to existing customers at existing locations as of March 18, 2022. Moves, additions or changes will not be permitted. (N)
(N)

Issued by authority of an Order of the Public Service Commission of West Virginia in Case No. 22-0217-T-T dated February 25, 2022.

GENERAL SERVICES TARIFF
P.S.C.-W.Va.-No. 203

Frontier West Virginia Inc.

Section 14A
7th Revised Page 10
Cancels 6th Revised Page 10

INDIVIDUAL LINE BUSINESS DEDICATED BRI SERVICE - Grandfathered ¹ (C)

C. RATES (Cont'd)

1. Application of Rates (Cont'd)

a. Dedicated BRI Access (Cont'd)

(3) Configuration Group Charge

The Configuration Group Charge applies per configuration group established in excess of one group on the initial establishment of Dedicated BRI and any configuration group requested after the initial establishment of service.

2. Rates and Charges

	Installation Charge	Per Month	
a. Change Charge.....	\$ 2.00	-	(C)
b. Configuration Group Charge, per group established in excess of one group on the initial Dedicated BRI installation....	37.00	-	(C)
c. Closed User Group, per group established	69.00	-	(C)
per user assigned to a Closed User Group.....	9.75	-	(C)
d. Secondary Directory Number, per number established.....	-	\$3.85	(C)
e. D Packet Dedicated BRI Access, per individual line*.....	36.50	12.71	(C)
D Channel Packet-Switched Data, per service provided.†** (LA-3) ...	14.50	4.00	(C)

* Dedicated BRI rates and charges are in addition to other applicable Individual Line Business service arrangement rates and charges as specified in the appropriate Telephone Company Tariffs.

† Customers subscribing to D Channel Packet-Switched Data will be billed for Public Data Network (PDN) service as specified in the Frontier Telephone Companies Tariff FCC No. 4.

** Effective February 15, 2008, D Channel Packet-Switched Data service features associated with Dedicated BRI Service are grandfathered and no longer available to new customers. Moves, additions or changes to subscribers' existing service will not be permitted.

¹ ISDN-BRI is grandfathered and limited to existing customers at existing locations as of March 18, 2022. Moves, additions or changes will not be permitted. (N)

Issued by authority of an Order of the Public Service Commission of West Virginia in Case No. 22-0217-T-T dated February 25, 2022.

GENERAL SERVICES TARIFF
P.S.C.-W.Va.-No. 203

Frontier West Virginia Inc.

Section 14A
8th Revised Page 11
Cancels 7th Revised Page 11

INDIVIDUAL LINE BUSINESS DEDICATED BRI SERVICE - Grandfathered ¹

C. RATES (Cont'd)

2. Rates and Charges (Cont'd)

	Installation Charge	Per Month	
f. Featured Voice Dedicated BRI Access, per individual line	\$53.00	\$15.97	
D Channel Packet-Switched Data, per service provided.†** (LA-3) ..	14.50	4.00	
g. Multiple Access Dedicated BRI.....	36.50	33.55	(I)
(1) Each Voice service, per service provided	1.50	14.38	
(2) Circuit-Switched Data service, per service provided	1.50	14.38	
(3) Alternate Circuit-Switched Voice and Data service, per service provided	1.50	14.38	(I)
(4) D Channel Packet-Switched Data, per service provided†** (LA-3) ...	14.50	4.00	
(5) Circuit-Switched Data Usage, per minute or fraction thereof, per B channel	-	0.02	
(6) Circuit-Switched Data Usage - Volume Discount Options			
Option	Monthly Allowance		
Option 1	20 Hours per Dedicated BRI Service	10.56	
Option 2	140 Hours per Dedicated BRI Service	36.96	
Each minute, or fraction thereof, which exceeds the monthly allowance will be billed as follows:			
Option 1 - \$.008 per minute			
Option 2 - \$.004 per minute			

* Dedicated BRI rates and charges are in addition to other applicable Individual Line Business service arrangement rates and charges as specified in the appropriate Telephone Company Tariffs.
† Customers subscribing to D Channel Packet-Switched Data will be billed for Public Data Network (PDN) service as specified in the FCC No. 4 Tariff.
** Effective February 15, 2008, D Channel Packet-Switched Data service features associated with Dedicated BRI Service are grandfathered and no longer available to new customers. Moves, additions or changes to subscribers' existing service will not be permitted.
¹ ISDN-BRI is grandfathered and limited to existing customers at existing locations as of March 18, 2022. Moves, additions or changes will not be permitted.

Issued by authority of an Order of the Public Service Commission of West Virginia in Case No. 23-0266-T-T dated March 15, 2023.

GENERAL SERVICES TARIFF
P.S.C.-W.Va.-No. 203

Frontier West Virginia Inc.

Section 14A
3rd Revised Page 12
Cancels 2nd Revised Page 12

INDIVIDUAL LINE BUSINESS DEDICATED BRI SERVICE - Grandfathered ¹ (C)

C. RATES (Cont'd)

2. Rates and Charges (Cont'd)	<u>Installation Charge</u>	<u>Per Month</u>	(C)
h. Electronic Key Feature Package, per service provided	\$15.25	\$4.70	(C)
i. Packet-Switched Data Feature Package, per service provided	11.25	1.75	(C)
j. Electronic Key Features, each:			
(1) Automatic Exclusion	2.00	.25	(C)
(2) Call Pickup	2.00	.25	(C)
(3) Drop	2.00	.25	(C)
(4) Feature Function Button	2.00	.25	
(5) Hold	2.00	.25	(C)
Individual Calling Line Identification	2.00	9.35	(C)
(7) Key System Coverage for Analog Lines .	2.00	.50	(C)
(8) Multiple Call Appearances of a Directory Number	2.25	.25	(C)
(9) Outgoing Called Line Identification for ISDN Sets	2.00	.25	(C)
(10) Shared Called Appearances for a Directory Number	2.50	.50	(C)
(11) Short Hunt	2.00	.25	(C)

¹ ISDN-BRI is grandfathered and limited to existing customers at existing locations as of March 18, 2022. Moves, additions or changes will not be permitted. (N)
(N)

Issued by authority of an Order of the Public Service Commission of West Virginia in Case No. 22-0217-T-T dated February 25, 2022.

GENERAL SERVICES TARIFF
P.S.C.-W.Va.-No. 203

Frontier West Virginia Inc.

Section 14A
7th Revised Page 13
Cancels 6th Revised Page 13

INDIVIDUAL LINE BUSINESS DEDICATED BRI SERVICE - Grandfathered ¹ (C)

C. RATES (Cont'd)

2. Rates and Charges (Cont'd)

	Installation Charge	Per Month	
k. X.25 Packet Data Features** (LA-3)			
(1) Fast Select, each**	\$ 2.00	\$.25	(C)
(2) Fast Select Acceptance, each**	2.00	.25	(C)
(3) Flow Control Parameter Negotiation, each**	2.00	.25	(C)
(4) Hunt Groups, per group**	2.00	1.75	(C)
(5) Incoming Calls Barred, each**	2.00	.25	(C)
(6) Non-Standard Default Packet Sizes, each**	2.00	.25	(C)
(7) Non-Standard Default Window Sizes, each**	2.00	.25	(C)
(8) Outgoing Calls Barred, each**	2.00	.25	(C)
(9) Throughput Class Negotiation, each** .	2.00	.25	(C)
l. Virtual Office ISDN (VOI)			
(1) Month-to-Month	100.00	93.17	(C)
(2) Optional Payment Plan (OPP)			
24 months	100.00	46.00	(C)
36 months	75.00	44.00	
60 months	75.00	40.70	(C)

**Effective February 15, 2008, D Channel Packet-Switched Data service features associated with Dedicated BRI Service are grandfathered and no longer available to new customers. Moves, additions or changes to subscribers' existing service will not be permitted.

¹ ISDN-BRI is grandfathered and limited to existing customers at existing locations as of March 18, 2022. Moves, additions or changes will not be permitted. (N)

Issued by authority of an Order of the Public Service Commission of West Virginia in Case No. 22-0217-T-T dated February 25, 2022.

GENERAL SERVICES TARIFF
P.S.C.-W.Va.-No. 203

Frontier West Virginia Inc.

Section 14A-1
2nd Revised Page 1
Cancels 1st Revised Page 1

DEDICATED PRI PLUS SERVICE - BUSINESS

(C)

A. GENERAL

ISDN PRI Plus is an optional payment plan for Basic Dedicated ISDN PRI Service. This payment plan provides the option of ISDN PRI bundled with a local usage allotment. ISDN PRI Plus is a Term and Volume option for ISDN PRI customers requesting a fixed and predictable monthly rate for their complete ISDN Primary Service and associated local usage. (C)

The Dedicated PRI Plus service option includes 10,000 or 20,000 local minutes of usage, per PRI, per month. This option provides for specific usage, per Dedicated PRI, per month, plus an additional "per minute of use rate" for each minute exceeding the local minutes of usage allotment. The customer will choose the 10,000 or 20,000 local minutes of use package to meet their needs. (C)

B. REGULATIONS

1. Explanation of Terms

Termination Charges - A charge that applies when a customer terminates a service agreement prior to the expiration of the service agreement.

Usage Allotment - The quantity of usage minutes, per PRI, per month associated with the usage option selected by the customer.

2. Features

ISDN PRI Plus rates include:

- Local PRI Access Facility Mileage
- Local Usage Allowance (10,000 or 20,000 minutes)
- Calling Line Identification
- PRI DID Trunk Termination Charges

Optional Features

All ISDN Primary Service Features identified in this tariff are available to ISDN PRI Plus Subscribers at the rates, terms and conditions listed in this tariff.

When ISDN PRI Plus facilities are purchased, customers may subscribe to Caller Line ID at no additional charge. Caller Line ID with name will be available at a discounted rate, defined separately for ISDN PRI Plus subscribers.

When Customers purchase DID trunks, there is no additional charge for DID trunk terminations or DID Trunk Package (if applicable). (A separate charge for DID TN's or DID TN blocks applies consistent with rates identified elsewhere in this tariff.)

Issued by authority of an Order of the Public Service Commission of West Virginia in Case No. 11-0799-T-T dated June 21, 2011.

GENERAL SERVICES TARIFF
P.S.C.-W.Va.-No. 203

Frontier West Virginia Inc.

Section 14A-1
3rd Revised Page 2
Cancels 2nd Revised Page 2

DEDICATED PRI PLUS SERVICE - BUSINESS

(C)

3. Conditions

- a. ISDN PRI Plus is available under a 2 or 3-year Term and Volume agreement. Two-year contract customers may subscribe to three-year contract optional features or capabilities.
- b. PRI Plus will bill actual conversation time and aggregate at the Main Billing Telephone Number level.
- c. Detailed Billing is not included in the rates shown in section C. Rates and Charges. (Tariff rates, as posted in the Dedicated PRI Service Tariff, apply for Detailed Billing. (C)
- d. If the customer's actual usage exceeds the local minutes of usage allotment, included with the selected option (10,000 or 20,000 minutes of use), the customer will be charged the predetermined rate of \$.025 per minute, for each minute exceeding the allotment.
- e. If the customer uses less than the allotment of local minutes of usage per PRI, no refunds will be applied.
- f. PRI Plus rating will apply to PRI pipes specified in the PRI Plus agreement only.
- g. The minimum service period for PRI Plus is 12 months on terms plans in effect before August 14, 2009. Customers that terminate their PRI Plus service agreement prior to the 12 month minimum service period are subject to Termination Charges equal to the number of months remaining in the total 12 months multiplied by the monthly recurring rate. The minimum service period on and after August 14, 2009 is one month.
- h. Customers with an existing Dedicated PRI Plus agreement may terminate a Dedicated PRI Plus agreement and enter into a new service agreement without incurring termination liability provided the term and value of the new service agreement is greater than the remaining term and value of the existing service agreement. (C) (C)
- i. Termination Liability is 25% of the monthly rate times the remaining months in the contract.

Issued by authority of an Order of the Public Service Commission of West Virginia in Case No. 11-0799-T-T dated June 21, 2011.

Issued: June 2, 2011

Effective: July 2, 2011

GENERAL SERVICES TARIFF
P.S.C.-W.Va.-No. 203

Frontier West Virginia Inc.

Section 14A-1
1st Revised Page 2a
Cancels Original Page 2a

DEDICATED PRI PLUS SERVICE - BUSINESS

(C)

3. Conditions (Cont'd)

- j. During the life of the agreement, customers may not migrate from an ISDN PRI Plus 10,000 minutes of use option to the 20,000 minutes of use option unless the value of the new agreement is greater than or equal to the value of the existing agreement. The quantity of ISDN PRI circuits included in the new agreement must be greater than or equal to the total number of circuits included in the original agreement. The term of the new agreement must be greater than or equal to the term of the original agreement.
- k. During the life of the agreement, customers may not migrate from an ISDN PRI Plus 20,000 minutes of use option to the 10,000 minutes of use option unless the value of the new agreement is greater than or equal to the value of the existing agreement. The quantity of ISDN PRI circuits included in the new agreement must be greater than or equal to the total number of circuits included in the original agreement. The term of the new agreement must be greater than or equal to the term of the original agreement.
- l. When customers migrate from one ISDN PRI Plus option to another, all outstanding shortfall charges applicable to the existing agreement will apply.
- m. PRI Plus 10k and PRI Plus 20k pricing options are not available with Corporate Rewards, other local usage optional calling plans or customer specific pricing.

Issued by authority of an Order of the Public Service Commission of West Virginia in Case No. 11-0799-T-T dated June 21, 2011.

GENERAL SERVICES TARIFF
P.S.C.-W.Va.-No. 203

Frontier West Virginia Inc.

Section 14A-1
2nd Revised Page 3
Cancels 1st Revised Page 3

DEDICATED PRI PLUS SERVICE - BUSINESS

(C)

C. RATES AND CHARGES

	2 Years	3 Years
PRI Plus 10 Port only (PRI Interface arrangement package 1 (1-100 PRIs) w/ 10,000 local minutes of use Per PRI, per month	*	*
PRI Plus 10 Access Facility	*	*
PRI Plus 20 Interface Arrangement (1-100 PRIs) w/ 20,000 local minutes of use Per PRI, per month	*	*
PRI Plus 20 Access Facility	*	*
Optional Features		
PRI Plus Calling Line ID with Name	*	*
		Additional Usage
Each additional minute of use, per PRI		*

* Rates deregulated

Issued by authority of an Order of the Public Service Commission of West Virginia
in Case No. 11-0799-T-T dated June 21, 2011.

GENERAL SERVICES TARIFF
P.S.C.-W.Va.-No. 203

Frontier West Virginia Inc.

Section 14B
2nd Revised Page 1
Cancels 1st Revised Page 1

RESIDENTIAL DEDICATED BRI SERVICE - Grandfathered ¹

(C)

A. GENERAL

Residential Dedicated BRI Service is an optional service arrangement. Dedicated uses the Basic Rate Interface (BRI) Arrangement of the Integrated Services Digital Network (ISDN).

B. REGULATIONS

1. Explanation of Terms

Basic Rate Interface (BRI) Arrangement

Dedicated BRI Arrangement provides ISDN capabilities from an ISDN equipped switch in the central office. The BRI Arrangement consists of two "B" (Bearer) channels and one "D" channel (2B+D) which are defined as:

B Channel

The B channel is a 64 kilobit per second (kbps) channel used for information transfer between users. The B channel may be used in conjunction with circuit-switched service.

D Channel

The D channel is a 16 kilobit per second packet-switched channel that carries signaling and control for the B channels. The D channel can also be used for X.25 packet switching.

Circuit Switching

Circuit Switching is a switching technique in which an entire circuit or, in a digital switch equipped for ISDN, a specific selection of time slots is dedicated to a given call.

¹ ISDN-BRI is grandfathered and limited to existing customers at existing locations as of March 18, 2022. Moves, additions or changes will not be permitted.

(N)
(N)

GENERAL SERVICES TARIFF
P.S.C.-W.Va.-No. 203

Frontier West Virginia Inc.

Section 14B
2nd Revised Page 2
Cancels 1st Revised Page 2

RESIDENTIAL DEDICATED BRI SERVICE - Grandfathered ¹

(C)

B. REGULATIONS (Cont'd)

1. Explanation of Terms (Cont'd)

Integrated Services Digital Network

Integrated Services Digital Network (ISDN) describes the end-to-end digital telecommunications network architecture which provides for the simultaneous access, transmission and switching of voice, data and image services. These functions are provided via channelized transport facilities over a limited number of standard user-network interfaces. The ISDN architecture consists of digital switching systems which connect Basic Rate Interface lines to their serving central office.

Residential Dedicated Basic Rate Interface (BRI)

Residential Dedicated BRI is an optional service arrangement. It uses the ISDN architecture to provide the customer with the capabilities of simultaneous access, transmission and switching of voice, data and image services via channelized transport. In addition, Dedicated BRI provides the customer with the service capabilities and features described in 3. and 5. following.

Multiple Access Dedicated BRI

Multiple Access Dedicated BRI utilizes both B channels of the ISDN architecture for either voice or circuit-switched data and also applies when only one B channel is utilized for circuit-switched data or alternate voice/data.

Network Interfaces

ISDN Basic Rate Interface is comprised of a limited set of standard user-network interfaces. The BRI customer premises equipment (CPE) located at the customer premises must be compatible with the network interface. This interface is defined as follows:

A two-wire interface is the physical interface between a switch equipped with ISDN and the network termination (NT1). The NT1 is customer premises equipment which is necessary for terminating a telephone circuit or facility at the customer premises.

¹ ISDN-BRI is grandfathered and limited to existing customers at existing locations as of March 18, 2022. Moves, additions or changes will not be permitted.

(N)
(N)

Issued by authority of an Order of the Public Service Commission of West Virginia in Case No. 22-0217-T-T dated February 25, 2022.

GENERAL SERVICES TARIFF
P.S.C.-W.Va.-No. 203

Frontier West Virginia Inc.

Section 14B
2nd Revised Page 3
cancels 1st Revised Page 3

RESIDENTIAL DEDICATED BRI SERVICE - Grandfathered ¹

(C)

B. REGULATIONS (Cont'd)

1. Explanation of Terms (Cont'd)

Additional Directory Number

An ISDN Additional Directory Number (SDN) is a software defined number that is assigned to a station with an actual telephone number and provides the user the capability to originate and receive calls over the ADN. ADN calls utilize the same facilities as the primary directory number and originating calls assume the characteristics of the station to which the ADN is assigned.

2. Customers subscribing to Residential Dedicated BRI must comply with National ISDN Basic Rate Interface specifications as specified by the Telephone Company.

3. Service Capabilities

Customers can configure Residential Dedicated BRI using the following service capabilities:

- a. Featured voice on the B channel(s).
- b. Circuit-switched data on the B channel(s) at speeds up to 64 kbps per B channel.
- c. Alternating circuit-switched voice and circuit-switched data on the same B channel.

4. Conditions

This service is offered subject to the following conditions:

- a. Circuit-switched data and voice calls will be billed on a local usage-sensitive basis as specified in this tariff. Toll charges will apply when circuit-switched data and voice calls are made outside of the Local Service Area.

¹ ISDN-BRI is grandfathered and limited to existing customers at existing locations as of March 18, 2022. Moves, additions or changes will not be permitted.

(N)
(N)

GENERAL SERVICES TARIFF
P.S.C.-W.Va.-No. 203

Frontier West Virginia Inc.

Section 14B
3rd Revised Page 4
cancels 2nd Revised Page 4

RESIDENTIAL DEDICATED BRI SERVICE - Grandfathered ¹

(C)

B. REGULATIONS (Cont'd)

4. Conditions (Cont'd)

- b. ISDN compatible terminal equipment is a requirement for operation. It is the customer's responsibility to obtain and power such equipment.
- c. Residential Dedicated BRI Service is available only from central offices which have the facilities necessary to provide Residential Dedicated BRI Service on the standard ISDN network platform. If a customer is served by a central office which does not have the facilities necessary to provide Residential Dedicated BRI Service on the standard ISDN network platform, the Company may, in its discretion, provide Residential Dedicated BRI Service to the customer from an alternate serving central office, determined by the company, at no additional charge to the customer; providing such service can be provided at a reasonable cost to the Company. The customer must accept the alternate serving central office assigned by the Company, and must agree to revert service from the normal serving central office at such time as Residential Dedicated BRI Service is available from that central office.

If Residential Dedicated BRI Service is provided from an alternate serving central office, the customer must accept a telephone number associated with the alternate serving central office. The customer will also be subject to calling areas associated with the alternate serving central office as established in Company tariffs.

When Residential Dedicated BRI Service is available from the customer's normal serving central office, the customer will no longer take service from the alternate serving central office and will begin taking service from the normal serving central office and accept a telephone number change to a number associated with the normal serving central office, and the customer will be subject to calling areas associated with the normal serving central office as specified in Company tariffs. If the customer does not take service from the normal serving central office after such service becomes available but continues to take service from the alternate serving central office, charges for foreign exchange and/or foreign central office service will apply as specified in Company tariffs.

No charge will apply to transfer of this service from alternate serving central office to the normal serving central office as set forth above, or to the number changes described above.

¹ ISDN-BRI is grandfathered and limited to existing customers at existing locations as of March 18, 2022. Moves, additions or changes will not be permitted.

(N)

(N)

Issued by authority of an Order of the Public Service Commission of West Virginia in Case No. 22-0217-T-T dated February 25, 2022.

GENERAL SERVICES TARIFF
P.S.C.-W.Va.-No. 203

Frontier West Virginia Inc.

Section 14B
2nd Revised Page 5
cancels 1st Revised Page 5

RESIDENTIAL DEDICATED BRI SERVICE - Grandfathered ¹

(C)

B. REGULATIONS (Cont'd)

4. Conditions (Cont'd)

c. (Cont'd)

In addition, the customer's service location must be within the distance limitations determined during installation of the service in the sole judgment and discretion of the Company.

If a power failure occurs at the service location and the terminal equipment used by the customer does not have a battery backup, the equipment will not operate and contact with emergency services such as 911 will not be possible.

- d. Residential Dedicated BRI Service does not preclude the customer from originating circuit-switched voice calls to, or receiving circuit-switched voice calls from, inside or outside of the customer's serving central office or Local service Area. Where facilities are available, the customer will be able to originate circuit-switched data calls to, and receive circuit-switched data calls from, outside of the customer's serving central office.
- e. Residential Dedicated BRI service provides access to two circuit switched "B" channels. Single B and D packet data services are not included in this tariff offering.
- f. Residential Dedicated BRI Service will be installed only at a residence location. Residential Dedicated BRI Service will be provided on no more than three lines at a given residence location. Residential Dedicated BRI Service is not available at locations where any Business Service is provided by the Company. Use of Residential Dedicated BRI Service is not restricted to use of only residence nature. Customers subscribing to Residential Dedicated BRI Service will be provided Residence service directory listings in accordance with Company tariffs and will not be eligible for Yellow Pages listings.

¹ ISDN-BRI is grandfathered and limited to existing customers at existing locations as of March 18, 2022. Moves, additions or changes will not be permitted.

(N)
(N)

Issued by authority of an Order of the Public Service Commission of West Virginia in Case No. 22-0217-T-T dated February 25, 2022.

Frontier West Virginia Inc.

Section 14B
2nd Revised Page 6
cancels 1st Revised Page 6

RESIDENTIAL DEDICATED BRI SERVICE - Grandfathered ¹

(C)

B. REGULATIONS (Cont'd)

5. Residential Features

Residential Features provide the customer with the ability to access the following features where available. These require customer provided ISDN compatible CPE and/or software to function:

a. Automatic Exclusion

Automatically inhibits other stations from picking up a call on hold or bridging onto a call that is active at that station. This feature must be used in conjunction with Shared Call Appearances for a Directory Number.

b. Drop

Allows the user to drop the last party added to a conference call. This feature must be used in conjunction with three-way calling.

c. Feature Function Button

Allows the user to assign certain features to a particular button on the user's ISDN set. When depressed the button will activate the assigned feature.

d. Hold

Allows the user to place a call on hold.

e. Individual Calling Line Identification

Allows the user to have access to the directory number of the calling party.

f. Key System Coverage for Analog Lines

Allows an ISDN set to provide call coverage for an analog set.

g. Multiple Call Appearances of a Directory Number

Allows the user to have more than one appearance of the user's directory number assigned to the user's set, providing the capability of multiple incoming or outgoing calls associated with that directory number. Multiple incoming calls to this directory number can be terminated to the telephone if idle call appearances are available to accept the calls. Analog sets may have a total of one call appearance.

¹ ISDN-BRI is grandfathered and limited to existing customers at existing locations as of March 18, 2022. Moves, additions or changes will not be permitted.

(N)
(N)

Issued by authority of an Order of the Public Service Commission of West Virginia in Case No. 22-0217-T-T dated February 25, 2022.

GENERAL SERVICES TARIFF
P.S.C.-W.Va.-No. 203

Frontier West Virginia Inc.

Section 14B
2nd Revised Page 7
cancels 1st Revised Page 7

RESIDENTIAL DEDICATED BRI SERVICE - Grandfathered ¹

(C)

B. REGULATIONS (Cont'd)

5. Residential Features (Cont'd)

h. Outgoing Called Line Identification for ISDN Sets

Provides the user originating a call with the number of the called party.

i. Shared Call Appearances for a Directory Number

Allows a directory number from one terminal to appear as a call appearance on the terminals of other users.

j. Short Hunt

Permits incoming calls to hunt over a set of directory number appearances in search of an idle directory number on which to terminate.

¹ ISDN-BRI is grandfathered and limited to existing customers at existing locations as of March 18, 2022. Moves, additions or changes will not be permitted.

(N)
(N)

Issued by authority of an Order of the Public Service Commission of West Virginia in Case No. 22-0217-T-T dated February 25, 2022.

GENERAL SERVICES TARIFF
P.S.C.-W.Va.-No. 203

Frontier West Virginia Inc.

Section 14B
2nd Revised Page 8
cancels 1st Revised Page 8

RESIDENTIAL DEDICATED BRI SERVICE - Grandfathered ¹

(C)

C. RATES

1. Application of Rates

a. Dedicated BRI Access

(1) Service Capability Charges

(a) Monthly Rate

Monthly rates for Service. Capabilities apply per service capability provided.

(b) Installation Charge

The Installation Charge applies per termination for the installation or the move of the Dedicated BRI Access.

b. Multiple Access

- (1) Circuit-Switched data and voice local usage rates for usage in excess of "Multiple Access" package usage allowance are based on day-of-week and time-of-day use. Charges for local usage in excess of package usage allowance hours are as follows for each B channel used for data or voice:

7AM - 7PM Monday through Friday = 2 cents per minute, or fraction of a minute. All other times = 1 cent per minute, or fraction of a minute.

- (2) Multiple Access Residential Dedicated BRI packages are as follows:

Each B channel used for data or voice will be billed as follows:

7AM - 7PM Monday through Friday = 2 cents per call, per minute, or fraction of a minute. All other times = 1 cent per call, per minute, or fraction of a minute.

20 hour package includes 20 hours of single B channel voice or data usage.

60 hour package includes 60 hours of single B channel voice or data usage.

140 hour package includes 140 hours of single B channel voice or data usage.

300 hour package includes 300 hours of single B channel voice or data usage.

500 hour package includes 500 hours of single B channel for voice or data usage.

Unlimited package includes unlimited hours of two B channel voice and data usage.

¹ ISDN-BRI is grandfathered and limited to existing customers at existing locations as of March 18, 2022. Moves, additions or changes will not be permitted.

(N)
(N)

GENERAL SERVICES TARIFF
P.S.C.-W.Va.-No. 203

Frontier West Virginia Inc.

Section 14B
2nd Revised Page 9
cancels 1st Revised Page 9

RESIDENTIAL DEDICATED BRI SERVICE - Grandfathered ¹ (C)

C. RATES (Cont'd)

1. Application of Rates (Cont'd)

c. Point to Multipoint Access

A physical connection in which a single network termination supports multiple terminal equipment devices. Charges are per service profile identifier (SPID) over and above two SPIDs per termination.

2. Rates and Charges

	<u>Installation Charge</u>	<u>Per Month</u>	
Secondary Directory Number, per number established	-	\$ 3.50	(C)
b. Multiple Access Dedicated BRI*.....	\$125.00	-	(C)
20 hour package	-	31.00	(C)
60 hour package	-	45.00	
140 hour package	-	60.00	
300 hour package	-	90.00	
500 hour package	-	120.00	
Unlimited package	-	249.00	(C)
c. Residential Feature Package, per B Channel	-	4.25	(C)
d. Point to Multipoint Access.....	-	1.00	(C)

¹ ISDN-BRI is grandfathered and limited to existing customers at existing locations as of March 18, 2022. Moves, additions or changes will not be permitted. (N)

Issued by authority of an Order of the Public Service Commission of West Virginia in Case No. 22-0217-T-T dated February 25, 2022.

GENERAL SERVICES TARIFF
P.S.C.-W.Va.-No. 203

Frontier West Virginia Inc.

Section 15
Original Page 1

SWITCHED MULTI-MEGABIT DATA SERVICE

Material formerly found in this section for Switched Multi-megabit Data Service is hereby withdrawn and cancelled.

Issued by authority of an Order of the Public Service Commission of West Virginia in Case No. _____ dated _____.

Issued: January 8, 2001

Effective: January 8, 2001

GENERAL SERVICES TARIFF
P.S.C.-W.Va.-No. 203

Frontier West Virginia Inc.

Section 15A
Original Page 1

Reserved For Future Use

Issued by authority of an Order of the Public Service Commission of West Virginia
in Case No. _____ dated _____.

Issued: January 8, 2001

Effective: January 8, 2001

GENERAL SERVICES TARIFF
P.S.C.-W.Va.-No. 203

Frontier West Virginia Inc.

Section 15B
Original Page 1

FRAME RELAY SERVICE

Material formerly found in this section for Frame Relay Service is hereby
withdrawn and cancelled

Issued by authority of an Order of the Public Service Commission of West Virginia
in Case No. _____ dated _____.

Issued: January 8, 2001

Effective: January 8, 2001

CONCENTRATOR-IDENTIFIER EQUIPMENT (LA-3)

A. GENERAL

Concentrator-identifier equipment is furnished to answering bureaus as an optional arrangement to answer incoming calls.

B. REGULATIONS

1. Explanation of Terms

Concentrator Equipment

Concentrator equipment is equipment located on the Telephone Company's premises which, when used in conjunction with identifier or similar equipment located on the answering bureau's premises, enables the answering bureau to answer incoming calls for patrons at the bureau's location without the necessity of having a channel from each patron location to the bureau's location.

Identifier Equipment

Identifier equipment is equipment used in conjunction with concentrator equipment which enables the answering bureau to answer incoming calls for patrons at the bureau's location without the necessity of having a channel from each patron location to the bureau's location.

2. Provision of Service

Concentrator-identifier equipment other than electronic concentrators are available for use only with an answering switchboard, console or specifically designed for answering bureau service.

3. Electronic Concentrator Type A

- (a) The Electronic Concentrator Type A is offered under the Variable Term Payment Plan.
- (b) The term system, as used in the General Regulations Tariff pertaining to the Variable Term Payment Plan, is the electronic concentrator Type A, plus other equipment that is installed for use with the concentrator equipment arrangement.
- (c) Relocations are permitted only on a lapse-in-service basis as specified for Variable Term Payment Plan items of equipment or service in this Company's General Regulations Tariff.

Issued by authority of an Order of the Public Service Commission of West Virginia in Case No. _____ dated _____.

Frontier West Virginia Inc.

Section 16
1st Revised Page 2
Cancels Original Page 2

CONCENTRATOR-IDENTIFIER EQUIPMENT (LA-3)

B. REGULATIONS (Cont'd)

3. Electronic Concentrator Type A (Cont'd)

- (d) Conversion from Electronic Concentrator for AUTOTAS Answering System to a Electronic Concentrator Type A is permitted subject to the following conditions:

(D)

A one-time charge of \$5000.00 per primary concentrator applies.

Partial conversions of Electronic Concentrators for AUTOTAS Answering Systems will not be permitted.

- (e) Supercedures are permitted subject to a payment of a \$100.00 transfer charge.
- (f) The termination liability applicable to the electronic concentrator Type A is dependent upon the payment period selected by the customer. Termination charges for optional payment periods beyond one month are as follows:

<u>Variable Term</u> <u>Option</u>	<u>Termination Charge</u>
48 months	60% of the remaining amount due
72 months	60% of the remaining amount due

(g) Application of System Activity Charges

- (1) A System Charge applies for the initial establishment of a electronic concentrator Type A, and for subsequent equipment additions on a per order basis.
- (2) Unit Charges apply for each item of equipment added to an arrangement subsequent to the initial installation of such arrangement.

Issued by authority of an Order of the Public Service Commission of West Virginia in Case No. _____ dated _____.

CONCENTRATOR-IDENTIFIER EQUIPMENT (LA-3)

B. REGULATIONS (Cont'd)

4. System Activity Charges

System Activity Charges specified in this section apply as follows:

Equipment and Feature Package Addition Charges

Equipment and Feature Package Addition Charges apply when Electronic Concentrator Line Cards, and Patron Line Control are added to an Electronic Concentrator for AUTOTAS# Answering System subsequent to its initial installation.

C. RATES

1. Concentrator-identifier Equipment

a. Other than electronic concentrators	Per Month	Termination Charge	USOC
--	--------------	-----------------------	------

Each system equipped for connecting 100 or less lines which are served by the same wire center in which the concentrator is located*, each (LA-3).....	\$185.57	\$1056.42 (60)	ST3
--	----------	----------------	-----

b. Electronic Concentrator for AUTOTAS Answering System

(1) System Activity Charges Electronic Concentrators for AUTOTAS Answering System

Equipment and Feature Addition Charges

(a) System Charges, each occasion†, for adding equipment in a central office, per central office

Service Mark of Candela Electronics, Inc.

* In addition, a monthly rate equal to the applicable rate for 15 answering connections applies, as specified in the Channel Services Tariff, Section 3, when the answering bureau and the patron are not located on the same premises. For each answering connections connected in the system, the preceding number of 15 is reduced by one.

† When more than one category is added at the same time only one System Activity Charge applies, such charge being the System Activity Charge applicable to the lowest numbered category being used.

Issued by authority of an Order of the Public Service Commission of West Virginia in Case No. _____ dated _____.

Issued: January 8, 2001

Effective: January 8, 2001

GENERAL SERVICES TARIFF
P.S.C.-W.Va.-No. 203

Frontier West Virginia Inc.

Section 16
Original Page 4

CONCENTRATOR-IDENTIFIER EQUIPMENT (LA-3)

C. RATES (Cont'd)

1. Concentrator-identifier Equipment (Cont'd)

(1) System Activity Charges Electronic Concentrators for AUTOTAS Answering System (Cont'd)

(a) (Cont'd)	Per Month	Termination Charge	USOC
I. Category I - For adding Secondary Electronic Concentrator.....			\$1084.36
II. Category II - For adding Electronic Concentrator Line Cards or Patron Line Control Unit.....			\$335.37

(b) Unit charges, per equipment added, each

I. Group E - Secondary Electronic Concentrator	\$162.10
II. Group F - Electronic Concentrator Line Card	\$106.20
III. Group G - Patron Line Control Unit	\$11.18

(2) Electronic Concentrators for AUTOTAS Answering System, capacity of 256 patron Telephone service line connections†, each

	<u>Installation Charge</u>	<u>Per Month</u>	<u>USOC</u>
Primary	\$6277.01	\$369.02	HXJ
Secondary, maximum of two per primary Electronic Concentrator	1973.09	105.81	HXN
Line Cards, per 32 patron Telephone service line connections or fraction thereof, each	61.48	39.57	HXL
Patron Line Control Unit, per 25 connections or fraction there of	201.22	28.45	HXQ

† When more than one category is added at the same time only one System Activity Charge applies, such charge being the System Activity Charge applicable to the lowest numbered category being used.

Issued by authority of an Order of the Public Service Commission of West Virginia in Case No. _____ dated _____.

Issued: January 8, 2001

Effective: January 8, 2001

GENERAL SERVICES TARIFF
P.S.C.-W.Va.-No. 203

Frontier West Virginia Inc.

Section 16
Original Page 5

CONCENTRATOR-IDENTIFIER EQUIPMENT (LA-3)

C. RATES (Cont'd)

1. Concentrator-identifier Equipment (Cont'd)

c. Electronic Concentrator, Type A, for use with Various Answering Systems

(1) System Activity Charges

(a) System charge, per order \$550.00

(b) Unit charges, per item, each addition

Concentrator line card..... 225.00

Patron line control..... 60.00

Secondary concentrator..... 1400.00

(2) Concentrators, capacity of 256 patron telephone service line connections and 16* channels, and including the variable ring count feature†, each

	Installation Charge #	Optional Variable Terms			USOC
		1 Month	48 Months	72 Months	
(a) Primary, maximum of one per arrangement ..	\$7500.00	\$655.00	\$560.00	\$475.00	ECR
(b) Secondary, maximum of two per arrangement ..	2205.00	210.00	185.00	160.00	ECV
(3) Line Cards, per 32 patron telephone service line telephone service line thereof, each	48.00	67.00	58.00	48.00	EC2

* A maximum of 16 channels provided to primary only.

† When utilized, the variable ring count feature requires a Series 3000, type 002, Channel at rates and charges as specified in this Company's Channel Services Tariff, Section 4 between the concentrator location and the customer premises location and also requires a Combined Sending and Receiving Data Set capable of conditioning signals at rates up to 300 bits per second at the concentrator location and at the customer-premises locations.

Not applicable to conversions from Electronic Concentrators for AUTOTAS Answering System.

Issued by authority of an Order of the Public Service Commission of West Virginia in Case No. _____ dated _____.

GENERAL SERVICES TARIFF
P.S.C.-W.Va.-No. 203

Frontier West Virginia Inc.

Section 16
Original Page 6

CONCENTRATOR-IDENTIFIER EQUIPMENT (LA-3)

C. RATES (Cont'd)

1. Concentrator-identifier Equipment (Cont'd)

c. Electronic Concentrator, Type A, for use with Various Answering Systems (Cont'd)

	<u>Installation Charge*</u>	<u>Optional Variable Terms</u>			<u>USOC</u>
		<u>Per Month</u>			
		<u>1 Month</u>	<u>48 Months</u>	<u>72 Months</u>	
(4) Patron Line Control, per 25 connections or fraction thereof, each	\$150.00	\$42.00	\$35.00	\$30.00	EC7

2. Connections to Concentrators

a. Where the patron is served from the wire center in which the concentrator is located, each

	<u>Installation Charge</u>	<u>Per Month</u>	<u>USOC</u>
(1) Other than electronic concentrator connections	-	\$11.01	ST2
(2) Electronic concentrator connections ..	\$17.61	-	BC3

b. Where the patron is not served from the wire center in which the concentrator equipment is located, Channel Services channels are required.

(U)

* Not applicable to conversions from Electronic Concentrators for AUTOTAS Answering System.

Issued by authority of an Order of the Public Service Commission of West Virginia in Case No. _____ dated _____.

Issued: January 8, 2001

Effective: January 8, 2001

GENERAL SERVICES TARIFF
P.S.C.-W.Va.-No. 203

Frontier West Virginia Inc.

Section 17
Original Page 1

Reserved For Future Use

Issued by authority of an Order of the Public Service Commission of West Virginia
in Case No. _____ dated _____.

Issued: January 8, 2001

Effective: January 8, 2001

TIME OF DAY SERVICE

A. GENERAL

Time of Day Service provides for the furnishing of time of day information by the Telephone Company through use of exchange telephone service.

B. REGULATIONS

1. This service is furnished for the convenience and accommodation of telephone users and the Telephone Company assumes no liability in connection therewith.
2. The Telephone Company will continue to provide Time of Day Service as a public service after January 1, 1983 subject to the following conditions:
 - a. These announcements were provided by the Telephone Company prior to July 18, 1980,
 - b. no sponsors are able to provide these announcements, and
 - c. there are no special charges to the caller other than the applicable measured charges for the call as placed.
3. Once a sponsor has provided Time of Day Service after January 1, 1983 and the Telephone Company has withdrawn the offering, the Telephone Company will no longer provide Time of Day Service as a Public offering.

C. RATES

Each call for time of day information is subject to the same regulations and measured charges applicable for other calls originating from the calling station.

Issued by authority of an Order of the Public Service Commission of West Virginia in Case No. _____ dated _____.

GENERAL SERVICES TARIFF
P.S.C.-W.Va.-No. 203

Frontier West Virginia Inc.

Section 19
1st Revised Page 1
Cancels Original Page 1

LOCAL CONFERENCE SERVICE

A. GENERAL

Local Conference Service is a connection among three or more exchange service lines including branch exchange trunks and Centrex lines or any combination thereof, all of which are within the same exchange area, on one connection at the same time. All such lines and trunks are so interconnected that each may communicate with all others.

B. REGULATIONS

1. Local Conference Service shall be established only by a Telephone Company operator utilizing conference equipment located in the Telephone Company central office.
2. This service is furnished only in exchanges within the local service area of an exchange where the equipment required for Local Conference Service is available.
3. Local Conference Service calls may be established on either a person-to-person or station-to-station basis, the same rate applying in either case.
4. The Telephone Company will, at the request of a customer, undertake to arrange for the establishment of a local conference connection at a specified time.
5. Charges for Local Conference Service calls are billed in total only and may be billed to the originating line or a called line. (C)
6. Chargeable time begins when connection is established among all the specified persons, lines or trunks and ends on a given two-point connection of a conference call when the connection is terminated by the originating line or the called line.

C. RATES

The rate for a conference connection is the sum of:	Initial Period 1 Minute or Fraction Thereof	Add'l Period Each Minute or Fraction Thereof
---	---	--

- | | | |
|--|-------|-------|
| 1. A charge of \$4.00 for each called line, branch exchange trunk or centrex line, and | | |
| 2. Each line or branch exchange trunk in excess of the originating line..... | \$.22 | \$.10 |

* Effective July 1, 2010 Frontier West Virginia Inc. Calling Cards will be discontinued and will not be accepted as a billing arrangement for calls. (N)
(N)

Issued by authority of an Order of the Public Service Commission of West Virginia in Case No. _____ dated _____.

GENERAL SERVICES TARIFF
P.S.C.-W.Va.-No. 203

Frontier West Virginia Inc.

Section 20
1st Revised Page 1
Cancels Original Page 1

OPERATOR ASSISTED LOCAL CALLS

A. GENERAL

Operator Assisted Local Calls are calls placed within the customer's local service area or to a Directory Assistance Service operator through a Telephone Company operator.

B. REGULATIONS

1. Explanation of Terms

Bill to Third Party

Bill to third party denotes a billing arrangement by which a call may be charged to an authorized line as determined by the Telephone Company other than the line originating the call or the line where the call is connected.

(D)
|
(D)

Coin Telephone

A public telephone which is located for use by the general public. Sent-paid calls, from a coin phone, require a deposit for the rates in effect for the call.

Collect Call

Collect call denotes a billing arrangement by which the charge for a call may be reversed provided the charge is accepted at the called line. A collect call may be billed to a or third party number. In case of calls to coin telephones the charges must be billed to a third party number, or the call may be reoriginated from the called line.

(C)
(C)

Noncoin Telephone

A station other than a coin telephone and not intended for use by the general public.

* Effective July 1, 2010 Frontier West Virginia Inc. Calling Cards will be discontinued and will not be accepted as a billing arrangement for calls. (N)
(N)

Issued by authority of an Order of the Public Service Commission of West Virginia in Case No. _____ dated _____.

Issued: June 2, 2010

Effective: July 1, 2010

GENERAL SERVICES TARIFF
P.S.C.-W.Va.-No. 203

Frontier West Virginia Inc.

Section 20
1st Revised Page 2
Cancels Original Page 2

OPERATOR ASSISTED LOCAL CALLS

B. REGULATIONS (Cont'd)

1. Explanation of Terms (Cont'd)

Sent-paid Call

A sent-paid call is a call that is charged to the originating station.

2. The local message charge for calls placed from a Pay Telephone Network Line will be the same as for a local call dialed direct by the customer. The local message charge for calls placed from all other services will be the same as specified in the Local Exchange Services Tariff for applicable Measured Usage Charges, from a Residence Service.
3. Local message charges may be transferred, i.e., billed to the line called, or billed to a line other than the calling line or called line, except that such message charges will not be billed to a Pay Telephone Network Line or Service for Customer-provided Coin and Credit Card Operated Telephones.
4. Charges for local messages transferred to measured rate service will not affect the normal usage charges allowance applicable to such services.
5. Exceptions
 - a. Calls to Telephone Company listed official public emergency agencies.
 - b. Calls to official Telephone Company numbers.
 - c. Sent-paid calls from persons experiencing dialing difficulty.
 - d. Sent-paid calls from persons who are visually and/or physically disabled will be exempted by means of the completion of a self-certification form supplied by the Telephone Company.

(D)

(D)

* Effective July 1, 2010 Frontier West Virginia Inc. Calling Cards will be discontinued and will not be accepted as a billing arrangement for calls.

(N)

(N)

Issued by authority of an Order of the Public Service Commission of West Virginia in Case No. _____ dated _____.

Issued: June 2, 2010

Effective: July 1, 2010

Frontier West Virginia Inc.

Section 20
1st Revised Page 3
Cancels Original Page 3

OPERATOR ASSISTED LOCAL CALLS

C. RATES

1. Rate Schedule

The following charges apply for operator assisted local calls and are in addition to any charges for local messages or Directory Assistance Service calls as specified in this Company's applicable tariffs.

a. Station-to-station

(D)
|
(D)

(1) Operator Assisted

Operator assisted service requires the services of a Telephone Company operator in the completion of station-to-station calls or requests for any information or assistance relating to billing or charges for such calls, except as specified preceding for customer-dialed calls.

An operator assisted call may be either operator completed or operator serviced.

(a) An operator completed call is a call which the customer dials as zero, and the operator dials the called number, obtains the billing information and/or completes the call. This call is referred to as zero minus (0-) indicating that the caller needs to dial 0. An operator assisted charge applies.

(b) An operator serviced call is a call which the customer dials as zero, plus the called number, and requires the assistance of the operator for billing and completion. This call is referred to as zero plus (0+) indicating that the caller needs to dial 0, followed by the called number. An operator assisted charge applies.

Charge Per
Call

Operator Completed (0-), coin or noncoin \$2.00
(Operator dials the number)

* Effective July 1, 2010 Frontier West Virginia Inc. Calling Cards will be discontinued and will not be accepted as a billing arrangement for calls. (N)
(N)

Issued by authority of an Order of the Public Service Commission of West Virginia in Case No. _____ dated _____.

GENERAL SERVICES TARIFF
P.S.C.-W.Va.-No. 203

Frontier West Virginia Inc.

Section 20
2nd Revised Page 4
Cancels 1st Revised Page 4

OPERATOR ASSISTED LOCAL CALLS

C. RATES (Cont'd)

1. Rate Schedule (Cont'd)

a. Station-to-station (Cont'd)

(1) Operator Assisted (Cont'd)

	Charge Per Call	
Operator Serviced (0+) (Customer dials the number)		
Coin or Collect	\$2.00	
All Others	1.55	
Corrections Collect Call60	(D)
b. Person-to-person.....	4.00	
c. Directory Assistance Service		(D)
All Other Calls	1.55	(D) (D)

* Effective July 1, 2010 Frontier West Virginia Inc. Calling Cards will be discontinued and will not be accepted as a billing arrangement for calls. (N)
(N)

Issued by authority of an Order of the Public Service Commission of West Virginia
in Case No. _____ dated _____.

OPERATOR ASSISTED LOCAL CALLS

D. LIVE OPERATOR FEE

(N)

In addition to other operator service charges set forth in this section, a live operator fee is applied when the customer chooses to speak with a live operator. The customer is informed by the automated system of the applicable charges prior to connection to the operator. The charge will be collected at the time of payment processing.

This fee will not apply if:

- The automated payment systems are unavailable due to system outages.
- Customer is requesting a call to an emergency service.
- Call cannot be made by the automated system.

Rates

	<u>Nonrecurring Charge</u>
Live Operator Fee, per occurrence	\$1.50

(N)

Issued by authority of an Order of the Public Service Commission of West Virginia in Case No. 19-1040-T-T dated October 31, 2019.

GENERAL SERVICES TARIFF
P.S.C.-W.Va.-No. 203

Frontier West Virginia Inc.

Section 20A
1st Revised Page 1
Cancels Original Page 1

(RESERVED FOR FUTURE USE)

(C)

(O)

(O)

Issued by authority of an Order of the Public Service Commission of West Virginia
in Case No. 18-0080-T-T dated February 8, 2018.

Issued: January 31, 2018

Effective: March 2, 2018

CUSTOM CALLING SERVICES

A. GENERAL

Custom Calling Services consist of optional service features for use in connection with a customer's exchange service excluding Centrex Services.

B. REGULATIONS

1. Explanation of Terms

Activation

Activation is the means by which certain Custom Calling Services features are initiated. This activation requires dialing a code, which is followed by an announcement confirming execution. Three-way Calling does not require a code on a per activation basis.

Anonymous Call Rejection

Anonymous Call Rejection is an arrangement that allows a called party to reject calls from parties that have per line Number/Name Display Prevention or have activated the *67 per call blocking feature to prevent the display of the calling telephone numbers to Caller ID - Number Only subscribers or to prevent the display of the calling telephone numbers and associated main listed names to Caller ID subscribers. When Anonymous Call Rejection is activated, such calls will be routed to an announcement which tells the calling party that the called party will not accept calls from callers who have chosen to prevent the display of their telephone numbers and names. The calling party will be instructed to hang up and place the call again by unblocking the per line Number/Name Display Prevention or without activating the *67 per call blocking feature. Customers may activate or deactivate Anonymous Call Rejection by dialing an activation code. This arrangement is included with the Caller ID - Number Only and Caller ID Services.

Selective Call Rejection

(C)

Selective Call Rejection is an arrangement which prevents future calls from up to six prespecified telephone numbers, one of which may be the most recent incoming call from an unknown telephone number immediately after the unwanted call has been received. Callers from the prespecified telephone numbers will receive an announcement that the called party is not accepting calls. For calls from a line within a multiline hunting group, the call will be blocked only when the main telephone number is included as one of the six prespecified telephone numbers.

Issued by authority of an Order of the Public Service Commission of West Virginia in Case No. 14-1140-T-T dated July 8, 2014.

GENERAL SERVICES TARIFF
P.S.C.-W.Va.-No. 203

Frontier West Virginia Inc.

Section 21
3rd Revised Page 1a
Cancels 2nd Revised Page 1a

CUSTOM CALLING SERVICES

B. REGULATIONS (Cont'd)

1. Explanation of Terms (Cont'd)

Call Forwarding

Call forwarding is an arrangement whereby incoming calls may be transferred to another telephone number by dialing a prefix code and the telephone number of the service to which calls are to be transferred. Calls forwarded by this feature are subject to local and long distance message charges. This service contemplates that normal transmission performance quality cannot be guaranteed to all calls.

(0)

(0)

Call Trace

Call trace is an arrangement which permits the customer to trace the last call received. The result of the call trace is automatically sent to the Telephone Company for subsequent furnishing to legally constituted law enforcement agencies or authorities upon proper request by them. The call trace result is not available to the customer. The Telephone Company is not liable for damages if, for any reason, the call trace attempt is not successful.

Issued by authority of an Order of the Public Service Commission of West Virginia in Case No. 12-0583-T-T dated May 21, 2012.

Issued: May 2, 2012

Effective: June 1, 2012

CUSTOM CALLING SERVICES

B. REGULATIONS (Cont'd)

1. Explanation of Terms (Cont'd)

Call Waiting

Call Waiting is an arrangement whereby a customer who is using an exchange line arranged for call waiting is alerted, by means of a tone signal, when another caller is trying to reach that line. The customer, by flashing the switchhook, is able to have alternate conversation between parties. Where facilities permit, the incoming call tone signal may be blocked on a per-call basis. At the completion of the call, the call waiting feature is automatically reactivated.

Caller ID - Number Only ¹

(C)

Caller ID - Number Only is an arrangement which permits a customer with Local Exchange Service other than foreign exchange, foreign zone or foreign central office service to receive the calling telephone number for non-blocked calls placed to the customer. The calling telephone number will be forwarded from the terminating central office to compatible customer-provided display equipment associated with a customer's Local Exchange Service, subject to technical and other limitations including the availability of the number for forwarding. The calling telephone number typically will be delivered by the second ring. For calls originating from a line within a multiline hunting group, only the main telephone number will be delivered. If the calling telephone number is not available for forwarding to the called party, a message indicating that unavailability will be forwarded. The calling party can prevent the Caller ID - Number Only customer from seeing the calling telephone number display by blocking caller identification information. When the calling party uses this blocking capability, the Caller ID - Number Only customer will receive an indication on the Caller ID - Number Only equipment that the display of the calling telephone number has been suppressed. There is no charge for using Per Call Blocking. Caller ID - Number Only customers may re-direct to an announcement, incoming calls with Per Call Blocking activated, by activating the Anonymous Call Rejection arrangement. Where facilities permit and where a subscriber with Call Waiting chooses Call Waiting ID Deluxe, the calling name and number display when Call Waiting is activated.

¹ Effective July 20, 2014, this service is limited to existing customers at their existing location.

(N)
(N)

Issued by authority of an Order of the Public Service Commission of West Virginia in Case No. 14-1140-T-T dated July 8, 2014.

CUSTOM CALLING SERVICES

B. REGULATIONS (Cont'd)

1. Explanation of Terms (Cont'd)

Caller ID

Caller ID is an arrangement which permits a customer with Local Exchange Service, other than foreign exchange, foreign zone or foreign central office services provisioned over interoffice facilities, to receive the calling telephone number and the main listed name associated with the calling telephone number for non-blocked calls placed to the customer. The calling telephone number and name will be forwarded (typically by the second ring) from the terminating central office to compatible customer-provided display equipment associated with a customer's Local Exchange Service, subject to limitations such as those described below. For calls originating from a line within a multiline hunting group, only the main telephone number and name will be delivered. The name and telephone number of the caller may not be displayed for every incoming call. "Out of Area," "Unavailable," the calling party's state name, or a similar message may appear for certain calls, including (i) calls made through certain networks, (ii) operator-assisted calls, calls from toll-free numbers, calling card calls, and international calls, (iii) when phone number or caller name information is not made available to Verizon, (iv) for certain telephone numbers for which Frontier does not purchase Caller ID information, and (v) for other technical reasons. In addition, "Private," "Anonymous" or a similar message may appear when the caller has blocked caller identification information. There is no charge for using Per Call Blocking. Caller ID customers may re-direct to an announcement, incoming calls with Per Call Blocking activated, by activating the Anonymous Call Rejection arrangement.

Dependent Number

A Dependent Number is an additional telephone number, serving off a Distinctive Ring master number, which allows for incoming calls only. The origination of calls from this number is not permitted. The dependent number will be the same class of service as the associated master number.

Home Intercom ¹

(C)

Home Intercom is a feature which provides intercommunication (intercom) capability on individual lines, and which utilizes distinctive ringing to distinguish intercom calls from incoming exchange calls. Home Intercom is activated by dialing the associated telephone number. No measured service charges will apply for these calls.

¹ Effective July 20, 2014, this service is limited to existing customers at their existing location. (N)
(N)

Issued by authority of an Order of the Public Service Commission of West Virginia in Case No. 14-1140-T-T dated July 8, 2014.

CUSTOM CALLING SERVICES

B. REGULATIONS (Cont'd)

1. Explanation of Terms (Cont'd)

Distinctive Ring

Distinctive Ring is a feature which allows a customer to have up to three separate telephone numbers assigned to one local exchange line. Each telephone number will provide a distinctive ring on incoming calls to allow for identification of the incoming call. A distinctive call waiting tone for each telephone number will be provided, where facilities permit, to customers also subscribing to call waiting.

Home Phone Transfer to Intercom Feature ¹ (C)

The Home Phone Transfer to Intercom feature is a feature which provides intercom capability and which utilizes distinctive ringing to distinguish intercom calls from incoming exchange calls. No measured service charges will apply for these calls. The Home Phone Transfer to Intercom feature includes the following other features.

Call Hold ¹ (C)

Call Hold is an arrangement which permits an established call to be placed on hold in order to continue a conversation from another extension on the line.

Intercom Code Dialing ¹ (C)

Intercom Code Dialing is an arrangement that allows activation of intercom calls by dialing an access code.

Selective Call Transfer ¹ (C)

Selective Call Transfer is an arrangement whereby an access code may be dialed to activate a distinctive ringing pattern to alert other extensions on the line to join an established call.

Three-way Calling

Same as specified for Three-way Calling in this section.

¹ Effective July 20, 2014, this service is limited to existing customers at their existing location. (N)
(N)

CUSTOM CALLING SERVICES

B. REGULATIONS (Cont'd)

1. Explanation of Terms (Cont'd)

Master Number

A Master Number is the Local Exchange Service telephone number equipped with Distinctive Ring.

Number/Name Display Prevention

Caller ID - Number Only Service and Caller ID Service, as set forth in Section 21 of this Tariff, allow a subscriber to see the calling telephone number or the calling telephone number and the name associated with the calling telephone number on non-blocked calls placed to the subscriber subject to limitations such as those described below. These services forward the calling party's telephone number to the terminating central office, where facilities permit, and then to a customer-provided display unit attached to the customer's telephone. They employ a dedicated signaling network between central offices which will forward the calling number identification information. In addition, Caller ID provides the main listed name associated with the telephone number. These services work only on calls that originate from and terminate in central offices that are connected by this dedicated signaling network. The name and telephone number of the caller may not be displayed for every incoming call. "Out of Area," "Unavailable," the calling party's state name, or a similar message may appear for certain calls, including (i) calls made through certain networks, (ii) operator-assisted calls, calls from toll-free numbers, calling card calls, and international calls, (iii) when phone number or caller name information is not made available to Verizon, (iv) for certain telephone numbers for which Frontier does not purchase Caller ID information, and (v) for other technical reasons. In addition, "Private," "Anonymous" or a similar message may appear when the caller has blocked caller identification information.

Upon request, victims of domestic violence protected by a court order, victim's service programs, battered women's shelters or other organizations providing safe haven for victims of domestic violence will be provided with the capability to automatically prevent the display of the calling telephone number and name for all calls originating from their lines, at no charge. In addition, law enforcement or other governmental entities will be provided with such capability, also at no charge, upon demonstration of a special need for anonymity to the satisfaction of the Telephone Company. Further, such capability will be provided to non-published customers upon request, at rates and charges specified following and elsewhere in the applicable Telephone Company tariffs. With this blocking feature, the Caller ID - Number Only/Caller ID subscriber will receive an indication on the display unit that the calling telephone number and name have been suppressed. Calling parties whose lines are equipped with this feature will have the option of permitting display of the calling telephone number and name by dialing a special code prior to placing each call. There is no charge for turning the feature off on a per-call basis.

Frontier West Virginia Inc.

Section 21
5th Revised Page 4a
Cancels 4th Revised Page 4a

CUSTOM CALLING SERVICES

B. REGULATIONS (Cont'd)

1. Explanation of Terms (Cont'd)

Per Call Blocking

Per Call Blocking is an arrangement which blocks the name and number of the calling party from being transmitted to Caller ID - Number Only or Caller ID display units for the next call placed.

Priority Call

Priority Call is an arrangement which provides for one distinctive audible signal to the customer when a call is received from one of up to six prespecified telephone numbers. If the customer also subscribes to Call Waiting, and the incoming call arrives while the line is busy, the usual call waiting tone is altered with a distinctive pattern. For calls originating from a line within a multiline hunting group, the distinctive signal is only produced when the caller's main telephone number is one of those prespecified.

Busy Number Redial

(C)

Busy Number Redial is an arrangement which permits the customer to redial automatically the last number dialed. If the called line is found to be busy, a 30-minute queuing process begins. The customer is then given an indication that the network will attempt to set up the call when called line is idle. The network periodically tests the busy/idle status of the called line until both lines are found idle or the queuing process expires. (C)

Residence Packages

Residence Packages are combinations of two or more specified Custom Calling Service features, excluding Caller ID - Number Only, Caller ID, and Fixed Call Forwarding offered at a rate as specified in C. following, to residence customers only.

GENERAL SERVICES TARIFF
P.S.C.-W.Va.-No. 203

Frontier West Virginia Inc.

Section 21
2nd Revised Page 5
Cancels 1st Revised Page 5

CUSTOM CALLING SERVICES

B. REGULATIONS (Cont'd)

1. Explanation of Terms (Cont'd)

Residence Call Manager Package

The Residence Call Manager Package is a discounted billing arrangement which includes three individual features: Caller ID, Call Waiting, and Fixed Call Forwarding. The customer must subscribe to all three features in order to qualify for the package rate. If the customer chooses to disconnect one of the features, the discount rate no longer applies and the individual rate, as specified in this tariff, then applies to the feature(s) remaining in service. (C)

Issued by authority of an Order of the Public Service Commission of West Virginia in
Case No _____ Dated _____.

Issued: May 10, 2002

Effective: June 10, 2002

CUSTOM CALLING SERVICES

B. REGULATIONS (Cont'd)

1. Explanation of Terms (Cont'd)

Selective Call Forwarding

(C)

Selective Call Forwarding is an arrangement which permits a customer to prespecify, up to a maximum of six, telephone numbers from which calls are to be forwarded. During the period that select forward is activated, only calls from one of the prespecified numbers will be forwarded. For calls from a line within a multiline hunting group, the call will be forwarded only when the main telephone number has been prespecified.

(C)

Call Return (*69)

(C)

Call Return (*69) allows a customer to obtain information about the last incoming call when the service is activated by dialing *69. Upon dialing *69, the telephone number associated with the last incoming call is announced if it is available from the network and the calling party has not blocked the calling information. Depending on the serving central office, the date and time of the call may also be announced. The announced telephone number does not always identify the calling party and, in some cases, cannot be used to return the call automatically or by manual dial back.

(C)

If possible, the service may also allow a customer to return the call automatically by dialing "1". *69 cannot return all calls for which it can announce a number. When a telephone number is announced, the customer is instructed to dial "1" to return the call automatically. If the customer dials "1" and the line associated with the called number is busy, the call is queued for up to 30 minutes or until both lines are idle. When both lines are idle, the customer is given an indication with a distinctive ringing pattern that the network will attempt to set up the call. Once the customer answers the distinctive ring, the network attempts to set up the call.

For purposes of calculating the discount to be applied to the Residence Package, prior to February 3, 1999, the Big Deal will count as one eligible feature; thereafter, the Big Deal will count as four eligible features.

Issued by authority of an Order of the Public Service Commission of West Virginia in Case No. 14-1140-T-T dated July 8, 2014.

CUSTOM CALLING SERVICES

B. REGULATIONS (Cont'd)

1. Explanation of Terms (Cont'd)

Speed Dialing

Speed Dialing is an arrangement which provides for the calling of a telecommunications network telephone number by dialing an abbreviated code. Two arrangements are available, an eight-code capacity¹ and/or a thirty-code capacity. (C)

The Big Deal¹ (C)

The Big Deal is a discounted billing arrangement for residence customers that allows customers to select as many features as they wish from the following list: Anonymous Call Rejection, Call Block, Call Forwarding-Busy Line Don't Answer, Call Waiting, Distinctive Ring, Fixed Call Forwarding, Home Phone Transfer to Intercom, Busy Redial, *69, Speed Dialing and Three-way Calling, Caller ID is automatically included in the Big Deal. Customers must presubscribe to the Telephone Company as their local exchange provider to be eligible for the Big Deal. Customers subscribing to the Big Deal are not eligible for the Residence Call Manager Package or any other Custom Calling Services package, unless otherwise explicitly stated*. Custom Calling features not included in the Big Deal, but otherwise eligible for Residence Feature Package discounts, will receive a discount of 35% off tariffed rates when purchased in conjunction with the Big Deal.

Three-way Calling

Three-way Calling permits an existing call to be held and a second call to be established and added to the connection for conferencing. This service contemplates that normal transmission performance quality cannot be guaranteed to all calls.

Features Plan - Business provides business customers with an option of receiving discounts by subscribing to one of seven feature packages depending upon their business and telecommunication needs.

¹ Effective July 20, 2014, this service is limited to existing customers at their existing location. (N)
(N)

CUSTOM CALLING SERVICES

B. REGULATIONS (Cont'd)

1. Explanation of Terms (Cont'd)

Selective Call Acceptance

(N)

Selective Call Acceptance screens incoming calls and only allows access to those telephone numbers on a customer determined list (up to a maximum of 12 telephone numbers). All others will be directed to a pre-recorded message.

Multiple Simultaneous Call Forward

Multipath Simultaneous Call Forward - This feature provides a business customer with the capability to specify the number of calling paths that will be forwarded from one subscriber line to another telephone number. The feature is offered where facilities permit and at no time will this service take precedent over the requirement for these facilities to provide a customer with telephone service. Multiple Simultaneous Call Forward is restricted to voice use only. The feature is available only as an enhancement to one or more of the following features: Call Forwarding, Call Forward Busy and Call Forward No Answer. Multiple Simultaneous Call Forward is limited to ten (10) call forwarding paths per telephone number. It can be used with any of the following services: Bl, PBX, Centrex and ISDN BRI.

(N)

CUSTOM CALLING SERVICES

B. REGULATIONS (Cont'd)

2. All Custom Calling Services may be associated with individual line service. In addition the Call Forwarding and Fixed Call Forwarding features may be associated with Private Branch Exchange (PBX) trunks excluding those trunks with which Direct Inward Dialing (DID) Service is associated. Custom Calling Services are only available to customers served by compatible electronic type switching equipment. Certain Custom Calling Service features require that calls to the customer originate from central offices equipped by compatible electronic type switching equipment.

Custom Local Area Signaling Service features are applicable to calls placed to/from compatible central offices or within a compatible central office offering the service. These services are offered based on information stored within the switch or provided to the switch through call setup signaling and are subject to limitations associated with the availability and content of that information. Services which require this signaling are: Anonymous Call Rejection, Call Block, Call Trace, Caller ID - Number Only, (O) Caller ID, Priority Call, Busy Redial, Select Call Forwarding and *69.

3. Distinctive Ring

Distinctive Ring can be provided with other Custom Calling Service features. Custom Calling Service features are provided in association with the master number only; however, any Custom Calling Service feature associated with a master number is automatically available to the associated dependent numbers, except as specified following.

- b. The Call Forwarding feature is available in one of two arrangements. When the Call Forwarding feature is activated:
 - (1) Calls to the master and dependent numbers are forwarded to the same location; or,
 - (2) Only calls to the master number will be forwarded. Calls to the dependent numbers will not be forwarded.
- c. Distinctive Ring can only be utilized through the use of compatible customer-provided terminal equipment.

CUSTOM CALLING SERVICES

B. REGULATIONS (Cont'd)

3. Distinctive Ring (Cont'd)

- d. Distinctive Ring is not provided in association with lines equipped with hunting arrangements except on the last line in a group of lines arranged for series completion hunting, provided such a line has no further hunting or other special translations data entered against it and is served from a central office capable of providing this service.

Issued by authority of an Order of the Public Service Commission of West Virginia
in Case No. _____ dated _____.

Frontier West Virginia Inc.

Section 21
2nd Revised Page 9
Cancels 1st Revised Page 9

CUSTOM CALLING SERVICES

B. REGULATIONS (Cont'd)

4. The Custom Calling Service features of Call Block, Call Trace, Caller ID - Number Only, Caller ID, Priority Call, Busy Redial, Select Call Forwarding, and *69 are not available on the same Local Exchange Service line. In addition, Priority Call cannot be offered with the Distinctive Ring second distinctive ringing pattern.
5. Home Intercom
 - a. Home Intercom is offered only on residence lines, and each such line must have at least two fully operational telephones.
 - b. Home Intercom can be provided with other custom calling features, however, the Three-way Calling and Call Waiting features are disabled for the duration of an intercom call. In addition, in certain areas, Home Intercom cannot be accessed when a Call Forwarding feature is activated.
 - c. Home Intercom can only be utilized through the use of compatible customer-provided terminal equipment.
 - d. When Home Intercom and Distinctive Ring Service are provided on the same Local Exchange Service line, Home Intercom utilizes the same ringing pattern as one of the dependent numbers serving off the Distinctive Ring Master Number.
6. Home Phone Transfer to Intercom Feature (C)
 - a. The Home Phone Transfer to Intercom feature is offered only on residence lines and each such line must have at least two fully operational telephones. (C)
 - b. The Home Phone Transfer to Intercom feature can be provided with other Custom Calling Service features, however, the Call Waiting feature is disabled for the duration of an intercom call. (C)
 - c. When the Home Phone Transfer to Intercom feature and Priority Call are provided on the same Local Exchange Service line, the Intercom Code Dialing feature and Selective Call Transfer feature utilize the same ringing patterns as Priority Call. (C)

Issued by authority of an Order of the Public Service Commission of West Virginia in Case No. 11-0799-T-T dated June 21, 2011.

Issued: June 2, 2011

Effective: July 2, 2011

CUSTOM CALLING SERVICES

B. REGULATIONS (Cont'd)

6. Home Phone Transfer to Intercom Feature (Cont'd)

- d. When the Home Phone Transfer to Intercom feature and Distinctive Ring Distinctive Ringing Service are provided on the same Local Exchange Service line, the Intercom Code Dialing feature and Selective Call Transfer feature utilize the same ringing patterns as the dependent numbers serving off the Distinctive Ring Master Number.
- e. The Home Phone Transfer to Intercom feature can only be utilized through the use of compatible customer-provided terminal equipment.
- f. Customers who subscribe to the Home Phone Transfer to Intercom feature receive Three-way Calling as a part of the service. Therefore, customers ordering the Home Phone Transfer to Intercom feature who currently have Three-way Calling as an individual feature, or as part of a Residence Feature Package, will have the feature deleted from their account as an individual feature or as a part of the Residence Feature Package.

7. Customers with the following features may request these features on a pay-per-use basis or on a monthly subscription basis:

- Busy Number Redial (C)
- Call Return (*69) (C)
- Three-way Calling (C)

When requested on a pay-per-use basis, the activation charge is applied when the feature is initiated, whether the call is completed or not.

For *69, per activation customers are charged upon announcement of the telephone number associated with the last incoming call. The charge applies regardless of whether the customer attempts to return the call by dialing "1" and regardless of whether the announced number identifies the calling party or can be used to return the call automatically or by manual dial back. Additional charges associated with calls returned using *69 will apply.

8. Busy Redial and *69 usage capability is available to Residence Individual Dial Tone Lines and Business Individual Dial Tone Lines.

CUSTOM CALLING SERVICES

B. REGULATIONS (Cont'd)

9. Fixed Call Forwarding

- a. Fixed Call Forwarding are those arrangements whereby incoming calls are transferred to another telephone number. These arrangements are established with the Telephone Company on a fixed basis and may only be rearranged by notifying the Telephone Company of the new telephone number to which the calls are to be transferred.
- b. Fixed Call Forwarding may be associated with individual lines, and Private Branch Exchange (PBX) trunks. Fixed Call Forwarding arrangements are only available to customers served by compatible electronic type switching equipment.

(M)

(M)

(x) Material now appearing on this page previously appeared on 1st Revised Page 10.

Issued by authority of an Order of the Public Service Commission of West Virginia in
Case No _____ Dated _____.

Issued: September 20, 2007

Effective: October 5, 2007

Frontier West Virginia Inc.

Section 21
2nd Revised Page 11
Cancels 1st Revised Page 11

CUSTOM CALLING SERVICES

B. REGULATIONS (Cont'd)

9. Fixed Call Forwarding (Cont'd)

c. Calls forwarded by these arrangements are subject to local and long distance message charges. These arrangements contemplate that normal transmission performance quality cannot be guaranteed to all calls forwarded.

d. Call Forwarding - Don't Answer

Call Forwarding - Don't Answer is a fixed arrangement which automatically routes incoming calls to the designated telephone number when the called line doesn't answer before passage of a predetermined interval.

At the time a line is initially equipped for Call Forwarding - Don't Answer, it will be arranged for a predetermined number of ringing cycles to be completed prior to the incoming call being forwarded. The customer may change their number of rings, within limits specified by the Telephone Company, through a remote access directory number.

e. Call Forwarding - Busy Line

Call Forwarding - Busy Line is a fixed arrangement which automatically routes incoming calls to the designated telephone number when the called line is busy.

10.

(D)

(D)

Effective May 31, 2010, the Ultra Forward feature, formerly contained in this section, is hereby cancelled and withdrawn.

(C)

(C)

Issued by authority of an Order of the Public Service Commission of West Virginia
in Case No. _____ dated _____ .

Issued: April 16, 2010

Effective: May 31, 2010

Frontier West Virginia Inc.

Section 21
5th Revised Page 11a
Cancels 4th Revised Page 11a

CUSTOM CALLING SERVICES

B. REGULATIONS (Cont'd)

10.

11. Features Plan - Business

(C)

Features Plan - Business is available only to customers whose basic service is provided over the Telephone Company's access lines.

(C)

<u>Package</u>	<u>Package Features</u>	<u>Notes</u>
1	Call Waiting Three-Way Calling	NOT available to multi-line hunt group customers
2	Call Waiting Three-Way Calling Caller ID	NOT available to multi-line hunt group customers
3	Call Waiting Caller ID	NOT available to multi-line hunt group customers
4	Call Waiting Three-Way Calling Caller ID	NOT available to multi-line hunt group customers
5	Call Waiting Call Forwarding Caller ID	NOT available to multi-line hunt group customers
6	Call Forwarding Three-Way Calling Caller ID	Available to multi-line hunt group customers
7	Three-Way Calling Caller ID	Available to multi-line hunt group customers

(O)

(O)

Issued by authority of an Order of the Public Service Commission of West Virginia in Case No. 11-0799-T-T dated June 21, 2011.

Issued: June 2, 2011

Effective: July 2, 2011

Frontier West Virginia Inc.

Section 21
2nd Revised Page 11b
Cancels 1st Revised Page 11b

CUSTOM CALLING SERVICES

B. REGULATIONS (Cont'd)

11. Features Plan - Business (Cont'd) (C)
- a. Individual measured or unlimited POTS class of service is required.
 - b. Touch tone service is required.
 - c. The Features Plan - Business is restricted to customers with 20 (twenty) lines or less. (C)
 - d. The Features Plan - Business features will be provided in equipped areas, that is, where the features are available. (C)
 - e. The Features Plan - Business is not available to ISDN, Analog and Digital Centrex customers, PBX trunks and Coin or COCOT customers. (C)
 - f. The customer is required to purchase all associated CPE/hardware.
 - g. Packages with Call Waiting cannot be used on a multi-line hunt group.
 - h. If the customer enters into a term agreement, the Features Plan - Business rates provide a discount of 10% on the total of the individual feature rates for a one-year term, 15% for a two-year term, and 20% for a three-year term. When an additional business access line is ordered and equipped with the Features Plan - Business an additional discount of 10% is given to the Features Plan - Business associated with that line. (C)
 - i. The Features Plan - Business feature packages may be relocated to a different premises served by the same central office or to another central office without incurring termination charges. If the new location does not have the Features Plan - Business available and the move is prior to the expiration date, no termination fee will apply. (C)
 - j. The customer must retain the Features Plan - Business for the duration of the commitment period. If the Features Plan - Business is disconnected prior to the expiration of the commitment period, termination charges will be applied as follows: (C)
 - No termination charge if the Features Plan - Business is disconnected with the first sixty (60) days following placement of the order. (C)
 - No termination charge if the customer upgrades to a Centrex product (Communications System or Centrex Full Feature Business Voice System) before the end of the commitment period. (C)
 - No termination charge if the customer changes the Features Plan - Business or changes the duration of the commitment period. (C)
 - A termination charge in the amount of fifty dollars (\$50.00) applies if the Features Plan - Business is disconnected after sixty (60) days following placement of the order and prior to the expiration of the commitment period. (C)
 - k. A customer may, at any time prior to the expiration of the commitment period, change to a longer or shorter commitment period, or change to a different package at the effective discount tariff rate. Nonrecurring charges do not apply for these changes.

Issued by authority of an Order of the Public Service Commission of West Virginia in Case No. 11-0799-T-T dated June 21, 2011.

GENERAL SERVICES TARIFF
P.S.C.-W.Va.-No. 203

Frontier West Virginia Inc.

Section 21
2nd Revised Page 11c
Cancels 1st Revised Page 11c

CUSTOM CALLING SERVICES

B. REGULATIONS (Cont'd)

- 11. Features Plan - Business (Cont'd) (C)
 - 1. Customers will not be allowed to suspend their service with the Features Plan - Business on any lines. If a customer wants to suspend their service, then they will have to disconnect the Features Plan - Business. (C)
(C)
(C)

Issued by authority of an Order of the Public Service Commission of West Virginia in Case No. 11-0799-T-T dated June 21, 2011.

GENERAL SERVICES TARIFF
P.S.C.-W.Va.-No. 203

Frontier West Virginia Inc.

Section 21
11th Revised Page 12
Cancels 10th Revised Page 12

CUSTOM CALLING SERVICES

B. REGULATIONS (Cont'd)

C RATES

	Usage Charge	<u>Per Month, Per Line Equipped</u>	
		<u>Residence</u>	<u>Business</u>
1. Anonymous Call Rejection To Caller ID - Number Only and Caller ID Customers.....	-	-	-
2. Selective Call Rejection.....	-	\$4.39	*
3. Call Forwarding.....	-	4.38 (I)	*
4. Call Trace.....	\$1.15 (I)	-	-
5. Call Waiting.....	-	5.60 (I)	*
6. Caller ID - Number Only.....	-	7.25	*
7. Caller ID.....	-	8.96 (I)	*
8. Fixed Call Forwarding, per line			
Busy Line.....	-	2.41 (I)	*
Don't Answer.....	-	2.41 (I)	*
Both Busy Line and Don't Answer....	-	2.31 (I)	*
9. Home Intercom.....	-	2.35	-
10. Distinctive Ring per dependent number..	-	4.74	*
11. Home Phone Transfer to Intercom.....	-	6.50	-
	<u>Non- recurring Charge</u>		
12. Number/Name Display Prevention (For non-published customers only)	\$5.00	-	-

* Rates deregulated.

Issued by authority of an Order of the Public Service Commission of West Virginia
Case No. 18-1330-T-T dated October 16, 2018.

Issued: October 5, 2018

Effective: October 21, 2018

GENERAL SERVICES TARIFF
P.S.C.-W.Va.-No. 203

Frontier West Virginia Inc.

Section 21
12th Revised Page 13
Cancels 11th Revised Page 13

CUSTOM CALLING SERVICES

C. RATES (Cont'd)

	<u>Usage</u>	<u>Per Month, Per</u> <u>Line Equipped</u>	
	<u>Charge</u>	<u>Residence</u>	<u>Business</u>
14. Priority Call.....	-	\$3.06	**
15. Busy Number Redial			
Per activation.....	\$.86 (I)	-	-
Subscription basis.....	-	2.27	**
16. Residence Package, consisting of two or more features selected from Call Block, Call Forwarding, Call Waiting, Home Intercom, Distinctive Ring, Home Phone Transfer to Intercom, Priority Call, Busy Redial, Select Call Forwarding, *69, Speed Dialing, and Three-way Calling, per individual feature; the Residence Premium Package of services counts as one eligible feature, but no additional discount applies to the package.			
Two-feature Package	27% less than*		
Three-feature Package	27% less than*		
Four-feature Package	30% less than*		
Five-or more feature Package	35% less than*		
17. Residence Call Manager Package	-	12.49	-
18. Selective Call Forwarding	-	4.08	**
19. Call Return (*69)			
Per activation86 (I)	-	-
Subscription basis	-	4.39	**
20. Speed Dialing (Only)**			
Eight-code capacity	-		
Thirty-code capacity	-		
21. The Big Deal	-	18.99	-

* The total of the monthly rates specified for the individual Residence Custom Calling Service features, per line equipped, preceding.

** Rates deregulated.

Issued by authority of an Order of the Public Service Commission of West Virginia in Case No. 18-1330-T-T dated October 16, 2018.

Issued: October 5, 2018

Effective: October 21, 2018

GENERAL SERVICES TARIFF
P.S.C.-W.Va.-No. 203

Frontier West Virginia Inc.

Section 21
8th Revised Page 13a
Cancels 7th Revised Page 13a

CUSTOM CALLING SERVICES

C. RATES (Cont'd)

	<u>Usage</u> <u>Charge</u>	<u>Per Month, Per</u> <u>Line Equipped</u>		
		<u>Residence</u>	<u>Business</u>	
22. Three-way Calling				
Per activation	\$.77 (I)	-	-	
Subscription basis	-	\$4.78 (I)	*	
23. Selective Call Acceptance		5.27	*	(N)
24. Multiple Simultaneous Call Forward ...		-	*	(N)

* Rates deregulated.

Issued by authority of an Order of the Public Service Commission of West Virginia in Case No. 14-1140-T-T dated July 8, 2014.

GENERAL SERVICES TARIFF
P.S.C.-W.Va.-No. 203

Bell Atlantic - West Virginia, Inc.

Section 21
7th Revised Page 13b
Cancels 6th Revised Page 13b

CUSTOM CALLING SERVICES

C. RATES (Cont'd)

	Contract Terms, Discounts and Rates*			USOC	(C)
	1 Year (-10%)	2 Year (-15%)	3 Year (-20%)		
24. Features Plan-Business					
Package 1 Features					
Call Waiting	-	-	-	PKB42	
Three Way Calling	-	-	-		
Total	*	*	*		
w/Additional Dial Tone					
Line:-discount:	*	*	*		
Package 2 Features					
Call Waiting	-	-	-	PKB49	
Three Way Calling	-	-	-		
Caller ID	-	-	-		
Total	*	*	*		
w/Additional Dial Tone					
Line:- discount:	*	*	*		
Package 3 Features					
Call Waiting	-	-	-	PKB48	
Caller ID	-	-	-		
Total	*	*	*		
w/Additional Dial Tone					
Line:- discount:	*	*	*		
Package 4 Features					
Call Waiting	-	-	-	PKB3X	
Three Way Calling	-	-	-		
Caller ID	-	-	-		
Total	*	*	*		
w/Additional Dial Tone					
Line:- discount:	*	*	*		
Package 5 Features					
Call Waiting	-	-	-	PKB3F	
Call Forwarding	-	-	-		
Caller ID	-	-	-		
Total	*	*	*		
w/Additional Dial Tone					
Line:- discount:	*	*	*		
Package 6 Features					
Call Forwarding	-	-	-	PKB3V	
Three Way Calling	-	-	-		
Caller ID	-	-	-		
Total	*	*	*		
w/Additional Dial Tone					
Line:- discount:	*	*	*		
Package 7 Features					
Three Way Calling	-	-	-	PKB47	
Caller ID	-	-	-		
Total	*	*	*		
w/Additional Dial Tone					
Line:- discount:	*	*	*		

Customers subscribing to packages with Call Waiting (CW) and Caller ID will be offered the option of provisioning their line with Call Waiting ID at no extra charge.

* Rates deregulated.

(O)
(O)

Issued by authority of an Order of the Public Service Commission of West Virginia
in Case No. 11-0799-T-T dated June 21, 2011.

Issued: June 2, 2011

Effective: July 2, 2011

GENERAL SERVICES TARIFF
P.S.C.-W.Va.-No. 203

Frontier West Virginia Inc.

Section 22
2nd Revised Page 1
Cancels 1st Revised Page 1

* Effective February 18, 2005, Speech Recognition Service/Voice Dialing Service has been withdrawn and is no longer available.

Issued by authority of an Order of the Public Service Commission of West Virginia
in Case No. _____ dated _____.

Issued: October 19, 2004

Effective: November 3, 2004

GENERAL SERVICES TARIFF
P.S.C.-W.Va.-No. 203

Frontier West Virginia Inc.

Section 23
Original Page 1

Reserved For Future Use

Issued by authority of an Order of the Public Service Commission of West Virginia
in Case No. _____ dated _____.

Issued: January 8, 2001

Effective: January 8, 2001

Frontier West Virginia Inc.

Section 24
1st Revised Page 1
Cancels Original Page 1

OUTGOING CALL RESTRICT SERVICE

(C)

A. GENERAL

Outgoing Call Restrict Service is an optional outgoing call management service that provides residential and business customers the ability to block or allow calls initiated from their line. (C)

B. REGULATIONS

1. Outgoing Call Restrict Service allows the subscriber to activate or deactivate the feature, and modify the screening parameters through the use of a touch tone telephone. In addition, Outgoing Call Restrict Service allows the subscriber to use a Personal Identification Number (PIN) during an interactive announcement to override any call restriction. (C)

The subscriber will be able to maintain and modify screening lists from a touch tone telephone. The list can be divided into two subsets, dialed numbers to be allowed - the Allowed Numbers List, and dialed numbers to be restricted - the Blocked Numbers List. The Allowed Numbers List will handle up to 20 different entries while the Blocked Numbers List will handle up to 10 different entries. The Allowed Numbers List can be set up to allow certain specified numbers, area codes, or local exchange prefixes. The Blocked Numbers List can be set up to restrict certain specified numbers, area codes, or local exchange prefixes.

2. Calls to Emergency Services code 9-1-1 and Frontier Repair Service can not be restricted. (C)
3. When calls are placed and the network determines that a call is to be rejected, the calling party will receive an Interactive announcement. The calling party can then override this rejection through the use of a PIN which is customer changeable through a touch tone telephone.
4. From a touch tone telephone, and with a PIN code, the subscriber will be able to modify any of the service features described.
5. The standard Calling Options menu includes:
 - Allow ALL calls
 - Block ALL calls (Except 9-1-1) and Frontier Repair Service (C)
 - Block ALL calls except those on the Allowed Numbers List (Except 9-1-1 and Frontier Repair Service)* (C)
 - Block calls on the Blocked Numbers List and allow those calls on the Allowed Numbers List*
 - Block all intraLATA toll, interLATA toll, 900 and 700 calls.**
6. A subscriber may modify Outgoing Call Restrict Service parameters on their line from any touch tone equipped telephone by dialing an access number and following the directions provided. (C)

* Directory Assistance, Operator, and International calls can be blocked when using this option.

** The Allowed Number List, if activated, can still be used for additional screening with this option.

Issued by authority of an Order of the Public Service Commission of West Virginia in Case No. 11-0799-T-T dated June 21, 2011.

GENERAL SERVICES TARIFF
P.S.C.-W.Va.-No. 203

Frontier West Virginia Inc.

Section 24
2nd Revised Page 2
Cancels 1st Revised Page 2

OUTGOING CALL RESTRICT SERVICE (C)

B. REGULATIONS (Cont'd)

- 7. A subscriber may modify Outgoing Call Restrict Service parameters on their line from any touch-tone-equipped telephone by dialing an access number and following the directions provided. (C)
- 8. Outgoing Call Restrict Service is offered only where the customer's location is served by a central office switch equipped with Advanced Intelligent Network (AIN) and Common Channel Signaling/Signaling System 7 (CCS/SS7) architecture and software. (C)
- 9. Outgoing Call Restrict Service is available for use with Residence and Business Dial Tone Lines. (C)
- 10. Outgoing Call Restrict Service does not relieve the customer of responsibility for calls charged to their telephone number(s). (C)
- 11. The Company shall not be liable to the customer or any other person or entity for damages of any nature or kind arising out of, resulting from, or in connection with the provision of the service, including without limitation, the inability to access the operator or any telephone number. (C)

C. RATES

1. Application of Rates

- a. An installation charge is applicable when adding Outgoing Call Restrict Service to an existing access line. (C)
- b. An installation charge does not apply to assumption of service from another customer when there has been no lapse in the provision of such service.

	Installation Charge	Per Month	USOC	
2. Outgoing Call Restrict, per line equipped				(C)
Residential.....	\$5.00	\$5.20	OC4	
Business.....	5.00	4.00	OC4	

Issued by authority of an Order of the Public Service Commission of West Virginia in Case No. 11-0799-T-T dated June 21, 2011.

Issued: June 2, 2011

Effective: July 2, 2011

DO NOT DISTURB SERVICE

A. GENERAL

Do Not Disturb Service is an optional incoming call management service that provides residential customers the ability to block or allow incoming calls to their line.

B. REGULATIONS

1. Do Not Disturb Service allows the customer to activate or deactivate the Service and modify the screening parameters through the use of a touch-tone telephone.
2. Initial activation of the service must take place from the customer's telephone line equipped with the service; however, updates to the service can be made from any touch-tone phone in the U.S.
3. Do Not Disturb customers are given three options for activating the Service. By dialing a Toll Free number from anywhere in the U.S., they can:
 - a. turn on Do Not Disturb until they turn it off (by calling the Toll Free number again);
 - b. turn on Do Not Disturb, to be turned off automatically in 1 to 24 hours;
 - c. pre-program a schedule for turning Do Not Disturb on and off automatically on selected days of the week.
4. Do Not Disturb customers are given a temporary personal identification number (PIN) when they initially subscribe to the service. Upon the first activation, they are required to change the PIN which will be used from then on to activate the service or change the options of the service.
5. Customers can customize their Do Not Disturb Service by choosing one of three announcements that callers will hear when Do Not Disturb is activated. If the customer has a voice mail service (Verizon's Home Voice Mail or another voice mail service), the announcement can be appended with an offer to leave a message in the voice mailbox.
6. Customers are able to allow special callers to reach them in one of two ways when Do Not Disturb is activated: the creation of a Priority Caller List (with 15 numbers) which allows only the numbers of specific callers to ring through; or the creation of a four-digit Override code which allows those callers who know the code to bypass the restriction, if they are calling from a touch-tone phone.
7. When calls are placed to an active Do Not Disturb customer, callers (except those on the Priority Caller List) hear the Do Not Disturb announcement. If a caller has the Override code, they will dial the code either during or after the announcement. All other calls will be blocked.
8. Do Not Disturb Service is offered only where the customer's location is served by a central office switch equipped with Advanced Intelligent Network (AIN) and Common Channel Signaling/ Signaling System 7 (CCS/SS7) architecture and software.

GENERAL SERVICES TARIFF
P.S.C.-W.Va.-No. 203

Frontier West Virginia Inc.

Section 24A
Original Page 2

DO NOT DISTURB SERVICE

B. REGULATIONS (Cont'd)

9. Do Not Disturb Service is available for use with Residence Dial Tone Lines.
10. The Telephone Company shall not be liable to the customer or any other person or entity for damages of any nature or kind arising out of, resulting from, or in connection with the provision of the service, including without limitation, the inability to be accessed by the operator or any telephone number.

C. RATES

1. Application of Rates

There is no installation charge applicable when adding Verizon Do Not Disturb Service to an existing access line.

- | | | |
|--|----------------------------|----------------------|
| 2. Do Not Disturb,
per line equipped..... | <u>Per Month</u>
\$3.00 | <u>USOC</u>
D7TL1 |
|--|----------------------------|----------------------|

PROTECTION EQUIPMENT FOR SERVICES TO POWER STATIONS

A. GENERAL

Protection Equipment For Services to Power Stations is equipment furnished customers to protect Telephone Company services extending to electric power generating, switching and distributing locations from the effects of ground potential rise and/or induction caused by faults in the electric power system. The protection equipment is designed to isolate the fault produced hazardous voltages.

B. REGULATIONS

1. Requirements for High Voltage Protection Equipment

High voltage protection equipment is required on telephone facilities at the customer location in accordance with the current Institute of Electrical and Electronic Engineers' guide, Standard 487 entitled "IEEE Guide for the Protection of Wire-Line Communication Facilities Serving Electric Power Stations". At a minimum, such equipment will be required under the following conditions.

- a. When the fault produced ground potential rise and/or induction at the customer location is 1000 volts peak or greater.
- b. When the fault produced ground potential rise and/or induction at the customer location is 300 volts peak or greater and at least one telecommunication service has been assigned as a Class A Service Performance Objective, as defined in 2.b. following, by the customer.

2. Responsibility of the Customer

As a condition of service, the customer shall be responsible for providing, in writing, to the Telephone Company the following information.

- a. The technical data needed by the Telephone Company to determine the ratings and requirements of the protection equipment at each location where service is requested. This data includes, but is not limited to, the ground potential rise, in root-mean-square volts, under worst case single phase to ground fault conditions, the single phase to ground fault return current which produces the ground potential rise, the ground grid area, impedance of the station ground grid to remote earth, and reactance to resistance ratio at the worst case point of fault. Where necessary, the customer will provide upon request by the Telephone Company fault current diagrams and maps of relevant power feed routes.

Issued by authority of an Order of the Public Service Commission of West Virginia in Case No. _____ dated _____.

PROTECTION EQUIPMENT FOR SERVICES TO POWER STATIONS

B. REGULATIONS (Cont'd)

2. Responsibility of the Customer (Cont'd)

- b. The service type and Service Performance Objective classification as specified in the current Institute of Electrical and Electronic Engineers' guide, Standard 487 entitled "IEEE Guide for the Protection of Wire-Line Communication Facilities Serving Electric Power Stations".
- c. The quantity and projected forecast of each service requested at a given location, including those requested by contractors or any other temporary service needs.
- d. Changes in the information previously provided that may affect the protection arrangement shall require written notification. Notification of these changes shall be provided with sufficient advanced notice to permit reevaluation, redesign, implementation and tests of the modified or new protection method. In addition, the customer shall annually provide the Telephone Company with a validation of the information previously provided.

3. Determination of Protection Required

The Telephone Company, working in conjunction with the customer and with data provided by the customer, shall determine the proper levels of protection and, in the event the Telephone Company provides the necessary high voltage protection equipment, the Telephone Company shall determine the proper methods of protection. The methods of protection shall, in any event, be approved by the Telephone Company. In the event of service additions, deletions, rearrangements, maintenance or other circumstances, the levels and/or methods of protection must continue to meet the approval of the Telephone Company. The levels and/or methods of protection for every service in a cable shall be coordinated by the Telephone Company or with the approval of the Telephone Company, to be compatible with the protection provided for the most critically important service in that cable.

4. Provision of High Voltage Protection Equipment

- a. The Telephone Company will provide the necessary high voltage protection equipment at rates specified in C. following. The Telephone Company will inspect and verify the protection equipment when service is established at new or existing customer locations, and at future times as deemed necessary due to service additions, deletions, rearrangements, maintenance or other circumstances.

Issued by authority of an Order of the Public Service Commission of West Virginia in Case No. _____ dated _____.

PROTECTION EQUIPMENT FOR SERVICES TO POWER STATIONS

B. REGULATIONS (Cont'd)

4. Provision of High Voltage Protection Equipment (Cont'd)

- b. As an option, the customer may furnish the necessary high voltage protection equipment on their premises or furnish fiber optic cable to a point of connection outside the area of ground potential influence. If the customer provides the equipment, it must meet the Telephone Company's technical criteria and be approved by the Telephone Company in writing prior to its installation. The Telephone Company will provide engineering consultation with the customer to determine the requirements of the protection equipment and the design of the protection installation. The Telephone Company will inspect and verify the protection installation when service is established at a new or existing customer location and when the configuration of the protection arrangement at the power station changes at the appropriate charge as set forth in C.6. following. In addition, the customer will provide access for the Telephone Company to inspect and verify the protection installation at regular intervals thereafter as determined by the Telephone Company and at other times as deemed necessary by the Telephone Company due to service additions, deletions, rearrangements, maintenance or other circumstances. The installation must continue to meet the approval of the Telephone Company.
- c. Equipment cabinets, nonmetallic conduits and other mounting arrangements on the customer's premises or in connection with the furnishing of fiber optic cable may be provided by the customer, or by the Telephone Company on a Special Equipment and Service Arrangement or Construction Charges basis, as appropriate.
- d. At a given location, all high voltage protection equipment must be provided by either the Telephone Company or the customer.

C. RATES

1. Equipment for up to 18,000 Root-mean-square Volts Protection

a. Card Mounting Shelf	<u>Installation Charge</u>	<u>Per Month</u>	<u>USOC</u>
Two-card Type	\$500.00	\$34.00	HVQ12
Eight-card Type	500.00	51.00	HVQ18

Issued by authority of an Order of the Public Service Commission of West Virginia in Case No. _____ dated _____.

GENERAL SERVICES TARIFF
P.S.C.-W.Va.-No. 203

Frontier West Virginia Inc.

Section 25
Original Page 4

PROTECTION EQUIPMENT FOR SERVICES TO POWER STATIONS

C. RATES (Cont'd)

1. Equipment for up to 18,000 Root-mean-square
Volts Protection (Cont'd)

	<u>Per Month</u>	<u>USOC</u>
b. Power Supply, each		
24-Volts Direct Current Supply, with battery backup, requires 115 volts alternating current local power ...	\$11.50	HV21A
24-Volts Direct Current Supply, operates from 130 volts direct current station battery	11.00	HV21B
48-Volts Direct Current Supply, requires 115 volts alternating current local power	10.00	HV21C
c. Plug In Isolator Cards, each		
Universal Telephone Card, suitable for loop start voice telephone service	21.50	HV61U
Alternating Current Card, suitable for exchange or Channel Services requiring alternating current trans- mission only	11.50	HV61A
Private Branch Exchange (PBX) Trunk Card, suitable for voice telephone service, automatic or manual PBX, loop or ground start and battery polarity reversals ..	25.50	HV61P
Direct Current Trip/Pilot Wire Card, suitable for use with direct current trip system or pilot wire system .	27.00	HV61D
Coin Card, suitable for Pay Telephone Network Lines ..	54.00	HV61C
Off-premises Extension Card, suitable for off-premises extension of PBX station lines	30.00	HV61E
T Carrier Card, suitable for Service At a Transmission Speed of 1.544 Megabits Per Second	24.00	HV61M
d. 15,000 Volts Lightning Arrestor.....	9.50	HAV

Issued by authority of an Order of the Public Service Commission of West Virginia
in Case No. _____ dated _____.

Issued: January 8, 2001

Effective: January 8, 2001

GENERAL SERVICES TARIFF
P.S.C.-W.Va.-No. 203

Frontier West Virginia Inc.

Section 25
Original Page 5

PROTECTION EQUIPMENT FOR SERVICES TO POWER STATIONS

C. RATES (Cont'd)

2. Neutralizing Transformers (LA-2), Suitable for Exchange and Channel Services Requiring Direct Current Transmission

a. Single Channel Units	<u>Installation Charge</u>	<u>Per Month</u>	<u>USOC</u>
(1) Up to 4000 volts, steady state voltage, interior or exterior mounted units, each	\$117.38	\$14.37	PJX
(2) Up to 8000 volts, steady state voltage, exterior mounted units only, each	234.76	47.51	PL7
(3) Neutralizing transformers which provide protection over 8000 volts, steady state voltage, will be provided in single channel units as specified for Special Equipment and Service Arrangements in this Company's General Regulations Tariff, Section 1.			

b. Multiple Channel Units

Neutralizing transformers will be provided in multichannel units as specified for Special Equipment and Service Arrangements in this Company's General Regulations Tariff, Section 1.

3. Isolating Transformers Suitable for Channel Services Requiring Alternating Current Transmission

Single Channel Units, up to 9000 volts, steady state voltage interior mounted units only, each.....	<u>Installation Charge</u>	<u>Per Month</u>	<u>USOC</u>
	\$59.25	\$8.50	PKX

4. Mutual Drainage Reactors, suitable for exchange or Channel Services requiring direct or alternating current transmission, where provided at either the customer location, Telephone Company central office or intermediate location, interior mounted units only, each.....

	30.18	6.48	PU8
--	-------	------	-----

5. Channels furnished for remote grounding are provided at the rates and charges specified for Series 1000, type 1001, Channels, in this Company's Channel Services Tariff, Section 2.

6. Inspection Fee, for initial engineering consultation and inspection of customer-premises equipment installation at existing and new service locations and when the configuration of the protection arrangement of the power station changes....\$120.00

Issued by authority of an Order of the Public Service Commission of West Virginia in Case No. _____ dated _____.

BUSINESS BASIC PLAN CALL ROUTING SERVICE *(LA-3) (C)

A. GENERAL

Business Basic Plan Call Routing Service permits customized call routing to a specific location using: 1) a defined geographical area or 2) the caller's NXX. (C)

B. REGULATIONS

1. Business Basic Plan Call Routing Service is available as a Basic or Deluxe service with several rate options including volume discounts with 3 or 5 year Agreements. Per call billing service is available to Business Basic Plan subscribers who require direct billing of charges to their customers. (C)

Business Basic Plan Call Routing Service - Basic (C)
Business Basic Plan Call Routing Service - Basic provides a unique 936 telephone number for local call routing to a specific location using: 1) a defined geographical area or 2) the caller's NXX. Billing of charges for informational program services is also available with Business Basic Plan Basic service. (C)

Business Basic Plan Call Routing Service - Deluxe (C)
Business Basic Plan Call Routing Service - Deluxe provides a premium 555 telephone number for local call routing to a specific location using: 1) a defined geographical area or 2) the caller's NXX. Billing of charges for informational program services is also available with Business Basic Plan Deluxe service. (C)

2. Business Basic Plan Call Routing Service is subject to the availability of the Advanced Intelligent Network capability, network facilities and Billing capabilities. No mass calling type services will be permitted until such time as Network Management capability is available. In no event shall Frontier West Virginia Inc. be liable for any losses or damages of any kind resulting from the unavailability or failure of its equipment or facilities or for any act, omission or failure of performance by Frontier West Virginia Inc., or employees, or agents. (C)

3. Business Basic Plan Call Routing Service calls from Independent Local Exchange Carriers, Other Telephone Companies, Cellular carriers, etc. will require special arrangements and agreements with Frontier West Virginia Inc. before Business Basic Plan Call Routing Service is available. (C)

4. Business Basic Plan Call Routing Service is furnished upon the condition that the Subscriber obtain adequate terminating facilities to permit the use of Business Basic Plan Call Routing Service without injurious effect upon it or any other services rendered by the Company. Frontier West Virginia Inc. may terminate or refuse to furnish service to any subscriber, without incurring any liability, if use of the service would interfere with or impair other services provided by the Company, provided that, in the case of a termination of service, at least five days have elapsed following written notification to the customer by mail, or in person, of Frontier West Virginia Inc.'s intention to terminate the service for such cause. (C)

5. All calls must originate and terminate at the subscriber's equipment within the LATA. (C)

6. Callers to a Business Basic Plan Call Routing Service telephone number will be charged for a local call. In addition, if a Business Basic Plan call is to a Pay-Per-Call service, the charges as specified by the Business Basic Plan subscriber will appear as a separate billing charge on the caller's Frontier West Virginia Inc.'s bill. (C)

* (LA-3) Effective June 12, 2009, BUSINESS BASIC PLAN CALL ROUTING SERVICE as provided in this tariff, is no longer available to new customers. Existing BUSINESS BASIC PLAN CALL ROUTING SERVICE customers may continue their service until their BUSINESS BASIC PLAN CALL ROUTING SERVICE contract expires or their service is disconnected, whichever occurs first. Moves, additions or changes to subscribers' existing service will not be permitted. (C)

Frontier West Virginia Inc.

Section 26
2nd Revised Page 1a
Cancels 1st Revised Page 1a

BUSINESS BASIC PLAN CALL ROUTING SERVICE *(LA-3) (C)

B. REGULATIONS (Cont'd)

7. Information providers (Ips) must abide by the same limitations, restrictions, disclosures, etc. as are included in the Telephone Disclosure and Dispute Resolution Act (TDDRA) of 1992. Under the statute, Federal Communications Commission's (FCC) regulations impose obligations and constraints on common carriers that transmit or bill for such services. Information providers must also abide by the same regulations included in the Federal Trade Commission (FTC) Telemarketing Act. The FTC's regulations control the activities of information providers that produce pay per call programs and other entities, including common carriers, that perform pay per call billing and collection. Business Basic Plan Pay-Per-Call programs not in compliance with these rules shall be terminated immediately after due process. (C)
8. A clear and distinct Preamble to a Pay-Per-Call service must notify the caller of the charges to be billed for this call. The Preamble must notify and give the caller sufficient time to hang up before Pay-Per-Call charges are charged. Callers will be charged for calls greater than 15 seconds.
9. At the request of any residence, business or coin customer of Frontier West Virginia Inc., Business Basic Plan Basic or Deluxe Pay-Per-Call service may be restricted on an individual line basis without charge. This arrangement would restrict completion of all Business Basic Plan Pay-Per-Call services within the LATA. Non-pay per call services would not be restricted. Rates for subsequent requests for blocking are specified in Section C. following. (C)
10. An exception to line restriction is 555-1212. In the Code of Federal Regulations Title 47, Part 64, Subpart 0 Section 64.1501 (a)(4) directory services provided by a common carrier or its affiliate or by a local exchange carrier or its affiliate, or any service for which users are assessed charges only after entering into a presubscription or comparable arrangement with the provider of such service are not pay per call services. (C)
11. Frontier West Virginia Inc. is only responsible for the maintenance and operation of the Business Basic Plan network facilities, and assumes no liability for the content(s) or accuracy of messages provided by the subscriber. Programs, both live and recorded whose message is sexually explicit, lewd, or otherwise considered to be adult as that term is commonly understood, is not available, acceptable or permissible with Business Basic Plan. Such services will be disconnected. (C)

- * (LA-3) Effective June 12, 2009, BUSINESS BASIC PLAN CALL ROUTING SERVICE as provided in this tariff, is no longer available to new customers. Existing BUSINESS BASIC PLAN CALL ROUTING SERVICE customers may continue their service until their BUSINESS BASIC PLAN CALL ROUTING SERVICE contract expires or their service is disconnected, whichever occurs first. Moves, additions or changes to subscribers' existing service will not be permitted. (C)

Issued by authority of an Order of the Public Service Commission of West Virginia in Case No. 11-0799-T-T dated June 21, 2011.

BUSINESS BASIC PLAN CALL ROUTING SERVICE *(LA-3) (C)

B. REGULATIONS (Cont'd)

12. Number Reservation. All Business Basic Plan Call Routing Service-Basic and Deluxe Numbers are software design only. (C)

a. Business Basic Plan Call Routing Service-Basic (C)

Frontier will assign Business Basic Plan Call Routing Service Basic numbers using a unique NPA-936-XXXX for the service. Specific Numbers will be reserved at no charge for a maximum of three months only. (C)

b. Business Basic Plan Call Routing Service-Deluxe (C)

Subscribers must reserve and be assigned a (NPA-555-XXXX) number by the North American Numbering Plan Administration, the custodian of "555" NXX codes, prior to activation of the service in each NPA. 555 Line Numbers will be assigned on either a national or non-national basis. National assignment means that the 555 Line Number assignee may use that number in any NPA in the North American Numbering Plan (NANP) area. A non-national assignment means the 555 Line Number may be used in a specific geographical area by one entity and the same 555 Line Number may be assigned and used by other entities in other geographical areas. Subscribers must render to Frontier a copy of the "Administrator's Response/Confirmation Form" prior to service activation of the NPA 555-XXXX number. For further details, reference BellCore IL-94/05-004 and ICCF 94-0429-002. (C)

c. In cases of future geographic NPA relief activity accomplished by either NPA splits, overlays, boundary realignments, etc., the number assignees of a Business Basic Plan Call Routing Service-Basic or Business Basic Plan Call Routing Service-Deluxe number must reserve and request activation of the same number in the new NPA. A one-time service establishment charge will apply for service activation of the new NPA. (C)

13. Call Routing Database.

a. The service logic in the call routing database will determine the route of the call using the calling party's NPA or NPA-NXX. The Business Basic Plan Call Routing Service subscriber is required to supply an information table where calls are to be routed for each subscriber terminating call location. Most Business Basic Plan Call Routing Service applications are not expected to exceed the maximum allowable database size. If large, complex, and/or sophisticated routing applications exceed the maximum allowable database size, these applications will be handled on a Custom Routing basis. All Percentage Routing and Time-of-Day applications are considered Custom Routing. (C)

b. Custom Routing applications are designed and priced based on Special Equipment and Service Arrangements as specified in the General Regulations Tariff. (C)

* (LA-3) Effective June 12, 2009, BUSINESS BASIC PLAN CALL ROUTING SERVICE as provided in this tariff, is no longer available to new customers. Existing BUSINESS BASIC PLAN CALL ROUTING SERVICE customers may continue their service until their BUSINESS BASIC PLAN CALL ROUTING SERVICE contract expires or their service is disconnected, whichever occurs first. Moves, additions or changes to subscribers' existing service will not be permitted. (C)

Issued by authority of an Order of the Public Service Commission of West Virginia in Case No. 11-0799-T-T dated June 21, 2011.

GENERAL SERVICES TARIFF
P.S.C.-W.Va.-No. 203

Frontier West Virginia Inc.

Section 26
2nd Revised Page 2a
Cancels 1st Revised Page 2a

BUSINESS BASIC PLAN CALL ROUTING SERVICE *(LA-3) (C)

B. REGULATIONS (Cont'd)

14. Pay-Per Call calls to Business Basic Plan telephone numbers will not be completed from the following types of services: (C)

- Operator Handled Calls (O+ and O-)
- Hotel/Motel/Hospital Services
- Inmate Service
- Cellular Service
- Coin/Coinless and Customer Owned Coin Operated Telephones
- Independent or Other Telephone Companies unless access charges and billing arrangements have been established
- Services with Selective Class of Call Screening

15. Frontier West Virginia Inc. will track all adjustments for calls made to each Business Basic Plan Pay-Per-Call service number. A summary of adjustments including uncollectibles will appear on the Payment Statement to the Subscriber. Frontier West Virginia Inc. will make adjustments for Pay-Per-Call charges as follows: (C)

When a customer makes a first time claim for credit on the basis that:
(1) the customer did not approve or have awareness that the call(s) was made, or (2) the customer did not have knowledge of the price per call due.

By accepting an Adjustment, the customer waives any future claims for an automatic adjustment on Pay-Per-Call(s).

Frontier West Virginia Inc. will initiate line restriction for those customers who receive a one time adjustment of \$20.00 or more. (C)

A twenty-five percent (25%) Revenue Adjustment Surcharge will be assessed the Business Basic Plan Subscriber on the dollar value of Pay-Per-Call calls adjusted and uncollected. (C)

16. The subscriber's Pay-Per-Call charges cannot be greater than \$5.00 per call.

17. A monthly remittance check will be sent to the Business Basic Plan Pay-Per-Call subscriber. The amount will include directly billed charges to the caller plus applicable local and state taxes less the amount of charges written off as an adjustment or uncollectible less Business Basic Plan local and toll transport, Query and billing charges less any Revenue Adjustment Surcharges and any other Frontier charges due. (C)

* (LA-3) Effective June 12, 2009, BUSINESS BASIC PLAN CALL ROUTING SERVICE as provided in this tariff, is no longer available to new customers. Existing BUSINESS BASIC PLAN CALL ROUTING SERVICE customers may continue their service until their BUSINESS BASIC PLAN CALL ROUTING SERVICE contract expires or their service is disconnected, whichever occurs first. Moves, additions or changes to subscribers' existing service will not be permitted. (C)

Issued by authority of an Order of the Public Service Commission of West Virginia in Case No. 11-0799-T-T dated June 21, 2011.

GENERAL SERVICES TARIFF
P.S.C.-W.Va.-No. 203

Frontier West Virginia Inc.

Section 26
2nd Revised Page 3
Cancels 1st Revised Page 3

BUSINESS BASIC PLAN CALL ROUTING SERVICE *(LA-3) (C)

B. REGULATIONS (Cont'd)

18. Calls to disconnected Business Basic Plan Call Routing Service telephone numbers will be routed to a Vacant Code Announcement recording. (C)
19. Business Basic Plan Call Routing Service does not provide for any Frontier Directory listings. (C)

C. RATES

1. Application of Rates

- a. The subscriber is responsible for all local and intraLATA toll call transport rate charges from the calling party's central office to the terminating central office, as outlined below.
- b. All rates for Business Basic Plan Call Routing Service are applied on a jurisdictional IntraLATA basis. (C)
- c. Rates and regulations as specified in other Frontier West Virginia Inc. tariffs would apply, as appropriate, for sufficient lines/trunks to the subscriber's terminating equipment. (C)
- d. An intra-office local call will be charged the calling party in accordance with the class of service of the caller dialing an Business Basic Plan Call Routing Service-Basic or Deluxe call. (C)
- e. One-time Service Establishment charges for Business Basic Plan Call Routing Service -Basic & Deluxe include activation of the advertised number and one "default" forward-to telephone number. Supplemental "forward-to" telephone numbers will be assessed a one-time charge per number. (C)
- f. A Subscriber of Business Basic Plan Call Routing Service-Basic or Business Basic Plan Call Routing Service-Deluxe service may choose from three local transport rating options: (C)
- (1) 60 Month Agreement
 - (2) 36 Month Agreement
 - (3) Month-to-Month (Initial 3 month minimum)

Each transport rating option has a Minimum dollar amount requirement. The subscriber will be billed monthly for actual usage times the Agreement rate. Frontier will perform a 12 month annual "true-up" subsequent to the annual anniversary date of the 60 month or 36 month Agreement option. Frontier will bill the Business Basic Plan Call Routing Service subscriber any difference between the Minimum Annual Charges indicated in C.2.d. below, if greater than the Total 12 Months actual billings. With Month-to-Month service the subscriber will be billed the greater of either Actual Monthly charges or the Monthly Minimum charge indicated in C.2.d. below. (C)

- * (LA-3) Effective June 12, 2009, BUSINESS BASIC PLAN CALL ROUTING SERVICE as provided in this tariff, is no longer available to new customers. Existing BUSINESS BASIC PLAN CALL ROUTING SERVICE customers may continue their service until their BUSINESS BASIC PLAN CALL ROUTING SERVICE contract expires or their service is disconnected, whichever occurs first. Moves, additions or changes to subscribers' existing service will not be permitted. (C)

Issued by authority of an Order of the Public Service Commission of West Virginia in Case No. 11-0799-T-T dated June 21, 2011.

Issued: June 2, 2011

Effective: July 2, 2011

Frontier West Virginia Inc.

Section 26
2nd Revised Page 4
Cancels 1st Revised Page 4

BUSINESS BASIC PLAN CALL ROUTING SERVICE *(LA-3) (C)

C. RATES (Cont'd)

1. Application of Rates (Cont'd)

- g. If Business Basic Plan Call Routing Service is disconnected prior to the expiration of an Agreement, a single payment for early termination of \$1,000, plus one-twelfth of the Minimum Annual Charges times the number of remaining months of the Agreement, plus any "true-up" for months with actual usage is due with the Final Bill. (C)
- h. Business Two-Point Service rates in the Long Distance Service Tariff, Section 2A or Interstate IntraLATA Business Class of Service Dial Station Rates found in the Frontier Telephone Companies FCC tariff No. 4, Section 3.1 apply, as appropriate. (C)

A subscriber will be billed the applicable tariff rate times the actual minutes. These calls are not applied to the Local Transport Agreement minimums.
- i. Local Transport service rates will be billed the subscriber per Business Basic Plan number in each LATA monthly and at the Agreement rate. (C)
- j. A Business Basic Plan Call Routing Service Query charge is assessed the subscriber based on each query of the Basic or Deluxe Data Base, including Ring No Answer and Busy Lines. (C)
- k. Local transport and IntraLATA toll call charges apply only on completed calls which exclude Ring No Answer and Busy lines.
- l. Charges for Custom Reports to meet informational or analytical needs of the subscriber are available on a Special Equipment and Service Arrangements basis as specified in the General Regulations Tariff. Such information might include summaries or distribution of calls by time-of-day, day-of-week, lengths of calls, etc.

2. Rates and Charges

RATE

a. Service Establishment Charges

One-time service establishment charge-Basic per number per LATA	\$1,600.00
One-time service establishment charge-Deluxe per number per LATA	\$2,500.00
One time service establishment charge-Pay Per Call per number per LATA	\$100.00
One-time service establishment charge-Custom Routing Applications	ICB
Each supplemental "forward to" telephone number- per LATA	\$225.00

* (LA-3) Effective June 12, 2009, BUSINESS BASIC PLAN CALL ROUTING SERVICE as provided in this tariff, is no longer available to new customers. Existing BUSINESS BASIC PLAN CALL ROUTING SERVICE customers may continue their service until their BUSINESS BASIC PLAN CALL ROUTING SERVICE contract expires or their service is disconnected, whichever occurs first. Moves, additions or changes to subscribers' existing service will not be permitted. (C)

Issued by authority of an Order of the Public Service Commission of West Virginia in Case No. 11-0799-T-T dated June 21, 2011.

GENERAL SERVICES TARIFF
P.S.C.-W.Va.-No. 203

Frontier West Virginia Inc.

Section 26
2nd Revised Page 5
Cancels 1st Revised Page 5

BUSINESS BASIC PLAN CALL ROUTING SERVICE *(LA-3) (C)

C. RATES (Cont'd)

2. Rates and Charges (Cont'd)

RATE

b. Rearrangements and Changes

Premium Routing Query Data Base Changes
per geographical area or
"forward to" number change \$225.00

Change in Subscriber Pay-Per-Call price..... \$225.00

c. Routing Feature Query Charge
per query \$.01

d. Local Calling Transport

(1) Basic Local Calling
per call per number per LATA

	RATE	
		Minimum Monthly Charge
Month-To-Month		
750 to 2,999.....	\$.11	\$ 82.50
3,000 to 29,999.....	\$.10	\$ 300.00
30,000 to 74,999.....	\$.09	\$2,700.00
75,000+.....	\$.08	\$6,000.00
		Minimum Annual Charge
36 Month Agreement		
750 to 2,999.....	\$.09	\$ 810.00
3,000 to 29,999.....	\$.08	\$ 2,880.00
30,000 to 74,999.....	\$.07	\$25,200.00
75,000+.....	\$.06	\$54,000.00
60 Month Agreement		
750 to 2,999.....	\$.07	\$ 630.00
3,000 to 29,999.....	\$.06	\$ 2,160.00
30,000 to 74,999.....	\$.05	\$18,000.00
75,000+.....	\$.04	\$36,000.00

In addition to the above rates each call
over 10 minutes will be billed an
additional charge \$4.00

* (LA-3) Effective June 12, 2009, BUSINESS BASIC PLAN CALL ROUTING SERVICE as provided in this tariff, is no longer available to new customers. Existing BUSINESS BASIC PLAN CALL ROUTING SERVICE customers may continue their service until their BUSINESS BASIC PLAN CALL ROUTING SERVICE contract expires or their service is disconnected, whichever occurs first. Moves, additions or changes to subscribers' existing service will not be permitted. (C)
(C)
(C)

Issued by authority of an Order of the Public Service Commission of West Virginia in Case No. 11-0799-T-T dated June 21, 2011.

Issued: June 2, 2011

Effective: July 2, 2011

GENERAL SERVICES TARIFF
P.S.C.-W.Va.-No. 203

Frontier West Virginia Inc.

Section 26
2nd Revised Page 6
Cancels 1st Revised Page 6

BUSINESS BASIC PLAN CALL ROUTING SERVICE *(LA-3) (C)

C. RATES (Cont'd)

2. Rates and Charges (Cont'd)

d. Local Calling Transport (Cont'd)

(2) Deluxe Local Calling
per minute/call or fraction thereof
per number per LATA

Month-To-Month	Rate	Minimum Monthly Charge															
1,000 to 5,999.....	\$.0555	\$ 55.50															
6,000 to 59,999.....	\$.0505	\$ 303.00															
60,000 to 149,999.....	\$.0455	\$2,730.00															
150,000+.....	\$.0405	\$6,075.00															
<table style="width: 100%; border-collapse: collapse;"> <thead> <tr> <th style="text-align: left;">36 Month Agreement</th> <th style="text-align: right;">Rate</th> <th style="text-align: right;">Minimum Annual Charge</th> </tr> </thead> <tbody> <tr> <td>1,000 to 5,999.....</td> <td style="text-align: right;">\$.0455</td> <td style="text-align: right;">\$ 546.00</td> </tr> <tr> <td>6,000 to 59,999.....</td> <td style="text-align: right;">\$.0405</td> <td style="text-align: right;">\$ 2,916.00</td> </tr> <tr> <td>60,000 to 149,999.....</td> <td style="text-align: right;">\$.0355</td> <td style="text-align: right;">\$25,560.00</td> </tr> <tr> <td>150,000+.....</td> <td style="text-align: right;">\$.0305</td> <td style="text-align: right;">\$54,900.00</td> </tr> </tbody> </table>			36 Month Agreement	Rate	Minimum Annual Charge	1,000 to 5,999.....	\$.0455	\$ 546.00	6,000 to 59,999.....	\$.0405	\$ 2,916.00	60,000 to 149,999.....	\$.0355	\$25,560.00	150,000+.....	\$.0305	\$54,900.00
36 Month Agreement	Rate	Minimum Annual Charge															
1,000 to 5,999.....	\$.0455	\$ 546.00															
6,000 to 59,999.....	\$.0405	\$ 2,916.00															
60,000 to 149,999.....	\$.0355	\$25,560.00															
150,000+.....	\$.0305	\$54,900.00															
<table style="width: 100%; border-collapse: collapse;"> <thead> <tr> <th style="text-align: left;">60 Month Agreement</th> <th style="text-align: right;">Rate</th> <th style="text-align: right;">Minimum Annual Charge</th> </tr> </thead> <tbody> <tr> <td>1,000 to 5,999.....</td> <td style="text-align: right;">\$.0405</td> <td style="text-align: right;">\$ 486.00</td> </tr> <tr> <td>6,000 to 59,999.....</td> <td style="text-align: right;">\$.0355</td> <td style="text-align: right;">\$ 2,556.00</td> </tr> <tr> <td>60,000 to 149,999.....</td> <td style="text-align: right;">\$.0305</td> <td style="text-align: right;">\$21,960.00</td> </tr> <tr> <td>150,000+.....</td> <td style="text-align: right;">\$.0255</td> <td style="text-align: right;">\$45,900.00</td> </tr> </tbody> </table>			60 Month Agreement	Rate	Minimum Annual Charge	1,000 to 5,999.....	\$.0405	\$ 486.00	6,000 to 59,999.....	\$.0355	\$ 2,556.00	60,000 to 149,999.....	\$.0305	\$21,960.00	150,000+.....	\$.0255	\$45,900.00
60 Month Agreement	Rate	Minimum Annual Charge															
1,000 to 5,999.....	\$.0405	\$ 486.00															
6,000 to 59,999.....	\$.0355	\$ 2,556.00															
60,000 to 149,999.....	\$.0305	\$21,960.00															
150,000+.....	\$.0255	\$45,900.00															

e. Custom Reports

One time development charge
per Report ICB
Monthly Report
per Report per month ICB

f. Enhanced Billing Report

One time service establishment charge
per Report per NPA ICB
Enhanced Billing Report
per Report per month per NPA ICB

g. Pay-Per-Call billing

	Per Month
Package 1 Features	\$75.00
Per number per LATA	
Per call billed	
per number per LATA per month	Rate
1 to 5,999.....	\$.05
6,000 to 59,999.....	\$.04
60,000 to 149,999.....	\$.03
150,000+.....	\$.02

* (LA-3) Effective June 12, 2009, BUSINESS BASIC PLAN CALL ROUTING SERVICE as provided in this tariff, is no longer available to new customers. Existing BUSINESS BASIC PLAN CALL ROUTING SERVICE customers may continue their service until their BUSINESS BASIC PLAN CALL ROUTING SERVICE contract expires or their service is disconnected, whichever occurs first. Moves, additions or changes to subscribers' existing service will not be permitted. (C)

Issued by authority of an Order of the Public Service Commission of West Virginia in Case No. 11-0799-T-T dated June 21, 2011.

Issued: June 2, 2011

Effective: July 2, 2011

GENERAL SERVICES TARIFF
P.S.C.-W.Va.-No. 203

Frontier West Virginia Inc.

Section 26
2nd Revised Page 7
Cancels 1st Revised Page 7

BUSINESS BASIC PLAN CALL ROUTING SERVICE *(LA-3) (C)

C. RATES (Cont'd)

2. Rates and Charges (Cont'd)

h. Pay Per-Call Restriction and Unblocking

	<u>Nonrecurring Charge</u>
Residence (per line)	
Initial restriction	
Subsequent requests, same number	\$ 10.00
Business (per central office or terminating location)	
Initial restriction	
Subsequent requests,	\$100.00
Per line equipped	\$ 3.00
Centrex/Centrex Communication System services	
Initial restriction	
Subsequent requests,	\$100.00
Per line equipped	\$ 3.00

* (LA-3) Effective June 12, 2009, BUSINESS BASIC PLAN CALL ROUTING SERVICE as (C)
provided in this tariff, is no longer available to new customers. Existing (C)
BUSINESS BASIC PLAN CALL ROUTING SERVICE customers may continue their service (C)
until their BUSINESS BASIC PLAN CALL ROUTING SERVICE contract expires or their (C)
service is disconnected, whichever occurs first. Moves, additions or changes to
subscribers' existing service will not be permitted.

Issued by authority of an Order of the Public Service Commission of West Virginia in
Case No. 11-0799-T-T dated June 21, 2011.

Issued: June 2, 2011

Effective: July 2, 2011

Frontier West Virginia Inc.

Section 27
1st Revised Page 1
Cancels Original Page 1

Virtual Private Network Service

A. GENERAL

Private Network Virtual Solutions (PNVS) is a business calling service that allows usage generated by or authorized to subscribed business lines to receive customized treatment. Calls can originate from telephone numbers included in a customer's private dialing plan database (on-net) or from off-net locations (telephone numbers not designated as on-net by the customer) provided pre-defined remote access control parameters are fulfilled. With this service, business customers are able to pre-select call routing instructions and screen call patterns. (C)

B. REGULATIONS

Multi-site businesses will be able to combine their use of the public switched network along with their dedicated private line services to create a virtual private networking service.

PNVS customers must subscribe to either a Location Code Dialing Plan or a Portable Extension Dialing Plan. All other PNVS features are optional services that may be selected by the customer. (C) (C)

1. Explanation of Terms

Private Dialing Plan

Location Code Dialing - option has extension numbers which can indicate a specific customer location. The extension numbers are a combination of digit(s) or access code and digits corresponding to part or all of the customer's North American Numbering Plan telephone number. This dialing plan allows duplication of extension numbers among locations served by different central offices.

Portable Extension Dialing - option allows an extension number that is independent of the North American Numbering Plan. When a user moves from one location to another, his/her public telephone number will change but their assigned extension number can stay the same. This allows any caller within the customer's network to reach the user by dialing the same extension regardless of the user's location.

Off-net/On-net Calling

On-net to On-net - Calls originating from and terminating to a telephone number included in a customer's private dialing plan database. The caller dials a pre-defined dialing plan number for the location to be reached.

Issued by authority of an Order of the Public Service Commission of West Virginia in Case No. 11-0799-T-T dated June 21, 2011.

Virtual Private Network Service

B. REGULATIONS (Cont'd)

1. Explanation of Terms (Cont'd)

Off-net/On-net Calling (Cont'd)

On-net to Off-net - Calls originating from a customer designated on-net location (telephone numbers included in customer's private dialing plan database) and terminating off-net (telephone numbers not included in customer's private dialing plan database). With this type of call, a caller dials a standard 10-digit NANP number in the same manner as placing a long-distance call.

Off-net to on-net - Calls originating from a telephone number not in the customer's private dialing plan database but terminating to a telephone number included in the customer's private dialing plan database. With this type of call, a caller will be required to enter an authorization code in order to access the customer's VPNS network. This type of call applies to traveling employees who might be accessing the VPNS remotely. Once the caller has been granted access to the VPNS, the private dialing plan can be used to complete the call.

Off-net to off-net - Calls originating and terminating in telephone numbers not included in the customer's private dialing plan database. This type of call applies to traveling employees who might be accessing the VPNS via a remote access mode. Once the caller has been granted access to the VPNS the call will be routed in the same manner as an On-net to Off-net call.

Facility Hubbing

Routing Pattern Control - enables the customer of record to pre-select the route (private facilities or public network) of outgoing, off-net calls based on the called party's telephone number, time-of-day and/or day-of-week.

Remote Access to Private Facilities - the capability for customer of record station lines (Centrex lines, PBX trunks, ISDN lines or POTS lines) to reach a remotely located private facility or group of facilities by dialing an access code.

Facility Termination - The capability for private facilities terminated in a central office to be accessed by remote VPNS users.

Call Screening Controls

Call Patterns Screening Controls - Customer defined calling privileges which allow for screening by called telephone number or NPA.

Time-of-day, day-of-week screening - permits the customer to restrict calling privileges based on the time-of-day and/or day-of-week.

Issued by authority of an Order of the Public Service Commission of West Virginia in Case No. _____ dated _____.

Virtual Private Network Service

B. REGULATIONS (Cont'd)

1. Explanation of Terms (Cont'd)

Remote Access

Work-at-Home - the ability for customer of record employees to use their residential telephones to originate business calls by dialing a predefined access code before initiating the call and having the associated usage billed directly to their office telephone number.

Business Travel - the ability for customer of record employees to use an off-net telephone to originate business calls by dialing a pre-defined access code and identification code before initiating the call and having the associated usage billed directly to their office telephone number.

Access Control - Security for access to specific facilities, to override station restrictions, or to access VPNS features, can be provided based on the calling number, an authorization code, a Personal Identification Number or a combination of the above.

Authorization Codes - Codes from 2 - 15 digits in length that can be used to validate access and/or calling privileges.

Personal Identification Number - Numbers that can vary in length from 4 - 8 digits that can be used to associate restricted services and privileges with employees and/or office telephone numbers.

Interactive Account Codes - Codes used by customer of record to track network usage and to bill back usage to a particular department or user.

Non-validated Account Codes - Codes assigned by customers to track and bill back to specific departments or clients. These codes are not verified as legitimate codes belonging to the customer i.e. any 1-8 digit code entered will be recorded.

Validated Account Codes - Codes assigned by customers to track and bill back to specific departments or clients. These codes are verified against legitimate codes as belonging to the customer.

Forced Account Codes - Enables a customer to require all originating calls to enter an account code prior to connecting the terminating end.

Virtual Hot Line Service - Allows for a predefined automatic connection from an on-net telephone to another on-net telephone at a remote location. When the receiver of the Virtual Hot Line Station is lifted, the telephone number of a pre-determined on-net station will be connected.

Issued by authority of an Order of the Public Service Commission of West Virginia in Case No. _____ dated _____.

Frontier West Virginia Inc.

Section 27
1st Revised Page 4
Cancels original Page 4

Virtual Private Network Service

B. REGULATIONS (Cont'd)

2. The contract lengths for VPNS must be the same in all locations. All features contracted for by the customer must have the same contract period, including those PNVS optional services added after the initial installation. (C)

In the event that the customer elects to disconnect any contracted features prior to the end of the subscribed contract period, the customer will be assessed a termination liability.

3. Customer defined access codes must be mutually agreed upon by the customer of record and the Company prior to installation of PNVS. Access Codes can vary in length from one to eleven digits. (C)
4. Authorization Codes and Personal Identification Numbers are administered and assigned by the customer. The customer must supply authorization codes and personal identification numbers to the Telephone Company prior to installation of PNVS. Authorization Codes can vary in length and must be at least two digits long and no longer than fifteen digits. (C)

Personal Identification Numbers can vary in length and must be at least four digits long and no longer than eight digits.

5. Termination Liability - A PNVS customer is liable for Termination charges for each and/or any of the subscribed PNVS services disconnected prior to the end of a contract period. Termination Liability will be calculated in the following manner: Twenty-five percent of the contract period's first full month's recurring charges of the services to be disconnected times the number of months remaining in the contract period. (C)
6. Access to Private Facilities can be provided to both one-way and two-way facilities. Customer defined access codes may vary in length from one to eleven digits.
7. Routing Control is available on outgoing off-net calls only. The traffic routing choices are provided by and the responsibility of the customer. There is a limit of three patterns per customer of record location.
8. Account Codes are administered and assigned by the customer. The customer must supply to the Telephone Company prior to installation of VPNS account codes which are to be validated. (C)

Non-validated Account Codes and Validated Account Codes may vary in length from one to eight digits.

9. Screening patterns are limited to three patterns per location.

Issued by authority of an Order of the Public Service Commission of West Virginia in Case No. 11-0799-T-T dated June 21, 2011.

Virtual Private Network Service

B. REGULATIONS (Cont'd)

10. Usage Charges

Usage charges may be billed as specified in the Local Exchange Services Tariff and the Long Distance Services Tariff.

11. Conditions

This service is offered subject to the following conditions:

- (a) Existing usage charges for message or intraLATA toll services apply to circuit switched voice calls.
- (b) This service is available only from central offices which have the necessary facilities to provide PNVS service. In the event that a customer is served by a non-conforming office, the Telephone Company may, at its option, provide PNVS service from an alternate serving central office at no additional charge to the customer. Such provisioning may be elected where, at the discretion of the Company, service can be provided at a reasonable cost to the Company. The customer must accept the serving location assigned by the Company, and must agree to revert to service from the normal serving central office at such time as VPNS service is available in that office. If PNVS service is provided from an alternate serving central office, the customer will accept a number change to one associated with the alternate serving central office. The customer will also be subject to calling areas associated with the alternate serving central office, as established in the Company's Tariffs. (C)

When PNVS service is available from the customer's normal serving central office, the customer will revert to and accept a number change that is associated with the original serving central office, and be subject to calling areas associated with the original serving central office, as specified in the Telephone Company's Tariffs. No charge will apply to the transfer of this service back to the serving central office as specified above. (C)

If the customer refuses to take service from the normal central office after such service becomes available, but continues to utilize service from the alternate serving central office, charges for foreign exchange and/or foreign central office service will apply, as specified in the Company's Tariffs.

Issued by authority of an Order of the Public Service Commission of West Virginia in Case No. 11-0799-T-T dated June 21, 2011.

GENERAL SERVICES TARIFF
P.S.C.-W.Va.-No. 203

Frontier West Virginia Inc.

Section 27
Original Page 6

Virtual Private Network Service

C. RATES

	Installation Charge	Per Month
1. Service Establishment Charge.....	\$ 500.00	-
2. Private Dialing Plan		
a. Location Code Dialing		
Month to month	2,000.00	\$300.00
12 - 23 months	2,000.00	285.00
24 - 35 months	2,000.00	270.00
36 + months	2,000.00	255.00
Additions or Changes, per occasion		
First 9 numbers	50.00	-
10 and over	50.00	-
b. Portable Extension Dialing		
Month to month	2,000.00	200.00
12 - 23 months	2,000.00	190.00
24 - 35 months	2,000.00	180.00
36 + months	2,000.00	170.00
Additions or Changes, per occasion		
First 9 numbers	50.00	-
10 and over	50.00	-
3. Facility Hubbing, per system		
a. Routing Pattern Control		
Month to month	2,000.00	400.00
12 - 23 months	2,000.00	380.00
24 - 35 months	2,000.00	360.00
36 + months	2,000.00	340.00
Additions, changes or deletions		
per route	50.00	-

Issued by authority of an Order of the Public Service Commission of West Virginia
in Case No. _____ dated _____.

GENERAL SERVICES TARIFF
P.S.C.-W.Va.-No. 203

Frontier West Virginia Inc.

Section 27
Original Page 7

Virtual Private Network Service

C. RATES (Cont'd)

	<u>Per Message</u>	<u>Installation Charge</u>	<u>Per Month</u>
3. Facility Hubbing (Cont'd)			
b. Remote Access to Private Facilities			
Per Facility Group			
Month to month		\$400.00	\$100.00
12 - 23 months		400.00	95.00
24 - 35 months		400.00	90.00
36 + months		400.00	85.00
c. Facility Terminations, per facility...		50.00	25.00
4. Call Screening Controls			
Call Patterns Screening.....		500.00	50.00
Time-of-day, day-of-week screening....		500.00	50.00
5. Remote Access*			
a. Work at Home			
per employee telephone number	\$.05	5.00	5.00
b. Business Travel, Remote access			
per employee account		5.00	5.00
per message	\$.05		

* Usage charges specified in B. preceding also apply.

Issued by authority of an Order of the Public Service Commission of West Virginia
in Case No. _____ dated _____.

Issued: January 8, 2001

Effective: January 8, 2001

GENERAL SERVICES TARIFF
P.S.C.-W.Va.-No. 203

Frontier West Virginia Inc.

Section 27
Original Page 8

Virtual Private Network Service

C. RATES (Cont'd)

	<u>Installation Charge</u>	<u>Per Month</u>
6. Access Control		
a. Authorization Code, per code.....	\$ 5.00	\$ 2.00
b. Personal Identification Number per PIN	5.00	2.00
c. Interactive Non-Validated Account Code....	5.00	2.00
d. Interactive Validated Account Code per code	5.00	3.00
e. Interactive Forced Account Code per code	5.00	3.00
7. Virtual Hot Line Service per line.....	25.00	25.00

Issued by authority of an Order of the Public Service Commission of West Virginia
in Case No. _____ dated _____.

Issued: January 8, 2001

Effective: January 8, 2001

Work-at-Home Billing Service

A. General

The Work-at-Home Billing Service (WAHBS) is a service purchased by a business for its employees to allow the use of their residential phone for business and automatically bill the calls to the business account.

B. REGULATIONS

1. WAHBS is subscribed to by the business. Residence clients may not purchase or modify this service for themselves. The business must provide to the Telephone Company the residence numbers that they wish equipped for this service. This service uses the physical line of the residence and no additional facilities are required.
2. The user at their residential phone dials an access code "*94" and receives second dial tone. The call is then dialed as a direct dialed call.
3. By subscribing to this service the business accepts the responsibility for charges originating from the Work-at-Home Charge Number at the residence. This number is a software number assigned to the residence line to distinguish business calls.
4. Incoming calls to this number are distinguished by a distinctive ring. Outgoing calls made with this service, i.e., after dialing "*94", will appear on the business account established for this service.
5. WAHBS is offered only where the residence location is served by a central office switch equipped with the Advanced Intelligent Network (AIN) and Common Channel Signaling/Signaling System 7 (CCS/SS7) architecture and software.
6. Although primarily for toll calls, local usage is billed at the appropriate measured rate charge.
7. Alternate selections for carriers through "10XXX" is not allowed.
8. Some usage plans may not be available with this service.
9. The company is not liable to the customer or any other person or entity for damages resulting from, or in connection with the provision of this service, including without limitation, the inability to access the operator or any telephone number.

C. RATES

1. Application of rates

- a. Installation charges are applicable for any addition, deletion, or changes to residence lines that the business wishes equipped for this service.
- b. In addition, normal service order charges apply.

	Installation Charge	Per Month
2. WAHBS, per residential line equipped.....	\$15.00	\$4.50

Issued by authority of an Order of the Public Service Commission of West Virginia
in Case No. _____ dated _____.

IP (INTERNET PROTOCOL) ROUTING SERVICE

A. GENERAL

IP (Internet Protocol) Routing Service (IPRS) provides for the collection, concentration and management of the customer's traffic within a LATA. IPRS consists of network routers located at LATA hub sites that will collect the customer's end user traffic and concentrate it for connection and transport over a Frontier Packet Data Service to a customer's designated location.

B. REGULATIONS

IPRS provides five types of ports for the collection of end user traffic. The port type(s) is/are determined by the method(s) chosen by the customer for access to its end user(s). The five port types are:

- 1) IPRS Combined Analog/ISDN Dial-up Port
- 2) IPRS ISDN Only Dial-up Port
- 3) IPRS DS-1/1.544 Mbps Port
- 4) IPRS Frame Relay Service (FRS) 56 Kbps Port (N)
- 5) IPRS Frame Relay Service (FRS) DS-1/1.544 Mbps Port (N)

The two dial-up types are intended for use with a single computer connection and are not for connection to a Local Areas Network (LAN).

IPRS does not include the end user access service. End user services and facilities are available from this and other pay telephone network tariffs.

IPRS requires the use of RADIUS (Remote Authentication Dial-In User Service), a network security protocol, for the customer's authentication and authorization of its dial-up end user(s).

Maintenance and upgrades for IPRS are performed during the hours of 11:00 p.m. and 8:00 a.m. At times, during the hours of maintenance activity, it will be necessary to place a customer's service in an inactive or out-of-service condition. The amount of time that this scheduled out-of-service condition will exist is called a "maintenance window." The Telephone Company will provide the customer notice prior to the maintenance window and will work cooperatively with the customer to minimize service disruption. Maintenance window activity could be scheduled for consecutive days.

IPRS is provided in compliance with standards established by the Internet Architecture Board as stated in the following publications:

STD 0001, Internet Official Protocol Standards; J. Postel, Editor, issued June 1997.

RFC 2138, Remote Authentication Dial-In User Service (RADIUS); C Rigney, A. Rubens, W. Simpson, S. Wilens., issued April 1997.

Issued by authority of an Order of the Public Service Commission of West Virginia in Case Numbers 00-1236-T-PC and 00-0995-T-PC Dated December 7, 2001.

Frontier West Virginia Inc.

Section 29
1st Revised Page 2
Cancels Original Page 2

IP (INTERNET PROTOCOL) ROUTING SERVICE

B. REGULATIONS (Cont'd)

Terms and Conditions

1. IPRS is a hubbed service. At least one wire center in each LATA is designated as a IPRS Hub. Customers' end users who use dedicated access must order their DS1 Special Access service to the customer's port in the IPRS LATA Hub.
2. Month-to-Month Service is subject to a minimum service period of 12 months.
3. IPRS is available on a month-to-month basis and for commitment periods of 3 years and 5 years. Combined Analog/ISDN Dial-up and ISDN Only Dial-up Port categories are only offered under a month-to-month service Plan.
4. IPRS is provided on a negotiated service date interval.
5. IPRS is monitored and maintained 24 hours-a-day 7 days-a-week for trouble isolation and resolution.
6. IPRS will be provided where technical capability exists.
7. IPRS customers must also subscribe to Verizon's SMDS, FRS, and/or ATM Service for the delivery of data traffic from the IPRS network to the customer's designated location. (N)
|
(N)

C. RATES

1. Application of Rates

- a. All rate categories are billed monthly.
- b. Non-recurring charges apply for the installation of each port. Changes in port from one rate category to another incur the non-recurring charge.

A conversion of service to a new commitment period of equal or greater length than the remainder of the existing term does not incur non-recurring charges for the existing port.

- c. When the customer's commitment period ends, month-to-month rates apply, unless the customer agrees to a new commitment period.

Issued by authority of an Order of the Public Service Commission of West Virginia in Case Numbers 00-1236-T-PC and 00-0995-T-PC Dated December 7, 2001.

IP (INTERNET PROTOCOL) ROUTING SERVICE

C. RATES (Cont'd)

1. Application of Rates (Cont'd)

- d. Termination liability applies when a port is disconnected prior to the end of the selected commitment period. Liability is assessed as follows:

Month-to-Month: The customer is responsible for 100% of the monthly rates for the entire commitment period.

3 and 5-year Terms: The customer is responsible for 100% of the monthly rate for the first 12 months and 15% of the remaining monthly charges.

Termination liability is waived if a port is converted to another term of equal or greater value in revenue than the remainder of the present term.

Termination liability is waived when a customer replaces one port for another type and commits to a term of equal or greater value in revenue than the remainder of the current commitment. The replacement is subject to applicable non-recurring charges.

- e. If the customer's Monthly Rate increases, the customer may discontinue service without liability.
- f. IPRS ports must be purchased in increments of 23 ports, except where available as single port quantities.

2. Rate Categories

- a. IPRS Combined Analog/ISDN Dial-up Port: provides one data path connection in a local calling area of the Company designated by the customer for analog/ISDN dial-up access to the customer by the customer's end users, and the IP routing of the end user data to the customer.
- b. IPRS ISDN Dial-up Port: provides one data path connection local calling area of the Company designated by the Customer for ISDN Primary Rate (PRI) dial-up access by the customer's end users, and the IP routing of the end user data to the customer.
- c. IPRS DS1/1.544 Mbps Port: provides connection and IP routing of end user data terminated at a speed of 1.544 Mbps.
- d. IPRS Frame Relay Service (FRS) 56 Kbps Port: Provides connection and IP routing of end user data terminated over frame relay facilities at a speed of 56 Kbps. (N)
- e. IPRS Frame Relay Service (FRS) DS-1/1.544 Mbps Port: Provides connection and IP routing of end user data terminated over frame relay facilities at a speed of 1.544 Mbps. (N)

Issued by authority of an Order of the Public Service Commission of West Virginia in Case Numbers 00-1236-T-PC and 00-0995-T-PC Dated December 7, 2001.

GENERAL SERVICES TARIFF
P.S.C.-W.Va.-No. 203

Frontier West Virginia Inc.

Section 29
1st Revised Page 4
Cancels Original Page 4

IP (INTERNET PROTOCOL) ROUTING SERVICE

C. RATES

3. Rates and Charges
- per port

<u>Port Category</u>	<u>Nonrecurring Charge</u>	<u>Monthly Rate (per Port)</u>	
1. Combined Analog/ISDN Dial-up Port Month-To-Month	\$ 34.78	\$ 59.00	
2. ISDN Only Port Month-To-Month	34.78	59.00	
3. DS-1/1.544Mbps Port Month-To-Month	200.00	175.00	
3 Year Service Period Plan	200.00	165.00	
5 Year Service Period Plan	200.00	150.00	
4. Frame Relay Service 56 Kbps Port Month-To-Month	200.00	45.00	(N)
3 Year Service Period Plan	200.00	30.00	
5 Year Service Period Plan	200.00	28.00	
5. Frame Relay Service DS-1/1.544 Mbps Port Month-To-Month	500.00	215.00	
3 Year Service Period Plan	500.00	200.00	
5 Year Service Period Plan	500.00	190.00	(N)

Issued by authority of an Order of the Public Service Commission of West Virginia in Case Numbers 00-1236-T-PC and 00-0995-T-PC Dated December 7, 2001.

Issued: December 17, 2001

Effective: January 1, 2002

ENHANCED DEDICATED SONET SERVICE

(N)

A. GENERAL

The Telephone Company's Enhanced Dedicated SONET Service (EDSS) is an optical high capacity service provided using SONET-based technology. EDSS is provided on SONET facilities except where a service is extended on an "off-net" facility.

EDSS provides the customer a dedicated high capacity customized network. The network is in a ring architecture or topology that assures greater survivability and can be arranged as a full ring, a partial ring, or a ring-on-ring topology that provides connectivity to multiple customer locations.

A full ring must have a minimum of three nodes with at least one of the nodes being located in a Telephone Company Central Office (CO) and one being located at a customer premises. The fiber path is such that when traversing the ring, the starting node and the end node are the same.

A partial ring must have a minimum of two nodes with at least one of the nodes being located in a CO and one being located at a customer premises. The customer premises node can be substituted with a high-speed interface if the customer circuits that are provisioned on the partial ring are connected in a CO. The fiber path is such that when traversing the ring, the starting node and the end node are different.

A ring-on-ring arrangement is a full ring riding over a larger full ring. The lower speed ring must have a minimum of two nodes with at least one of the nodes being located at a customer premises.

EDSS is an alternative to basic High Capacity point-to-point service between multiple customer locations. Monthly rate elements include ports, nodes, mileage and high-speed interfaces (certain partial ring configurations only). Rates are specified in Section D. following.

(N)

GENERAL SERVICES TARIFF
P.S.C.-W.Va.-No. 203

Frontier West Virginia Inc.

Section 30
Original Page 2

ENHANCED DEDICATED SONET SERVICE

(N)

B. DEFINITIONS

Add/Drop Multiplexing, (ADM): a multiplexing function that allows lower level signals to be added or dropped from an optical carrier channel.

Node: an EDSS rate element and a designation of either a customer location or CO on a SONET ring that has ADM capability. It is also the address of where a channelized (lower speed) service originates or terminates on a ring.

High Speed Interface: an EDSS rate element on a partial ring service that allows high-speed connection of the Company's facilities to the facilities of the customer or of a third party. High-speed connection is provided at a location that is mutually agreed upon by the Telephone Company and the customer.

Optical Carrier Rate, (OC #): a SONET transmission signal/speed, line rate, or service. The rates are in multiples of an OC1, which is equivalent to a STS1 (51.84 Mbps), SONET's basic rate.

<u>OC(#)</u> Rate	<u>Bandwidth Capacity</u>
3	155.52 Mbps
12	622.08 Mbps
48	2.488 Gbps
192	9.952 Gbps

Optical Carrier Rate Concatenated, (OC#c): a "clear channel" SONET transmission using only one framing format. Generally, an OC3 signal provides three STS1 frame formats with 3 overheads for a total capacity of 2268 bytes per Synchronous Payload Envelope (SPE) frame; in an OC3c signal, one STS3c frame format is used with one overhead, increasing the total payload capacity to 2340 bytes per SPE frame.

(N)

Issued by authority of an Order of the Public Service Commission of West Virginia
Case No. _____ dated _____.

Issued: June 11, 2004

Effective: July 12, 2004

ENHANCED DEDICATED SONET SERVICEN

(N)

B. DEFINITIONS (Cont'd)

OC12+3, OC48+3, OC192+3, OC192+12, and OC192+48: designations for nodes in ring-on-ring designs; the higher speed ADM is part of the true ring, and the lower speed ADM is connected for the purpose of mapping lower speed services onto the STS1s of the OC12, OC48 or OC192.

EDSS Port (Port): an EDSS rate element that denotes the interface at which a channelized or lower speed service terminates or originates at an EDSS node.

SONET, (Synchronous Optical Network): an international standard for the transmission of high capacity bandwidth over optical facilities. This synchronous transmission platform utilizes a modular multiplexing approach. Because of the large bandwidth, some of the payload is used to monitor, protect, manage and improve the transmission of the signal.

Synchronous Transport Signal Level, (STS1): a 51.84 Mbps signal that is the electrical equivalent of the OC1 or a DS3 with additional Mbps devoted to SONET overhead information. An STS1 can carry a DS3 or 28 DS1s when specifically formatted (mapped). These DS1s may be accessed off-ring using the tariffed DS3 to DS1 multiplexing optional service or via a DS3 Transmux port.

Transmuxing: the function of an EDSS DS3 Transmux port that performs a DS3 to DS1 conversion at an EDSS Node. The DS3 to DS1 conversion allows a single EDSS DS3 Transmux port to be associated with up to twenty-eight (28) VT1.5 mapped EDSS DS1 ports. Transmuxing within the EDSS network retains DS1 visibility allowing for proactive maintenance capability of DS1 signals.

Virtual Tributary, (VT): a SONET structure designed for transport of sub-STs1 payloads. A DS1 is mapped into the SONET format using a VT1.5 as a packaging mechanism that is internal to the SONET signal.

(N)

Issued by authority of an Order of the Public Service Commission of West Virginia
Case No. _____ dated _____.

ENHANCED DEDICATED SONET SERVICE

(N)

C. TERMS AND CONDITIONS

1. All Rings

When a customer premises node is located in the same building as a CO node, there may be less diversity between the two nodes.

When a customer transmits STS1, Internet Protocol or Ethernet signals, the mapping feature must be designated.

Ethernet services are provided on a point-to-point basis between two suitably equipped EDSS nodes.

Extended Superframe Format (ESF) is required on all DS1 circuits.

Generally, a transmission of 20 or more miles or a transmission through 6 or more COs will be subject to loss of signal integrity. Additional nodes may be added to maintain signal integrity.

The customer specifies the ring capacity in terms of optical carrier rates. EDSS is available in capacities of OC3, OC12, OC48 and OC192. Lower speed services are provided between nodes via ports.

EDSS is deployed upon customer request, and is available based on negotiated intervals. Where suitable SONET facilities are not available, Special Construction rates and charges may apply.

The customer must provide, at no cost to the Telephone Company, suitable and secure space, suitable environmental conditions, and uninterrupted power supply, building entrance facilities, and conduit for placement of the facilities and network equipment at its locations as necessary to provide the service.

One or more lower speed node(s) may subtend a higher speed node (e.g., an OC12 node may subtend an OC192 node). Rates and charges apply for both the higher speed node and for each subtending lower speed node provided. Additionally, the applicable port charge will apply to drop the lower speed channel that connects the higher speed node to the subtending lower speed node.

(N)

Issued by authority of an Order of the Public Service Commission of West Virginia
Case No. _____ dated _____.

ENHANCED DEDICATED SONET SERVICE

(N)

C. TERMS AND CONDITIONS (Cont'd)

2. Partial Ring

When EDSS is provided in a partial ring configuration, the following applies:

The customer must provide the Telephone Company with its fiber optic facility requirements (i.e., whether it will use single mode fiber or multi-mode fiber) prior to the Telephone Company ordering the necessary SONET network equipment to provide the requested service. The customer may utilize its own fiber optic facilities or the facilities of a third party.

When ordering lower speed channels that originate at and terminate to nodes that are not within the partial ring provided by the Telephone Company, the customer must provide the Telephone Company with a copy of the order the customer placed with the third party provider, to ensure technical compatibility for mapping channels between the service provided by the Telephone Company and the service provided by the third party. A Channel Mapping nonrecurring charge will apply for each channel mapped from the Telephone Company provided partial ring to the service provided by the third party. Channel mapping charges do not apply when ordering channels that originate at and terminate to nodes on the Telephone Company's portion of the partial ring.

Connection to Partial Ring Service:

The Telephone Company's network design will define the optical parameters at the connection locations. The Telephone Company is responsible for the optical parameters of the high-speed optical signal at the location where its facilities are connected to the facilities of the customer or of the third party. The Telephone Company bears no responsibility for the optical parameters beyond its location (i.e., in the facilities of the customer or of the third party). The customer or third party is responsible for engineering its portion of the jointly provided ring.

Connection to EDSS partial ring service is limited to high-speed fiber connection of the Telephone Company backbone network fiber optic facilities and the fiber optic facilities of the customer or of a third party. Partial ring service may only be connected to (1) another partial ring provided by the Telephone Company or (2) suitable ring facilities provided by the customer or third party. The portion of the ring provided by the customer or third party must use vendor equipment that matches the equipment used by the Telephone Company and must maintain the same vintage in software release as the Telephone Company. Upon written notice by the Telephone Company, the customer or third party will have sixty (60) days in which to complete the change-out of any software release deployed by the Telephone Company.

Connection to EDSS partial ring services may occur at the customer premises at which location the connection will occur via a node or at a mutually agreed upon location where connection occurs via a high-speed interface. Connection to other Telephone Company services may not occur at the mutually agreed upon high-speed interface. Such location will be designated as a customer premises for the purpose of administering the general regulations set forth in this tariff.

(N)

Issued by authority of an Order of the Public Service Commission of West Virginia
Case No. _____ dated _____.

ENHANCED DEDICATED SONET SERVICE

(N)

C. TERMS AND CONDITIONS (Cont'd)

3. Ring-on-Ring

When EDSS is provided in a ring-on-ring design, the following applies:

The lower speed ring must have a minimum of two nodes located at the customer premises or one node at the customer premises and one node at the CO.

The Telephone Company must provide the lower speed nodes.

Each lower speed node must subtend off of its corresponding higher speed node.

4. Ports

The type of ports that are supported on a node may limit the maximum number of ports that are provided on that node. Accepted port speeds are as follows:

Enhanced Nodes =	OC3	OC12	OC48	OC192
DS1 Ports	X	X	X	X
DS3 Ports	X	X	X	X
DS3 Transmux Ports	X	X	X	X
STS1 Ports	X	X	X	X
OC3 Ports		X	X	X
OC3c Ports		X	X	X
OC12 Ports			X	X
OC12c Ports			X	X
OC48 Ports				X
OC48c Ports				X
Ethernet Ports				
GigE-1 Ports		X	X	X
GigE-3 Ports		X	X	X
GigE-6 Ports		X	X	X
GigE-9 Ports		X	X	X
GigE-12 Ports			X	X
GigE-24 Ports			X	X

(N)

Issued by authority of an Order of the Public Service Commission of West Virginia
Case No. _____ dated _____.

ENHANCED DEDICATED SONET SERVICE

(N)

C. TERMS AND CONDITIONS (Cont'd)

4. Ports (Cont'd)

Changes in month-to-month ports are treated as disconnects and subsequent installations.

When High Capacity services are provided between two EDSS rings, the associated ports must be symmetrical. (e.g., DS1 Port to DS1 Port, DS3 Port to DS3 Port).

When a lower capacity service is dropped from an EDSS, the associated ports will be billed to the lower capacity service. Lower capacity services may not be dropped at locations utilizing a high-speed interface.

Ports may be ordered in a symmetrical arrangement (e.g., DS3 Port to DS3 Port), an asymmetrical arrangement (e.g., OC12 Port to DS3 Port) or in certain transmuxing arrangements as specified following. Ethernet ports may only be ordered in symmetrical arrangements. Ports are not provided at locations where a high-speed interface is utilized.

When transmuxing arrangements are ordered in symmetrical or asymmetrical port combinations, the following conditions apply:

- A DS1 port associated with a DS3 Transmux port may not coexist as a separate DS1 port with the same EDSS node.
- An end-to-end DS1 service provided over EDSS may not be associated with more than one DS3 Transmux port.
- DS3 Transmux ports are available at premises nodes or at CO nodes.
- The higher speed port of an asymmetrical port combination will be mapped based on the speed of the connecting service and port.

For all other asymmetrical port combinations, the following conditions apply:

- The higher speed port will be mapped based on the speed of the connecting service and port. The higher speed port is referred to as a Stub Hub Port in the arrangement.
- The Stub Hub Port is only available at a premises node.
- Stub Hubs Ports are not provided on partial ring configurations.
- The lower speed port(s) can be provided at customer premises and CO nodes.

(N)

Issued by authority of an Order of the Public Service Commission of West Virginia
Case No. _____ dated _____.

ENHANCED DEDICATED SONET SERVICE

(N)

C. TERMS AND CONDITIONS (Cont'd)

4. Ports (Cont'd)

- Asymmetrical ports are available in the following combinations:

<u>Node Speeds</u>		<u>Port Combinations</u>	
OC3 EDSS Ring	OC3 - OC3	STS1 - DS3	
OC12 EDSS Ring	OC12 - OC12	STS1 - DS3	
		OC3 - DS3	OC3 - STS1
		OC3 - DS1	
		DS3 - DS1	
OC48 EDSS Ring	OC48 - OC48	DS3 - DS1	
		OC3 - DS3	OC3 - STS1
		OC12 - DS3	OC12 - STS1
		OC12 - OC3	OC12 - OC3c
OC192 EDSS Ring	OC192 - OC192	DS3 - DS1	
		STS1- DS3	
		OC3 - DS3	OC3 - STS1
		OC12 - DS3	OC12 - STS1
		OC12 - OC3	OC12 - OC3c
		OC48 - DS3	OC48 - STS1
		OC48 - OC3	OC48 - OC3c
		OC48 - OC12	OC48 - OC12c

(N)

Issued by authority of an Order of the Public Service Commission of West Virginia
Case No. _____ dated _____.

ENHANCED DEDICATED SONET SERVICE

(N)

C. TERMS AND CONDITIONS (Cont'd)

5. Interfaces

EDSS is only available for the following interface combinations:

DS1 - DS1
DS1 - STS1
DS3 - DS3
DS3 - DS1
STS1 - STS1
OC3 - STS1
OC3 - OC3
OC3 w/DS3 mapping - DS3
OC3 w/DS1 mapping - DS1
STS1 w/DS3 mapping - DS3
STS1 w/DS1 mapping - DS1
OC3c - OC3c
OC12 - STS1, DS3, OC3, OC3c & OC12
OC12c - OC12c
OC48 - STS1, DS3, OC3, OC3c, OC12, OC12c & OC48
OC48c - OC48c
Gigabit Ethernet
GigE1 - GigE1 (mapped as 1 STS1 channel)
GigE3 - GigE3 (mapped as 3 STS1 channels or 1 STS3c channel)
GigE6 - GigE6 (mapped as 6 STS1 channels or 1 STS6c channel)
GigE9 - GigE9 (mapped as 9 STS1 channels or 1 STS9c channel)
GigE12 - GigE12 (mapped as 12 STS1 channels or 1 STS12c channel)
GigE24 - GigE24 (mapped as 24 STS1 channels or 1 STS24c channel)

6. Mileage

EDSS Mileage on a full ring is the total of airline distances between nodes rounded up to the nearest mile.

EDSS Mileage on a partial ring is the total of airline distances between connection locations and each node on the partial ring. The total mileage is then rounded up to the nearest mile.

The mileage rate is based on total ring capacity and not on individual services between nodes. For example, the mileage charge for a four-node OC3 ring with 5.1 miles between each node (20.4 total miles) would be calculated by multiplying the OC3 mileage rate by 21 miles. This mileage calculation applies regardless of the number of services (e.g., DS3s) on the ring.

(N)

Issued by authority of an Order of the Public Service Commission of West Virginia
Case No. _____ dated _____.

ENHANCED DEDICATED SONET SERVICE

(N)

C. TERMS AND CONDITIONS (Cont'd)

6. Mileage (Cont'd)

An example of a full Enhanced Dedicated SONET ring is diagrammed below:

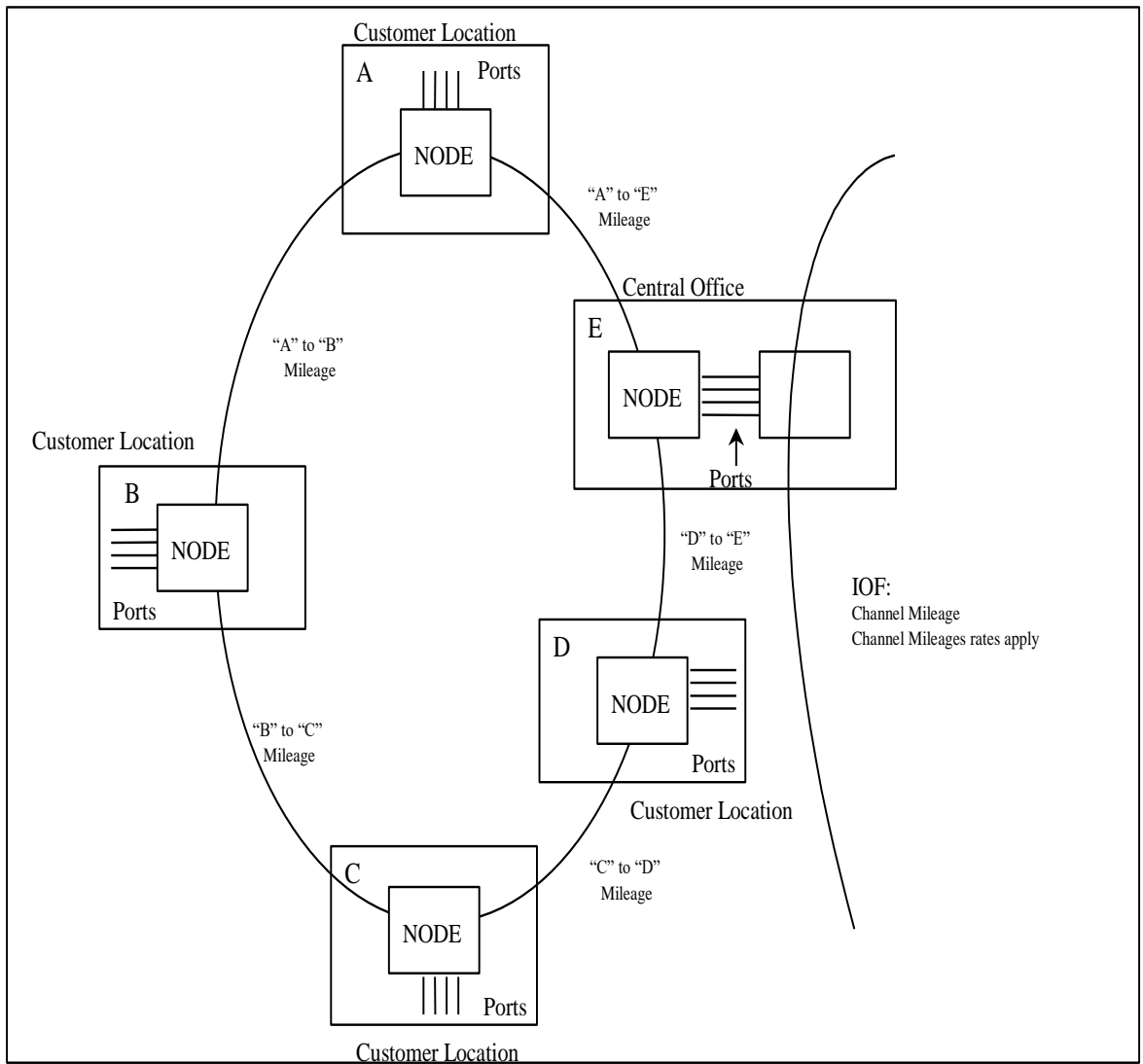

(N)

Issued by authority of an Order of the Public Service Commission of West Virginia
Case No. _____ dated _____.

ENHANCED DEDICATED SONET SERVICE

(N)

C. TERMS AND CONDITIONS (Cont'd)

6. Mileage (Cont'd)

An example of a partial Enhanced Dedicated SONET ring is diagrammed below:

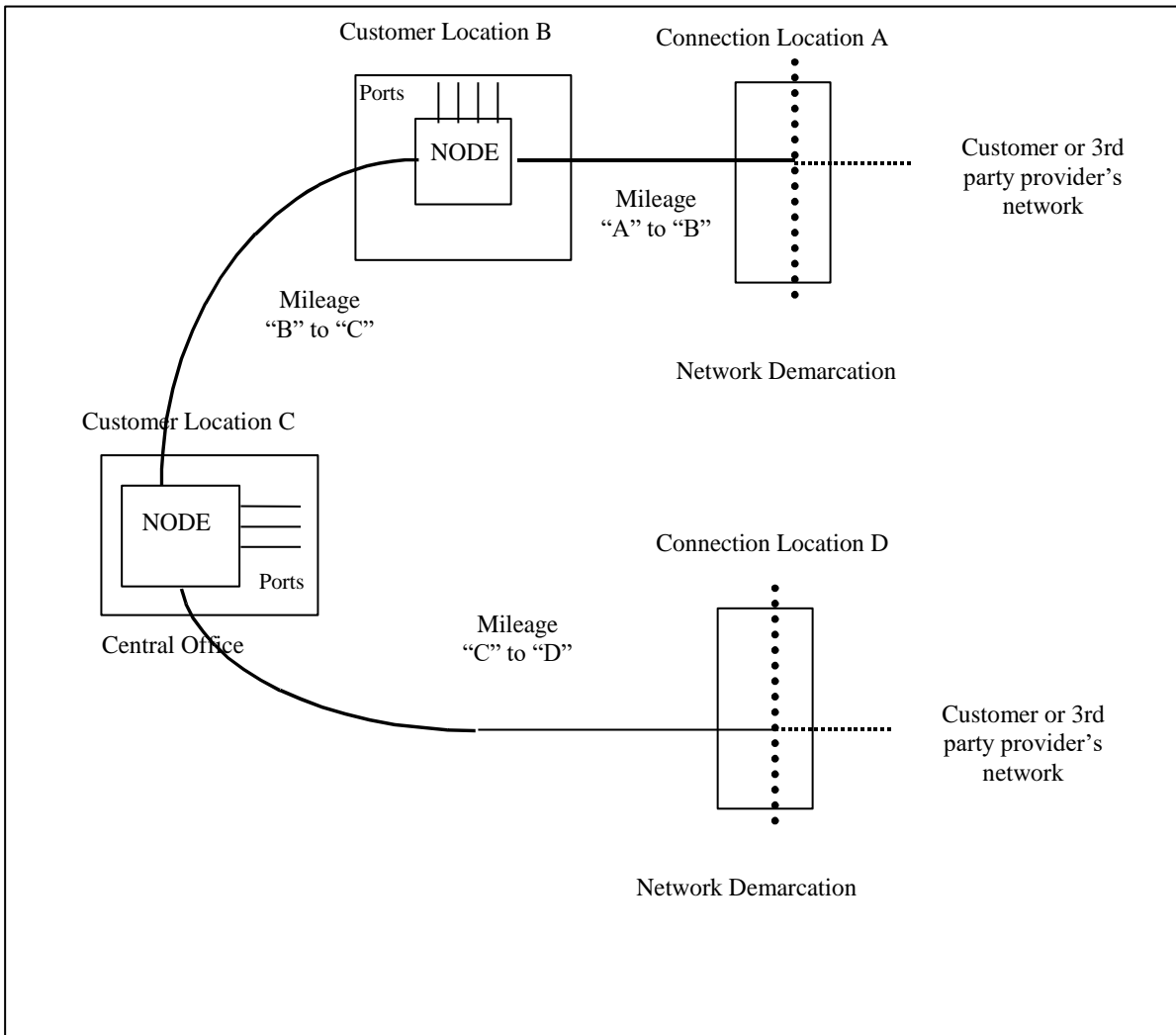

(N)

Issued by authority of an Order of the Public Service Commission of West Virginia
Case No. _____ dated _____.

ENHANCED DEDICATED SONET SERVICE

(N)

C. TERMS AND CONDITIONS (Cont'd)

7. Commitment Period

EDSS is available for 3, 5 and 7-year commitment periods, for ports, nodes, mileage and high-speed interfaces. Ports are also available on a month-to-month basis. Ports and nodes added subsequent to the initial installation may be coterminous to the expiration date of the EDSS provided the addition is prior to the 21st month for a 3-year plan, prior to the 36th month for a 5-year plan, or prior to the 50th month for a 7-year plan. Ports and nodes added after the aforementioned periods require extending the commitment period for an additional one-year for a 3-year plan, an additional 2 years for a 5-year plan, or an additional 3 years for a 7-year plan. Ports in a month-to-month plan may be added at anytime. The added nodes must be at the same or lower speed as the existing nodes.

Monthly recurring rates apply for the ports, nodes, mileage and high-speed interfaces. Once a term period expires, the prevailing rates of the current plan will continue until the customer cancels service or requests a new term plan.

Nonrecurring charges for ports apply on a first and additional basis. To qualify as first and additional, the ports must be like-ports (e.g., 2 DS1 ports) installed at the same node at the same time.

Nonrecurring charges apply to the initial installation of ports purchased on a month-to-month basis, and to subsequent installations of all ports and nodes.

(N)

Issued by authority of an Order of the Public Service Commission of West Virginia
Case No. _____ dated _____.

ENHANCED DEDICATED SONET SERVICE

C. TERMS AND CONDITIONS (Cont'd)

8. Termination Liability

Termination liability applies to EDSS service or an Optional Feature, and is charged per rate element on all ports, nodes, mileage high-speed interfaces and Optional Features, except month-to-month ports for which the one-month minimum service charge applies. (C)
| (C)

Termination liability will apply when the customer cancels service prior to expiration of the selected term, unless the exception conditions described below are met. If the cancellation occurs within the first two years of the term, termination liability is equal to 100 percent of the monthly charges for the unexpired portion of the first two years of the term, and 25 percent of the monthly charges for the remainder of the term. If the customer cancels after the first two years of service, then termination liability is equal to 25 percent of the monthly charges for the remainder of the term.

EDSS service or an Optional Feature may be canceled without termination liability when cancellation of the service occurs within thirty (30) days of the effective date of a Telephone Company initiated rate increase of eight percent (8%) or more on any rate applicable to EDSS service. (C)

Termination liability will not apply to EDSS service or Optional Feature if a customer changes to a longer-term commitment period, and the number of services or ports included in the new commitment period remains the same or increases. (C)

Termination liability will not apply to a customer upgrade (change to a higher capacity EDSS service) of an EDSS node or port, if all of the following conditions are met: (C)

- a. A new commitment period commences with the upgrade.
- b. The new expiration date must extend beyond the discontinued plan date.
- c. The new EDSS service is provided at the same customer and/or Telephone Company location(s) as the discontinued service plan.
- d. Additional nodes and ports added at the time of the upgrade incur all applicable rates and charges.

A customer can move a node from one location to another location without incurring termination liability providing that all of the following conditions are met:

- a. A new commitment period commences with the move.
- b. The new expiration date must extend beyond the discontinued plan date.
- c. The customer accepts a temporary interruption of the existing service in order to establish the new service.
- d. The new service is ordered at the same time as the service being disconnected.

Issued by authority of an Order of the Public Service Commission of West Virginia
Case No. _____ dated _____.

ENHANCED DEDICATED SONET SERVICE

(N)

C. TERMS AND CONDITIONS (Cont'd)

8. Termination Liability (Cont'd)

For EDSS with a commitment period which was extended under 10. following, termination liability is calculated as the difference between the monthly rates for the highest commitment period that could have been satisfied prior to disconnection of the service or cancellation of the plan and the monthly rates for the extended commitment period for the period of time the service was in effect.

9. Conversions

Customers who wish to move or convert existing High Capacity services to an EDSS may do so without conversion charges (termination liability and installation charges) as long as the total capacity of services purchased by the customer does not decrease.

10. Extension of a Commitment Period

For EDSS the customer also has the option, within sixty (60) days prior to the expiration date for its commitment period, to extend its expiring term plan to a plan with a longer commitment period. The commitment period selected for the extended plan must be longer than the commitment period of the expiring plan as follows:

- An expiring 3-Year Term may be extended to either a 5-Year or 7-Year Term Plan.

- An expiring 5-Year Term may be extended to a 7-Year Term Plan.

Time-in-service credit on the expiring plan will be granted and applied towards the new extended plan. For example, an expiring 3-Year term plan will allow for 3 years of time-in-service credit towards a 5-Year or 7-Year extended plan.

The discount percentage associated with the extended plan will apply effective with the first bill date following expiration of the commitment period for the existing plan and will continue through the remainder of the commitment period associated with the extended plan. No adjustment for the increased discount percentage associated with the extended plan will be made to the monthly rates already billed on the expiring plan.

(N)

ENHANCED DEDICATED SONET SERVICE

(N)

C. TERMS AND CONDITIONS (Cont'd)

11. When a Credit Allowance Applies

EDSS is guaranteed service restoral within one minute in the event of a service interruption except as specified in 12 following. Any service interruption greater than one minute due solely to a Telephone Company facility failure will result in a credit allowance of 100% of the monthly rate for the applicable rate elements of the affected service, provided that the interruption is brought to the attention of the Telephone Company within 10 days. The total credit allowance in any one billing period cannot exceed 100% of the customer's monthly rate for the affected rate elements, regardless of the number or length of service interruptions within a billing month.

12. When a Credit Allowance Does Not Apply

No credit allowance will be made for:

- a. Service interruptions of less than one minute.
- b. Service interruptions caused by the negligence of the customer or authorized user.
- c. Service interruptions resulting from the failure of equipment or systems provided by the customer or authorized user.
- d. Service interruptions during any period in which the Telephone Company is not afforded access to a premises for testing and/or repair of service.
- e. Service interruptions when the customer has released the service to the Telephone Company for maintenance purposes, to make rearrangements, or for the implementation of an order for a change in the service during the time that was negotiated with the customer prior to the release of that service.
- f. Service interruptions which continue due to the failure of the customer to authorize replacement of any element of special construction. The period during which no credit allowance will be made begins on the seventh day after the customer receives the Telephone Company's notification of the need for replacement and ends on the day after the Telephone Company receives the customer's authorization for replacement.
- g. Service interruptions during periods when the customer elects not to release the service for testing and/or repair.
- h. Service interruptions during periods when the customer or user has released the service for rearrangement purposes or for the implementation of a customer order.

(N)

Frontier West Virginia Inc.

Section 30
1st Revised Page 14.2
Cancels Original Page 14.2

ENHANCED DEDICATED SONET SERVICE

D. OPTIONAL FEATURES

1. Customer Service Management Optional Feature (CSM)

a. Description

CSM provides a customer with real-time information about the operational status of its EDSS network. Two (2) Service Levels of support are offered for CSM. Each Service Level provides different functionalities to which the customer may gain access. These functionalities are described following and include access to real-time information about the customer's EDSS network and the ability to generate reports. When ordering CSM, the customer must specify one of the following two Service Levels. (C)

1. Level 1 - provides a network view of real-time detection and reporting of network alarm conditions within the customer's EDSS network. (C)
2. Level 2 - provides the same capabilities described in Level 1 along with the ability for the customer to generate basic network performance reports for its EDSS network. The customer may also request network performance reports that are customized to meet their specific needs. (C)

(D)

(D)

Issued by authority of an Order of the Public Service Commission of West Virginia
Case No. _____ dated _____.

GENERAL SERVICES TARIFF
P.S.C.-W.Va.-No. 203

Frontier West Virginia Inc.

Section 30
1st Revised Page 14.2a
Cancels Original Page 14.2a

ENHANCED DEDICATED SONET SERVICE

D. OPTIONAL FEATURES (Cont'd)

1. Customer Service Management Optional Feature (CSM) (Cont'd)

(D)

(D)

b. Terms and Conditions

1. The customer must utilize Internet web access to connect its customer-provided terminal equipment to the Telephone Company's CSM management system. Access to the Internet and any associated rates and charges are the responsibility of the customer. The customer is also responsible for obtaining communications software that is compatible with the software the Telephone Company utilizes to provide CSM. The Telephone Company will work cooperatively with the customer to determine compatibility of its communications software.
2. CSM is provided only when the Telephone Company provides all nodes on the ring.

Issued by authority of an Order of the Public Service Commission of West Virginia
Case No. _____ dated _____.

ENHANCED DEDICATED SONET SERVICE

D. OPTIONAL FEATURES (Cont'd)

1. Customer Service Management Optional Feature (CSM) (Cont'd)

b. Terms and Conditions (Cont'd)

3. Subject to the restrictions set forth in Section D.4. following, CSM is provided coincident with the installation of the associated EDSS ring or may be added to an existing ring. An Initial CSM Setup charge applies for establishment of the customer's initial CSM database partition. The initial CSM database partition includes setup for up to six (6) users.
4. CSM Service Level is provided under a term plan of 3 years, 5 years, or 7 years, as described following.
 - a. The duration of the term plan for CSM Service Level must be the same duration as the term plan for the EDSS nodes provided with CSM. At the expiration of its 3, 5, or 7 year term plans or CSM Service Levels or Preplanned Ports, the customer has the option of extending CSM Service Level with a coterminous end date as described in Section b. following. (C)
 - b. The expiration date of each CSM Service Level added subsequent to the initial installation must be coterminous to the expiration date of the associated EDSS service, provided that the addition is prior to the 21st month for a 3-year plan, prior to the 36th month for a 5-year plan, or prior to the 50th month for a 7-year plan. A CSM added after the aforementioned periods requires extension of the commitment period for the associated EDSS service in accordance with this Section (a.) preceding. Such extension results in the establishment of a new plan that includes both the EDSS and the CSM under the same plan with the same expiration date. (C)
5. With Service Level 2 support, the customer may retrieve certain basic reports containing performance-monitoring information on its EDSS network, as designated and provided by the Telephone Company. Basic reports are available at no additional charge to the customer. The customer may also request that a report be customized to meet its particular needs. Rates and charges for customized reports are provided on a special assembly basis. Reports are not provided with Level 1 support. (C)
6. CSM is subject to termination liability if CSM is removed prior to completion of the existing commitment period. The terms and conditions in Section 30.C.8 proceeding, as applicable, apply to removal of CSM prior to completion of the existing commitment period.

Issued by authority of an Order of the Public Service Commission of West Virginia
Case No. _____ dated _____.

Frontier West Virginia Inc.

Section 30
1st Revised Page 14.2c
Cancels Original Page 14.2c

ENHANCED DEDICATED SONET SERVICE

D. OPTIONAL FEATURES (Cont'd)

1. Customer Service Management Optional Feature (CSM) (Cont'd)

c. Application of Rates and Charges

1. CSM rates and charges are set forth in Section E, unless noted otherwise. CSM rates and charges apply in addition to any applicable EDSS rates and charges. Unless otherwise indicated below, CSM rates and charges apply regardless of the Service Level selected by the customer.

For monthly recurring charges a CSM Service Level monthly recurring charge applies for each EDSS ring provided with CSM.

(D)
|
(D)

2. Nonrecurring Charges - Apply as follows:

- a. A Node Setup charge applies for each node that is equipped with CSM at the time that CSM is initially established on the ring.
- b. An Add/Remove Node charge applies for each node that is subsequently added to, or removed from, a ring that has already been equipped to provide CSM.
- c. An Initial CSM Setup charge applies for establishment of the customer's initial CSM database partition. The initial CSM database partition includes setup for up to six (6) users.
- d. A Setup of Additional Users charge applies for the setup of up to six (6) additional users beyond those provided with the initial database setup when CSM is initially established on the ring.
- e. A Setup of Additional Partition or Change in CSM Service Level charge applies for the setup of an additional CSM database partition created for the same customer or to change from one CSM service level to another (e.g., change Service Level 1 to Service Level 2). Each additional CSM database provides for the setup of up to six (6) additional users.

(C)
(C)

Issued by authority of an Order of the Public Service Commission of West Virginia
Case No. _____ dated _____.

GENERAL SERVICES TARIFF
P.S.C.-W.Va.-No. 203

Frontier West Virginia Inc.

Section 30
1st Revised Page 14.2d
Cancels Original Page 14.2d

ENHANCED DEDICATED SONET SERVICE

D. OPTIONAL FEATURES (Cont'd)

1. Customer Service Management Optional Feature (CSM) (Cont'd)

c. Application of Rates and Charges (Cont'd)

2. Nonrecurring Charges (Cont'd)

- f. A Consultation and Support charge applies for each thirty (30) minutes or fraction thereof that the customer requests Telephone Company consultation and support of its CSM network. This charge does not apply during initial setup of CSM on the ring.

(D)

(D)

Issued by authority of an Order of the Public Service Commission of West Virginia
Case No. _____ dated _____.

Issued: April 14, 2006

Effective: April 30, 2006

GENERAL SERVICES TARIFF
P.S.C.-W.Va.-No. 203

Frontier West Virginia Inc.

Section 30
1st Revised Page 15
Cancels Original Page 15

ENHANCED DEDICATED SONET SERVICE

E. RATES

(C)

1. Monthly Rates per Node

<u>Node Type</u>	<u>Rate</u>
OC3	ICB
OC12	ICB
OC48	ICB
OC192	ICB

2. Node Nonrecurring Charges ICB

3. Monthly Mileage Rates

<u>Ring Type</u>	
OC3	ICB
OC12	ICB
OC48	ICB
OC192	ICB

4. Monthly Port Rate per Node

<u>Port Type</u>	
DS1	ICB
DS3 or STS1	ICB
DS3 or Transmux	ICB
OC3	ICB
OC3c	ICB
OC12	ICB
OC12c	ICB
OC48	ICB
OC48c	ICB
GigE1	ICB
GigE3	ICB
GigE6	ICB
GigE9	ICB
GigE12	ICB
GigE24	ICB

Issued by authority of an Order of the Public Service Commission of West Virginia
Case No. _____ dated _____.

GENERAL SERVICES TARIFF
P.S.C.-W.Va.-No. 203

Frontier West Virginia Inc.

Section 30
1st Revised Page 16
Cancels Original Page 16

ENHANCED DEDICATED SONET SERVICE

E. RATES (Cont'd)

(C)

	<u>Rate</u>
5. Port Nonrecurring Charges	
Initial installations, Month-to-Month ports	ICB
Subsequent installation, all ports	ICB
6. Monthly Partial Ring High-Speed Interface	
<u>Ring Type</u>	
OC12	ICB
OC48	ICB
OC192	ICB
7. Partial Ring Channel Mapping NRC	
<u>Channel Type</u>	
DS1	ICB
DS3 or STS1	ICB
OC3	ICB
OC3c	ICB
OC12	ICB
OC12c	ICB
OC48	ICB
OC48c	ICB
GigE1	ICB
GigE3	ICB
GigE6	ICB
GigE9	ICB
GigE12	ICB
GigE24	ICB

Issued by authority of an Order of the Public Service Commission of West Virginia
Case No. _____ dated _____.

Issued: January 17, 2006

Effective: February 1, 2006

GENERAL SERVICES TARIFF
P.S.C.-W.Va.-No. 203

Frontier West Virginia Inc.

Section 30
1st Revised Page 17
Cancels Original Page 17

ENHANCED DEDICATED SONET SERVICE

E. RATES

<u>Monthly Rate Elements</u>	<u>3-year Rate</u>	<u>5-Year Rate</u>	<u>7-Year Rate</u>	
8. EDSS CSM Service Levels				(C)
Level 1	ICB	ICB	ICB	
Level 2	ICB	ICB	ICB	(D)
				(D)
				(D)
9. EDSS CSM Non Recurring Charges				(C)
Node Setup per node on the ring - NRC	ICB	ICB	ICB	
Initial CSM Setup - first Partitions with up to 6 users All Service Levels- Each NRC -	ICB	ICB	ICB	
Set up of Additional Partitions Or change in CSM Service level Each NRC -	ICB	ICB	ICB	
Set up of Additional Users up To 6 additional users - all Service levels - Each NRC	ICB	ICB	ICB	
Add/Remove Node, per node-NRC	ICB	ICB	ICB	(D)
				(D)
Consultation and Support each 30 Minutes or fraction thereof	ICB	ICB	ICB	
				(D)
				(D)

Issued by authority of an Order of the Public Service Commission of West Virginia
Case No. _____ dated _____.

SONET POINT-TO-POINT SERVICE

(N)

A. GENERAL

SONET Point-to-Point Service (SPTP) service provides high speed, synchronous optical fiber-based, full duplex data transmission capabilities. SPTP is provisioned over the Telephone Company's SONET network and provides customers with SONET based broadband transport with the following capabilities.

- | | |
|----------------------|---|
| OC3, OC3c or STM - 1 | Transmission services operating at the bit rate of 155.52 Mbps. |
| OC12, OC12c | Transmission services operating at the bit rate of 622.08 Mbps. |
| OC48, OC48c | Transmission services operating at the bit rate of 2.488 Gbps. |

B. DEFINITIONS

SPTP provides transport at the optical level between a customer's locations or between a customer's premises and a Telephone Company wire center, where it connects with another service of equal speed.

SPTP is transported over a shared network infrastructure and remains optical throughout the path. Depending on the service rate (payloads consisting of 3, 12, or 48 separate Synchronous Transport Signals (STS1s) with OC3, OC12, or OC48), separate overheads are transported. SPTP service is also offered in a concatenated format (one single channel with one single overhead) at service rates of OC3c, OC12c, and OC48c.

The same payload content is maintained throughout the service (i.e. if DS1s are mapped by the customer at one end, DS1s must be mapped at the other end of the service). SONET equipment is required throughout the circuit.

The service is available at month-to-month, and 3-year and 5-year term pricing plans. A 12-month minimum billing period applies. Month-to-month, 3-year and 5-year term pricing plan rates are not fixed and will vary based upon the rates in effect in the tariff.

Monthly rate elements consist of Local Distribution Channels ("LDC") and Channel Mileage, fixed and variable.

The technical specifications for SPTP service are delineated in Technical Reference GR-253-CORE, Issue 3. When provided with Synchronous Transport Module (STM-1) transmission, the technical specifications are delineated in Technical References ITU G707, ITU G708 and ITU G709.

(N)

Issued by authority of an Order of the Public Service Commission of West Virginia
Case No. _____ dated _____.

SONET POINT TO POINT SERVICE

(N)

B. DEFINITIONS (Cont'd)

SPTP services may be configured as follows:

- OC3 3 STS1 channels each of which may consist of:
 - a DS3 that is STS1 mapped
 - up to 28 DS1s that are Virtual Tributary (VT) mapped
 - an STS1 channel without constraint to payload mapping
- OC3c A single concatenated STS3c channel
- STM1 Synchronous Digital Hierarchy (SDH) channel of 155.52 Mbps
- OC12 12 STS1 channels each of which may consist of:
 - a DS3 that is STS1 mapped
 - up to 28 DS1s that are VT mapped
 - an STS1 channel without constraint to payload mapping
- OC12c A single concatenated STS12c channel
- OC48 48 STS1 channels each of which may consist of:
 - a DS3 that is STS1 mapped
 - up to 28 DS1s that are VT mapped
 - an STS1 channel without constraint to payload mapping; or

 16 separate concatenated STS3c channels; or
 4 separate concatenated STS12c channels; or
 any combination of the above configurations up to the total OC48
 capacity
- OC48c A single concatenated STS48c channel

(N)

SONET POINT-TO-POINT SERVICE

(N)

C. TERMS AND CONDITIONS

All rate elements associated with an SPTP service that is provided on a point-to-point basis between customer designated premises must be in the same rate plan.

When SPTP is ordered with STM transmission, both of the customer-designated premises must use STM transmission.

SPTP is deployed upon customer request, and is available based on negotiated installation intervals. Where suitable SONET facilities are not available, special construction rates and charges may apply.

The customer must provide, at no cost to the Telephone Company, suitable and secure space, suitable environmental conditions and uninterrupted power supply, building entrance facilities and conduit for placement of the facilities and network equipment at its locations as necessary to provide the service.

SPTP services, which are provided on a month-to-month basis, are subject to a one-year minimum service requirement. If service is disconnected during the first year, the minimum period charge is 100% of the monthly rate from the date of disconnection through the end of the first year.

SPTP services which are provided under 3-year or 5-year term plans are subject to termination liability if service is disconnected prior to the end of the term plan.

1. Termination charges

- a. If the disconnect occurs during the first year of service, termination liability is calculated at 100% of the monthly charges for the unexpired portion of the first year, and at 15% of the monthly charges for the remainder of the term plan.
- b. If the disconnect occurs after the first year of service, termination liability is calculated at 15% of the monthly charges from the date of disconnection through the remainder of the term plan.

2. Termination liability will not apply:

- a. When cancellation of the SPTP service occurs within thirty-days of the effective date of a Telephone Company initiated rate increase and the customer's total monthly rate for the affected service increased by 8% or more.
- b. When the service is changed to a longer SPTP term plan.
- c. When the service is changed to an SPTP service of a higher bit rate with a new, equal or longer, term plan.
- d. When the service is converted to Enhanced Dedicated SONET Service.

(N)

Issued by authority of an Order of the Public Service Commission of West Virginia
Case No. _____ dated _____.

SONET POINT TO POINT SERVICE

(N)

C. TERMS AND CONDITIONS (Cont'd)

3. Expiration

At the expiration of a 3-year or 5-year term plan, the rates for the expiring term plan will continue until the customer either cancels service or orders a new plan.

A change in port or channel termination will be treated as a discontinuance of the existing service and an installation of a new service. All associated nonrecurring charges will apply for the new service. A new minimum period will be established for the new service. The customer will also be responsible for all outstanding minimum service period obligations associated with the disconnected service.

4. Credit Allowance

Any single service outage of four hours or more due solely to a Telephone Company facility failure will result in a credit of 100% of the monthly rate for the applicable rate elements affected, provided that the interruption is brought to the attention of the Telephone Company within 10 days. The total credit allowance in any one billing period cannot exceed 100% of the customer's monthly rate for the affected rate elements, regardless of the number or length of service interruptions within a billing month.

5. When credit allowance does not apply:

- a. Service interruptions of less than four hours.
- b. Service interruptions caused by the negligence of the customer or authorized user.
- c. Service interruptions resulting from the failure of equipment or systems provided by the customer or authorized user.
- d. Service interruptions during any period in which the Telephone Company is not afforded access to premises for testing and/or repair of service.
- e. Service interruptions when the customer has released the service to the Telephone Company for maintenance purposes, to make rearrangements, or for the implementation of an order for a change in the service during the time that was negotiated with the customer prior to the release of that service.
- f. Service interruptions that continue due to the failure of the customer to authorize replacement of an element of special construction; and
- g. Service interruptions during periods when the customer elects not to release the service for testing and/or repair.

(N)

Issued by authority of an Order of the Public Service Commission of West Virginia
Case No. _____ dated _____.

GENERAL SERVICES TARIFF
P.S.C.-W.Va.-No. 203

Frontier West Virginia Inc.

Section 30A
Original Page 5

SONET POINT TO POINT SERVICE

(N)

D. RATES

	<u>Monthly Rate Elements</u>	<u>Month to Month</u>	<u>3-year Rate</u>	<u>5-Year Rate</u>
1.	Local Distribution Channel (LDC) - 2 Fiber Port			
	OC3	ICB	ICB	ICB
	OC3c	ICB	ICB	ICB
	OC12	ICB	ICB	ICB
	OC12c	ICB	ICB	ICB
	OC48	ICB	ICB	ICB
	OC48c	ICB	ICB	ICB
2.	Local Distribution Channel (LDC) - 4 Fiber Port			
	OC3	ICB	ICB	ICB
	OC3c	ICB	ICB	ICB
	OC12	ICB	ICB	ICB
	OC12c	ICB	ICB	ICB
	OC48	ICB	ICB	ICB
	OC48c	ICB	ICB	ICB
	<u>Channel Mileage</u>	<u>Month to Month</u>	<u>3-year Rate</u>	<u>5-Year Rate</u>
1.	Fixed			
	OC3, OC3c	ICB	ICB	ICB
	OC12, OC12c	ICB	ICB	ICB
	OC48, OC48c	ICB	ICB	ICB
2.	Per Mile			
	OC3, OC3c	ICB	ICB	ICB
	OC12, OC12c	ICB	ICB	ICB
	OC48, OC48c	ICB	ICB	ICB

(N)

Issued by authority of an Order of the Public Service Commission of West Virginia
Case No. _____ dated _____.

GENERAL SERVICES TARIFF
P.S.C.-W.Va.-No. 203

Frontier West Virginia Inc.

Section 30A
Original Page 6

SONET POINT-TO-POINT SERVICE

(N)

D. RATES

	<u>Nonrecurring Rate Elements</u>	<u>Month to Month</u>	<u>3-year Rate</u>	<u>5-Year Rate</u>
1.	Local Distribution Channel (LDC) - 2 Fiber Port			
	OC3	ICB	ICB	ICB
	OC3c	ICB	ICB	ICB
	OC12	ICB	ICB	ICB
	OC12c	ICB	ICB	ICB
	OC48	ICB	ICB	ICB
	OC48c	ICB	ICB	ICB
2.	Local Distribution Channel (LDC) - 4 Fiber Port			
	OC3	ICB	ICB	ICB
	OC3c	ICB	ICB	ICB
	OC12	ICB	ICB	ICB
	OC12c	ICB	ICB	ICB
	OC48	ICB	ICB	ICB
	OC48c	ICB	ICB	ICB

(N)

Issued by authority of an Order of the Public Service Commission of West Virginia
Case No. _____ dated _____.

Frontier West Virginia Inc.

Section 31
2nd Revised Page 1
Cancels 1st Revised Page 1

BUSINESS TRAFFIC STUDY SERVICE

A. GENERAL

Business Traffic Study Service provides performance reports of call capacity for originating and terminating traffic on access lines or hunt groups. The traffic study report enables business customers to determine how many calls terminate successfully as opposed to the number of calls that reach a station-busy condition.

B. REGULATIONS

1. Traffic studies are performed, at the customer's request, on Telephone Company access lines or hunt groups with local exchange numbers.
2. For customers with access lines or hunt groups at more than one location, a separate non recurring charge would apply for traffic studies at each location.
3. Traffic study reports may be requested for more than one access line or hunt group at a single customer location. A separate traffic study report is required for each access line or hunt group. Following is a list of possible access lines or hunt groups that would constitute one traffic study report:

Business Lines/Trunks	Centrex Service
Multiline Hunt Group	Centrex Communications System
Dedicated BRI ¹	Remote Call Forwarding
Dedicated PRI	Features Plan - Business

(C)

4. Traffic study reports can be requested on a weekly, bi-weekly or monthly basis. The monthly rate is determined by the number of traffic study reports provided within a 4-week billing cycle.
5. Along with the reports, the Company provides a recommendation of required lines to accommodate the studied call traffic based on industry standards for call traffic handling. Calculations for the recommendation are derived from traffic engineering tables. The recommendation is a close estimate and cannot be guaranteed.
6. Calls must be carried by the Company and billed by or on behalf of the Telephone Company to the customer requesting the study.
7. Studies cannot be performed on toll-free or pay-per-call type telephone numbers.
8. A one-week traffic study may be performed per customer location, per calendar year, at no non recurring charge and no monthly charge. Any additional traffic studies requested during the calendar year will be billed at the Rates specified in C. following.
9. Traffic study report features may vary by Central Office switching system type.
10. For the setup of each additional Traffic Study, per customer location, per calendar year, the non recurring charge applies in addition to the Monthly Rate.

Applicable Service Order charges will apply in addition to the Service Establishment Charge for initial setup and for any subsequent additions or changes to Traffic Study Reports in a calendar year.

¹ ISDN-BRI is grandfathered and limited to existing customers at existing locations as of March 18, 2022. Moves, additions or changes will not be permitted.

(N)
(N)

GENERAL SERVICES TARIFF
P.S.C.-W.Va.-No. 203

Frontier West Virginia Inc.

Section 31
Original Page 2

BUSINESS TRAFFIC STUDY SERVICE

(N)

C. RATES

	<u>Nonrecurring Charge</u>	<u>Monthly Rate</u>	
Traffic Study Reports			
per access line or hunt group, per calendar year			
Initial one-week study report	no charge	no charge	
Additional one-week study report	\$120.00	no charge	
Each additional study report			
per 4-week billing cycle			
Weekly reporting (4 reports)	120.00	\$80.00	
Bi-weekly reporting (2 reports)	120.00	60.00	
Monthly reporting (1 report)	120.00	40.00	(N)

Issued by authority of an Order of the Public Service Commission of West Virginia
Case No. _____ dated _____.

GENERAL SERVICES TARIFF
P.S.C.-W.Va.-No. 203

Frontier West Virginia Inc.

Section 32
2nd Revised Page 1
Cancels 1st Revised Page 1

UNLIMITED LOCAL USAGE FOR BUSINESS

A. GENERAL

Unlimited Local Usage for Business is an optional calling plan which includes unlimited local voice usage for a flat monthly rate. Unlimited Local Usage for Business is available only to business customers with Business exchange service and/or Communications System Service, as set forth below. The Exchange Access line rate is not included in the Unlimited Local Usage for Business rate. (C)

B. REGULATIONS

1. Unlimited Local Usage for Business is available on Business exchange service, and Communications System lines where facilities permit. (C)
2. Unlimited Local Usage for Business is available only to customers who subscribe to the Telephone Company as their carrier for all local and intraLATA toll calls.
3. Unlimited Local Usage for Business applies per telephone line.
4. Unlimited Local Usage for Business is available to business customers who, at the time of initiation of service, subscribe to 25 or fewer Telephone Company lines (voice grade or voice grade equivalent) per customer location.
5. Eligible business customers may subscribe to the Unlimited Local Usage for Business plan for a maximum of ten (10) lines per customer location.
6. Unlimited Local Usage for Business is not available with Flexible Digital Channel Service, Digital Service -Voice, LD and Internet, PBX trunks, ground start lines or trunks, ISDN Basic Service, ISDN Primary Service, Remote Call Forwarding Service, Foreign Exchange Service, Public Telephone Service, Foreign Central Office Service, and Foreign Zone Service. (C)
7. Unlimited Local Usage for Business is not available with the following business packages or optional plans: Business Optional Calling Plan, Business Special Toll Plan, Company Rewards, Customer Specific Pricing Plans (CSP), grandfathered Optional Discount Term Plan, and Virtual Private Network Service. (C)
8. Unlimited Local Usage for Business does not apply to the following calls and services: (C)

All Other Operator Handled Calls Busy Line Verification Busy Redial, *69, Call Trace (per activation) Collect Calls Calling Card Directory Assistance Directory Assistance Call Completion Emergency Interrupt 555, 700, 900, 976 Service (Audiotex)	Group Bridge Service Intercept Call Completion Mass Announcement Services Person to Person calls Repeat Calls, Return Calls (per activation) Three Way Calling (per activation) Third Number Billed Time, Lottery and Weather
---	--

Issued by authority of an Order of the Public Service Commission of West Virginia in Case No. 11-0799-T-T dated June 21, 2011.

UNLIMITED LOCAL USAGE FOR BUSINESS

B. REGULATIONS (Cont'd)

9. Unlimited Local Usage for Business applies to voice traffic and may not be used for the transmission of data, for internet connections, or for any other non-voice application. This service may also not be used for autodialing. The Telephone Company reserves the right to restrict the amount of other services and equipment furnished or used in connection with any particular class of service in order to prevent any impairment in the quality of service furnished. If the Customer uses this Service for any non-eligible purpose, including, but not limited to, the examples noted above, the Telephone Company may suspend, restrict or cancel the Service. Details on calls made will not be available for this service.
10. Unlimited Local Usage for Business is available on a Month-to-Month basis or on a One-Year Term. Customers may discontinue the Month-to-Month package at any time upon request to the Telephone Company. In the event the customer terminates the One-Year Term service agreement within the first 60 days, starting on the Order Completion Date, the customer will be liable for the month-to-month charges up to the date of termination, and any termination liability will be waived. If the customer terminates service after 60-calendar days and prior to the completion of the term commitment period, the customer shall be liable for an early termination charge of 25% of the monthly recurring charge for the remainder of the term per line.
11. One-Year Term agreements are applied per line and are not required to be co-terminous. At the end of the term period or any subsequent renewal, the agreement will automatically be renewed for successive One-Year Terms unless either party provides advance notice that they do not wish to renew the term. Each subsequent renewal will allow for a 60 day grace period for the subscriber to remove the plan without penalty. If the customer after 60 calendar days and prior to the completion of the term commitment period terminates the agreement, the termination Liability Agreement (TLA) for an automatic renewal will be calculated by averaging the monthly service charges billed to the customer in the preceding four months. The TLA will not be greater than one month MRC. Pricing will remain the same during any automatic renewal unless Frontier has provided 30 days notice of any change

An early termination charge will not apply under the following circumstances:

- (a) Customer moves existing service either to a new customer location (C) within the same address and/or same building (inside move) or to a new customer location (outside move) and maintains that service for the remainder of the term; or (C)
- (b) Customer renegotiates a new term commitment plan for the same service before the current term commitment expires and the value of the new term commitment is equal to or greater than the remaining value of the current term commitment; or
- (c) Customer changes to another service or usage plan or upgrades service or usage under a term commitment, and the value of the new term commitment is equal to or greater than the remaining value of the current term commitment

Issued by authority of an Order of the Public Service Commission of West Virginia
Case No. _____ dated _____.

GENERAL SERVICES TARIFF
P.S.C.-W.Va.-No. 203

Frontier West Virginia Inc.

Section 32
2nd Revised Page 3
Cancels 1st Revised Page 3

UNLIMITED LOCAL USAGE FOR BUSINESS

C. APPLICATION OF RATES AND CHARGES

1. The Unlimited Local Usage for Business monthly rate applies in addition to and does not include a Basic Exchange Dial Tone Line or Communications System line. (C)
2. Service Connection charges will not apply to existing customers who choose to add Unlimited Local Usage for Business to their line(s).
3. Service charges will be waived in the event a class of service change is required in order to have Unlimited Local Usage for Business.

D. RATES

Unlimited Local Usage for Business

	<u>Monthly</u>	<u>1-Year Term</u>
Unlimited Local Usage		
Per Exchange Access Line*		
Per Communications System Access Line*		(C)

* Rates deregulated

Issued by authority of an Order of the Public Service Commission of West Virginia in Case No. 11-0799-T-T dated June 21, 2011.

Issued: June 2, 2011

Effective: July 2, 2011

GENERAL SERVICES TARIFF
P.S.C.-W.Va.-No. 203

Frontier West Virginia Inc.

Section 33
2nd Revised Page 1
Cancels 1st Revised Page 1

UNLIMITED LOCAL AND TOLL USAGE FOR BUSINESS

A. GENERAL

Unlimited Local and Toll Usage for Business is an optional calling plan which includes unlimited local and Toll voice usage for a flat monthly rate. Unlimited Local and Toll Usage for Business is only available to business customers with Business exchange service and/or Communications System Service, as set forth below. The Exchange Access line rate is not included. (C)

B. REGULATIONS

1. Unlimited Local and Toll Usage for Business is available on Business exchange service, and Communications System lines where facilities permit. (C)
2. Unlimited Local and Toll Usage for Business are available only to customers who subscribe to the Telephone Company as their carrier for all local and intraLATA toll calls.
3. Unlimited Local and Toll Usage for Business applies per telephone line.
4. Unlimited Local and Toll Usage for Business is available to business customers who, at the time of initiation of service, subscribe to 25 or fewer Telephone Company lines (voice grade or voice grade equivalent) per customer location.
5. Eligible business customers may subscribe to the Unlimited Local and Toll Usage for Business plan for up to ten (10) lines per customer location. A combination of Unlimited Local and Toll Usage for Business and Unlimited Local Usage for Business lines may not exceed a total of ten (10) lines per customer location.
6. Unlimited Local and Toll Usage for Business is not available with Flexible Digital Channel Service, Digital Service-Voice, LD and Internet, PBX trunks, ground start lines or trunks, ISDN Basic Service, ISDN Primary Service, Remote Call Forwarding Service, Foreign Exchange and Foreign Zone Service, Public Telephone Service and Foreign Central Office. (C)
7. Unlimited Local and Toll Usage for Business are not available with the following business packages or optional plans: Business Optional Calling Plan, Business Special Toll Plan, Company Rewards, Customer Specific Pricing Plans (CSP), Grandfathered Optional Discount Term Plan, and Virtual Private Network Service. (C)
8. Unlimited Local and Toll Usage for Business does not apply to the following calls and services: (C)

All Other Operator Handled Calls Busy Line Verification Busy Redial, *69, Call Trace (per activation) Collect Calls Calling Card Directory Assistance Directory Assistance Call Completion Emergency Interrupt 555, 700, 900, 976 Service (Audiotex)	Group Bridge Service Intercept Call Completion Mass Announcement Services Person to Person calls Repeat Calls, Return Calls (per activation) Three Way Calling (per activation) Third Number Billed Time, Lottery and Weather
---	--

Issued by authority of an Order of the Public Service Commission of West Virginia in Case No. 11-0799-T-T dated June 21, 2011.

UNLIMITED LOCAL AND TOLL USAGE FOR BUSINESS

B. REGULATIONS (Cont'd)

9. Unlimited Local and Toll Usage for Business applies to voice traffic and may not be used for the transmission of data, for internet connections, or for any other non-voice application. This service may also not be used for autodialing. The Telephone Company reserves the right to restrict the amount of other services and equipment furnished or used in connection with any particular class of service in order to prevent any impairment in the quality of service furnished. If the Customer uses this Service for any non-eligible purpose, including, but not limited to, the examples noted above, the Telephone Company may suspend, restrict or cancel the Service. Details on calls made will not be available for this service.
10. There will be no detailed toll billing on the Unlimited Local and Toll Usage for business package customer's bills.
11. Unlimited Local and Toll Usage Plan for Business is available with Month-to-Month or a One-Year Term. Customers may discontinue the month-to-month package at any time upon request to the Telephone Company. In the event the customer terminates the One-Year Term service agreement within the first 60 days, starting on the Order Completion Date, the customer will be liable for the month-to-month charges up to the date of termination, and any termination liability will be waived. If the customer terminates service after 60-calendar days and prior to the completion of the term commitment period, the customer shall be liable for an early termination charge of 25% of the monthly recurring charge for the remainder of the term per line.
12. One-Year Term agreements are applied per line and are not required to be co-terminous. At the end of the term period or any subsequent renewal, the agreement will automatically be renewed for successive One-Year Terms unless either party provides advance notice that they do not wish to renew the term. Each subsequent renewal will allow for a 60 day grace period for the subscriber to remove the plan without penalty. If the customer after 60 calendar days and prior to the completion of the term commitment period terminates the agreement, the termination Liability Agreement (TLA) for an automatic renewal will be calculated by averaging the monthly service charges billed to the customer in the preceding four months. The TLA will not be greater than one month MRC. Pricing will remain the same during any automatic renewal unless Frontier has provided 30 days notice of any change

An early termination charge will not apply under the following circumstances:

- (a) Customer moves existing service either to a new customer location within the same address and/or same building (inside move) or to a new customer location (outside move) and maintains that service for the remainder of the term; or (C)
- (b) Customer renegotiates a new term commitment plan for the same service before the current term commitment expires and the value of the new term commitment is equal to or greater than the remaining value of the current term commitment; or (C)
- (c) Customer changes to another service or usage plan or upgrades service or usage under a term commitment, and the value of the new term commitment is equal to or greater than the remaining value of the current term commitment.

Issued by authority of an Order of the Public Service Commission of West Virginia
Case No. _____ dated _____.

UNLIMITED LOCAL AND TOLL USAGE FOR BUSINESS

B. REGULATIONS (Cont'd)

(N)

13. The following optional feature packages are available to customers that subscribe to the Unlimited Local and Toll Usage for Business plan:

Feature Package 1 includes Call Forwarding, Call Waiting and Three-Way Calling. The customer can select any single feature, any combination of two features, or all three features in this package. All existing restrictions and regulations for the individual features will apply.

Feature Package 2 includes Call Forwarding, Caller ID or Call Waiting ID with Name. Subscription to Call Waiting is required for Call Waiting ID with Name. All existing restrictions and regulations for the individual features will apply.

Customers that subscribe to the Unlimited Local and Toll Usage for Business plan may order Feature Package 1 and Feature Package 2 subject to the availability of facilities. The monthly rates for the optional Feature Packages 1 and 2 are in addition to the monthly rates for the Unlimited Local and Toll Usage for Business plan. The optional feature packages must be on the same line as the Unlimited Local and Toll Usage for Business plan.

(N)

Issued by authority of an Order of the Public Service Commission of West Virginia
Case No. _____ dated _____.

GENERAL SERVICES TARIFF
P.S.C.-W.Va.-No. 203

Frontier West Virginia Inc.

Section 33
2nd Revised Page 4
Cancels 1st Revised Page 4

UNLIMITED LOCAL AND TOLL USAGE FOR BUSINESS

C. APPLICATION OF RATES AND CHARGES

1. The Unlimited Local and Toll Usage for Business monthly rate apply in addition to and do not include a Basic Exchange Dial Tone Line and/or CustoSak line.
2. Service and Equipment Charges do not apply to an existing customer who chooses to add Unlimited Local Usage for Business to their line.
3. Service charges will be waived in the event a class of service change is required in order to have Unlimited Local Usage for Business.

D. RATES

Unlimited Local and Toll Usage for Business

	<u>Monthly</u>	<u>1-Year Term</u>
Unlimited Local and Toll Usage		
Per Exchange Access Line*		
Per Communications System Access Line*		(C)
Feature Package 1*		
Feature Package 2*		

* Rates deregulated

Issued by authority of an Order of the Public Service Commission of West Virginia in Case No. 11-0799-T-T dated June 21, 2011.

GENERAL SERVICES TARIFF
P.S.C.-W.Va.-No. 203

Frontier West Virginia Inc.

Section 34
1st Revised Page 1
Cancels Original Page 1

UNLIMITED DIAL TONE LINE (DTL) AND UNLIMITED COMMUNICATIONS SYSTEM PACKAGES (C)

A. GENERAL

Unlimited DTL and Unlimited Communications System Basic Packages are optional (C) business flat-rated usage packages with a network access line, calling features and specified non-regulated services offered for a one-year or three-year term commitment. Customers must purchase at least one (1) Expansion Line for each Basic Package. Expansion Lines are offered on a monthly basis per each additional line ordered.

The following two (2) options are available:

1. Unlimited DTL Basic Package includes the following:

- One (1) Dial Tone Line with touch-tone
- Unlimited local calling
- Unlimited intraLATA toll calling
- Choice of one to five (1 - 5) of the following calling features:

Call Waiting, Three-Way Calling, Call Forwarding, Caller ID and a standard business voice messaging mailbox.

a. Unlimited DTL Expansion Lines

At least one (1) Expansion Line is required with each Unlimited DTL Basic Package. The following two (2) options are available:

(1) Expansion Lines with unlimited calling

DTL Expansion Lines are available for a monthly rate, per line, with unlimited local and intraLATA toll usage calling and a choice of one to five (1 to 5) of the following calling features:

Call Waiting, Three-Way Calling, Call Forwarding, Caller ID and a standard business voice messaging mailbox.

(2) Expansion Lines without unlimited calling

DTL Expansion Lines are available for a monthly rate, per line, and choice of one to five (1 to 5) of the following calling features:

Call Waiting, Three-Way Calling, Call Forwarding, Caller ID and a standard business voice messaging mailbox.

Issued by authority of an Order of the Public Service Commission of West Virginia in Case No. 11-0799-T-T dated June 21, 2011.

Issued: June 2, 2011

Effective: July 2, 2011

UNLIMITED DIAL TONE LINE (DTL) AND UNLIMITED COMMUNICATIONS SYSTEM PACKAGES (C)

A. GENERAL (Cont'd)

The following two (2) options are available: (Cont'd)

2. Unlimited Communications System Basic Package includes the following: (C)

- One (1) Communications System Line (C)
- Unlimited local calling
- Unlimited intraLATA toll calling
- Choice of one or both of the following calling features:

Caller ID and a standard business voice messaging mailbox.

a. Unlimited Communications System Expansion Lines (C)

At least one (1) Communications System Expansion Line is required (C)
with each Unlimited Communications System Basic Package. The (C)
following two (2) options are available:

(1) Expansion Lines with unlimited calling

Communications System Expansion Lines are available for a monthly (C)
rate, per line, with unlimited **local** and intraLATA toll usage calling
and a choice of one or both the following calling features:

Caller ID and a standard business voice messaging mailbox.

(2) Expansion Lines without unlimited calling

Communications System Expansion Lines are available for a monthly (C)
rate, per line, and choice of one or both of the following calling
features:

Caller ID and a standard business voice messaging mailbox.

GENERAL SERVICES TARIFF
P.S.C.-W.Va.-No. 203

Frontier West Virginia Inc.

Section 34
2nd Revised Page 3
Cancels 1st Revised Page 3

UNLIMITED DIAL TONE LINE (DTL) AND UNLIMITED COMMUNICATIONS SYSTEM PACKAGES (C)

B. REGULATIONS

1. Unlimited DTL and Communications System Basic Packages are available only where facilities and conditions permit. (C)
2. Unlimited DTL and Communications System Basic Packages are available only on a one-year or three-year term agreement. Expansion Lines are available on a month-to-month basis only. (C)
3. Unlimited DTL and Communications System Basic Packages are only available with subscription to a business unlimited nationwide long distance calling plan through New Communications Online and Long Distance and Frontier highspeed internet service. Each Expansion Line must also subscribe to a business long distance calling plan through New Communications Online and Long Distance. (C)
4. Unlimited DTL and Communications System Basic Packages are available to business customers who subscribe to 25 or fewer lines (voice grade or voice grade equivalent) per customer location at the time service is initiated. (C)
5. At each customer location, customers must purchase at least one (1) Expansion Line with each Unlimited DTL Basic Package or Unlimited Communications System Basic Package. Customers are allowed up to 24 Expansion Lines per customer location. A maximum of nine such lines per customer location can have Unlimited Calling either with this plan or any other unlimited local and/or toll product offered by Frontier. (C)
6. Customers may have any combination of Expansion Lines but the combined total number of Expansion Lines allowed is 24 per customer location and may not exceed nine (9) Expansion Lines with Unlimited Calling per customer location. (C)
7. Unlimited DTL and Communications System Basic Packages are not available with the following services: (C)
 - Flexible Digital Channel Service or Digital Service-Voice, LD and Internet (C)
 - ISDN Service
 - Remote Call Forwarding Service
 - Auto Universal Call Distribution (ACD/UCD)
 - PBX Trunks
 - Digital Hand Off
 - Digital PBX Service
 - Foreign Exchange Service
 - Foreign Central Office Service
 - Ground Start Lines or Trunks
 - Business Optional Calling Plan
 - Business Special Toll Plan
 - Company Rewards (C)
 - Business Local Usage Packages with allowances for Centrex and Business service
 - Customer Specific Pricing (CSP)
 - Grandfathered Optional Discount Term Plan (C)
 - Long Distance Calling Plan-Two Point Service (C)
 - Service for Payphones
 - Foreign Zone Service

Issued by authority of an Order of the Public Service Commission of West Virginia in Case No. 11-0799-T-T dated June 21, 2011.

Issued: June 2, 2011

Effective: July 2, 2011

GENERAL SERVICES TARIFF
P.S.C.-W.Va.-No. 203

Frontier West Virginia Inc.

Section 34
1st Revised Page 4
Cancels Original Page 4

UNLIMITED DIAL TONE LINE (DTL) AND UNLIMITED COMMUNICATIONS SYSTEM PACKAGES (C)

B. REGULATIONS (Cont'd)

8. Unlimited DTL and Communications System Basic Packages are not available (C)
in combination with other optional calling plans or virtual private network services.
9. Unlimited DTL and Communications System Basic Packages do not apply to the (C)
following calls or services:
 - Collect Calls
 - Calling Card
 - Time, Lottery and Weather
 - 555,700, 900, 976 Service
 - IDS Type Calls (Audiotext)
 - Third Number Billed
 - Intercept Call Completion
 - Mass Announcement Services
 - Directory Assistance
 - Group Bridging Service
 - Service Request Calls/Directory Assistance Call Completion (C)
 - Business Basic Plan Service
 - Emergency Interrupt
 - Repeat Calls, Return Calls (per activation)
 - Person-to-Person
 - Busy Line Verification
 - All other operator Handled Calls
 - Three-Way calling (per activation)
 - Busy Redial, *69, Call trace (per activation)
 - Directory Assistance Call Completion
10. Unlimited DTL and Communications System Basic Packages may only be used for (C)
voice applications and may not be used for the transmission of data, for internet connections, or for any other non-voice application. These services may not be used for autodialing. The Company reserves the right to restrict the number of other services and/or equipment furnished or used in connection with any particular class of service in order to prevent any impairment in the quality of service furnished. If the customer uses this service for any non-eligible purpose, including, but not limited to, the examples noted above, the Company may suspend, restrict or cancel the service.
11. Details on calls made will not be available for this service.
12. Service Connection Charges will be waived in the event a class of service (C)
change is required in order to have an Unlimited DTL or Communications (C)
System Basic Packages.
13. Applicable Service Charges as specified in the General Services Tariff, No. 203, Sec. 3, will be waived for customers subscribing to a three-year agreement.

Issued by authority of an Order of the Public Service Commission of West Virginia
in Case No. 11-0799-T-T dated June 21, 2011.

Issued: June 2, 2011

Effective: July 2, 2011

GENERAL SERVICES TARIFF
P.S.C.-W.Va.-No. 203

Frontier West Virginia Inc.

Section 34
1st Revised Page 5
Cancels Original Page 5

UNLIMITED DIAL TONE LINE (DTL) AND UNLIMITED COMMUNICATIONS SYSTEM PACKAGES (C)

C. TERMINATION LIABILITY

Unlimited DTL and Unlimited Communications System Basic Packages are offered (C)
on a one-year or a three-year term agreement.

Early termination of an Unlimited DTL Basic Package or Unlimited (C)
Communications System Package term agreement by the customer will result in a
one-time flat Termination Charge of:

1-year term agreement

\$75

3-year term agreement

\$225 for default within the 1st year of the term

\$150 for default within the 2nd year of the term

\$75 for default within the 3rd year of the term

If the customer cancels any of the unregulated components or all of the
Expansion Line(s) of the bundle, the remaining components will revert to the
individual rate and/or the tariff rate associated with that component.

The customer can add, delete or change the Expansion Lines without termination
charges as long as two (2) lines (the core, Basic Package, and one Expansion
Line) remain on the account. If the one Expansion Line is removed, the
remaining elements will revert to tariff rates. If the Basic Package core
line is removed, the applicable termination charge shown above will apply.

Customer termination of service within the first 60 days, starting on the
Order Completion Date, will result in customer liability for the monthly
charges. Termination liability will be waived.

At the end of the term period or any subsequent renewal, the agreement will
automatically be renewed for a successive one-year or three-year term at the
same terms and conditions, unless either party provides advance notice that it
does not wish to renew the term. Each subsequent renewal will allow for a 60-
day grace period for the subscriber to unsubscribe from the plan without
penalty. Pricing will remain the same during any automatic renewal unless the
Company has provided 30 days notice of any change. Customers can move from a
one-year to a three-year term without incurring a penalty.

If the customer after 60 calendar days and prior to the completion of the term
commitment period terminates the agreement, the Termination Liability
Agreement (TLA) for an automatic renewal will be calculated by averaging the
monthly service charges billed to the customer in the preceding four months.
The TLA will not be greater than one month MRC.

Issued by authority of an Order of the Public Service Commission of West Virginia
in Case No. 11-0799-T-T dated June 21, 2011.

GENERAL SERVICES TARIFF
P.S.C.-W.Va.-No. 203

Frontier West Virginia Inc.

Section 34
2nd Revised Page 6
Cancels 1st Revised Page 6

UNLIMITED DIAL TONE LINE (DTL) AND UNLIMITED COMMUNICATIONS SYSTEM PACKAGES (C)

C. TERMINATION LIABILITY (cont'd)

An early termination charge will not apply under the following circumstances:

- (1) Customer moves existing service either to a new customer location within the same address and/or same building (inside move) or to a new customer location (outside move) and maintains that service for the remainder of the term;
- (2) Customer renegotiates a new term commitment plan for the same service before the current term commitment expires and the value of the new term commitment is equal to or greater than the remaining value of the current term commitment; or
- (3) Customer changes to another service or usage plan or upgrades service or usage under a term commitment, and the value of the new term commitment is equal to or greater than the remaining value of the current term commitment.

Issued by authority of an Order of the Public Service Commission of West Virginia in Case No. 11-0799-T-T dated June 21, 2011.

Issued: June 2, 2011

Effective: July 2, 2011

GENERAL SERVICES TARIFF
P.S.C.-W.Va.-No. 203

Frontier West Virginia Inc.

Section 34
2nd Revised Page 7
Cancels 1st Revised Page 7

UNLIMITED DIAL TONE LINE (DTL) AND UNLIMITED COMMUNICATIONS SYSTEM PACKAGES (C)

D. RATES AND CHARGES

	<u>Monthly Rate</u>	
	<u>1-Year Term</u>	<u>3-Year Term</u>
1. <u>Unlimited DTL Basic Packages</u> ¹	*	*
	<u>Monthly Rate</u>	
Expansion Line with Unlimited Calling, per line ²		*
Expansion Line without Unlimited Calling, per line ^{2,3}		*
	<u>Monthly Rate</u>	
	<u>1-Year Term</u>	<u>3-Year Term</u>
2. <u>Unlimited Communications System Basic Packages</u> ¹	*	*
	<u>Monthly Rate</u>	
Expansion Line with Unlimited Calling, per line ²		*
Expansion Line without Unlimited Calling, per line ^{2,3}		*

* Rates deregulated.

¹ At least one (1) Expansion Line is required with each Unlimited DTL Basic Package or Unlimited Communications System Basic Package ordered per customer location. (C)

² Customers may have any combination of Expansion Lines but the combined total number allowed is 24 per customer location and may not exceed nine (9) Expansion Lines with Unlimited Calling per customer location.

³ Usage rates apply in addition to the monthly rate.

Issued by authority of an Order of the Public Service Commission of West Virginia in Case No. 11-0799-T-T dated June 21, 2011.

Issued: June 2, 2011

Effective: July 2, 2011

GENERAL SERVICES TARIFF
P.S.C.-W.Va.-No. 203

Frontier West Virginia Inc.

Section 35
1st Revised Page 1
Cancels Original Page 1

SINGLE LINE BUSINESS PAK

A. GENERAL

Single Line Business Pak is an optional business flat-rated usage package with a network access line, calling features and specified non-regulated services offered for a one-year or three-year term commitment.

Single Line Business Pak includes the following:

- One (1) Dial Tone Line with touch-tone
- Unlimited local voice usage
- Unlimited intraLATA direct distance dialed unassisted toll calling
- Choice of zero to five (0 - 5) of the following calling features:
Call Waiting, Three-Way Calling, Call Forwarding, Caller ID and standard business Voice Messaging Mailbox (a non-regulated service).

NOTE: Additional credit will apply if provisioned with Frontier Broadband Service. (C)

B. REGULATIONS

1. Single Line Business Pak is available only where facilities and conditions permit.
2. Single Line Business Pak is available only to customers who subscribe to Frontier for their local usage and intraLATA toll calls.
3. Single Line Business Pak is available only on a one-year or three-year term agreement.
4. Single Line Business Pak is only available to business customers who agree to subscribe to a business unlimited nationwide long distance calling plan through New Communications Online and Long Distance Tariffs No. 1 or No. 2 and Frontier Broadband service. (C)
(C)
5. Single Line Business Pak is available to business customers who subscribe to 25 or fewer lines (voice grade or voice grade equivalent) at the time service is initiated.
6. Customers may only have one Single Line Business Pak per account. A maximum of ten lines may have Unlimited Calling either with this plan or any other Unlimited Local or Unlimited Local and Toll Usage product offered by Verizon. Customers may not combine this package with the Unlimited Dialtone Line and Unlimited Communications System Packages. (C)

Issued by authority of an Order of the Public Service Commission of West Virginia in Case No. 11-0799-T-T dated June 21, 2011.

Issued: June 2, 2011

Effective: July 2, 2011

GENERAL SERVICES TARIFF
P.S.C.-W.Va.-No. 203

Frontier West Virginia Inc.

Section 35
1st Revised Page 2
Cancels Original Page 2

SINGLE LINE BUSINESS PAK

B. REGULATIONS (Cont'd)

7. Single Line Business Pak is not available with the following services:

- Centrex or Communications System (C)
- Flexible Digital Channel service or Digital Service-Voice, LD (C)
and Internet (C)
- ISDN Service
- Remote Call Forwarding Service
- Auto Universal Call Distribution (ACD/UCD)
- PBX Trunks
- Digital Hand Off
- Digital PBX Service
- Foreign Exchange Service
- Foreign Central Office Service
- Ground Start Lines or Trunks
- Business Optional Calling Plan
- Long Distance Calling Plan-Two Point Service (C)
- Company Rewards (C)
- VPNS
- Customer Specific Pricing (CSP)
- Grandfathered Optional Discount Term Plan (C)
- Foreign Zone Service
- Service for Payphone Telephone Lines
- Unlimited Dialtone Line and Unlimited Communications System Packages (C)

8. Single Line Business Pak is not available in combination with other optional calling plans or virtual private network services.

9. Single Line Business Pak does not apply to the following calls or services:

- Collect Calls
- Calling Card
- Time, Lottery and Weather
- 555,700, 900, 976 Service
- Third Number Billed
- Intercept Call Completion

Issued by authority of an Order of the Public Service Commission of West Virginia in Case No. 11-0799-T-T dated June 21, 2011.

Issued: June 2, 2011

Effective: July 2, 2011

GENERAL SERVICES TARIFF
P.S.C.-W.Va.-No. 203

Frontier West Virginia Inc.

Section 35
1st Revised Page 3
Cancels Original Page 3

SINGLE LINE BUSINESS PAK

B. REGULATIONS (Cont'd)

9. Single Line Business Pak does not apply to the following calls or services:
(Cont'd)
- Mass Announcement Services
 - Directory Assistance
 - Service Request Calls/Directory Assistance Call Completion (C)
 - Business Basic Plan Service (C)
 - Emergency Interrupt
 - Repeat Calls, Return Calls (per activation)
 - Person-to-Person
 - Busy Line Verification
 - All other operator Handled Calls
 - Three-Way calling (per activation)
 - Busy Redial, *69, Call trace (per activation)
10. Single Line Business Pak may only be used for voice applications and may not be used for the transmission of data, for internet connections, or for any other non-voice application. These services may not be used for autodialing. The Company reserves the right to restrict the number of other services and/or equipment furnished or used in connection with any particular class of service in order to prevent any impairment in the quality of service furnished. If the customer uses this service for any non-eligible purpose, including, but not limited to, the examples noted above, the Company may suspend, restrict or cancel the service.
11. Details on calls made will not be available for this service.
12. Service Connection Charges will be waived in the event a class of service change is required in order to have the Single Line Business Pak.
13. Applicable Service Charges as specified in the General Services Tariff No. 203, Section 3, will be waived for customers subscribing to a three-year agreement.

Issued by authority of an Order of the Public Service Commission of West Virginia
in Case No. 11-0799-T-T dated June 21, 2011.

Issued: June 2, 2011

Effective: July 2, 2011

SINGLE LINE BUSINESS PAK

C. TERMINATION LIABILITY

1. Single Line Business Pak is offered on a one-year or a three-year term agreement.
2. Early termination of Single Line Business Pak term agreement by the customer will result in a one-time flat Termination Charge of:

1-year term agreement:

\$75

3-year term agreement

\$125 for default within the 1st year of the term
\$100 for default within the 2nd year of the term
\$75 for default within the 3rd year of the term

3. If the customer cancels any of the components: the business unlimited nationwide long distance calling plan through New Communications Online (C) and Long Distance Tariffs No. 1 or No. 2 or the Frontier Broadband Service, (C) the remaining components will revert to the individual rate and/or the tariff rate associated with that component.
4. If the Dialtone Line (DTL) is removed, the applicable termination charge shown above will apply.
5. Customer termination of service within the first 60 days, starting on the Order Completion Date, will result in customer liability for the monthly charges. Termination liability will be waived.
6. At the end of the term period or any subsequent renewal, the agreement will automatically be renewed for a successive one-year or three-year term at the same terms and conditions, unless either party provides advance notice that it does not wish to renew the term. Each subsequent renewal will allow for a 60-day grace period for the subscriber to unsubscribe from the plan without penalty. Pricing will remain the same during any automatic renewal unless the Company has provided 30 days notice of any change. Customers can move from a one-year to a three-year term without incurring a penalty.

If the Customer after 60 calendar days and prior to the completion of the term commitment period terminates the agreement, the Termination Liability Agreement (TLA) for an automatic renewal will be calculated by averaging the monthly service charges billed to the customer in the preceding four months. The TLA will not be greater than one month MRC.

GENERAL SERVICES TARIFF
P.S.C.-W.Va.-No. 203

Frontier West Virginia Inc.

Section 35
Original Page 5

SINGLE LINE BUSINESS PAK

C. TERMINATION LIABILITY (Cont'd)

7. An early termination charge will not apply under the following circumstances:

- (a) Customer moves existing service either to a new location within the same address and/or same building (inside move) or to a new location (outside move) and maintains that service for the remainder of the term;
- (b) Customer renegotiates a new term commitment plan for the same service before the current term commitment expires and the value of the new term commitment is equal to or greater than the remaining value of the current term commitment; or
- (c) Customer changes to another service or usage plan or upgrades service or usage under a term commitment, and the value of the new term commitment is equal to or greater than the remaining value of the current term commitment.

(N)

(N)

Issued by authority of an Order of the Public Service Commission of West Virginia
Case No. _____ dated _____.

Issued: May 29, 2009

Effective: June 29, 2009

GENERAL SERVICES TARIFF
P.S.C.-W.Va.-No. 203

Frontier West Virginia Inc.

Section 35
1st Revised Page 6
Cancels Original Page 6

SINGLE LINE BUSINESS PAK

D. RATES

	<u>Monthly Rate</u>	
	<u>3-Year Term</u>	<u>1-Year Term</u>
1. Single Line Business Pak	*	*

	<u>Monthly Discount</u>	
	<u>3-Year Term</u>	<u>1-Year Term</u>
2. Frontier Affiliate Broadband Bundle Discount	*	*

(C)

* Rates Deregulated

Issued by authority of an Order of the Public Service Commission of West Virginia
in Case No. 11-0799-T-T dated June 21, 2011.

Issued: June 2, 2011

Effective: July 2, 2011

GENERAL SERVICES TARIFF
P.S.C.-W.Va.-No. 203

Frontier West Virginia Inc.

Section 36
1st Revised Page 1
Cancels Original Page 1

SOLUTIONS FOR BUSINESS BUNDLE

A. GENERAL

1. Solutions for Business Bundle is an optional business package that includes a network access line (or Communications System), calling features and a specified non-regulated service offered for a one-year or three-year term commitment as well as three additional line types that are offered on a month-to-month basis. (C)
2. Solutions for Business Bundle Main Line includes the following:
 - One Network Access Line (or Communications System) with touch calling (C)
 - Unlimited Local and IntraLATA Toll calling
 - Choice of zero to five (0 - 5) of the following calling features:
 - Call Waiting
 - Three-Way Calling
 - Call Forwarding
 - Caller ID
 - a specified non-regulated service
3. Solutions for Business Bundle Additional Line includes the following:
 - Additional Bundle Line
 - One Communications System line (C)
 - Additional Bundle Line-Plus
 - One Communications System line (C)
 - Caller ID and a specified non-regulated service
 - Additional Bundle Line-Unlimited
 - One Communications System line (C)
 - Caller ID and Caller ID and a specified non-regulated service
 - Unlimited Local and IntraLATA Toll calling

Issued by authority of an Order of the Public Service Commission of West Virginia in Case No. 11-0799-T-T dated June 21, 2011.

Issued: June 2, 2011

Effective: July 2, 2011

GENERAL SERVICES TARIFF
P.S.C.-W.Va.-No. 203

Frontier West Virginia Inc.

Section 36
1st Revised Page 2
Cancels Original Page 2

SOLUTIONS FOR BUSINESS BUNDLE

B. REGULATIONS

1. Solutions for Business Bundle is available only where facilities and conditions permit. Solutions for Business Bundle is available only to customers who subscribe to the Company for their Local Usage and IntraLATA Toll calls.
2. Solutions for Business Bundle is available only on a one-year or three-year term agreement.
3. Solutions for Business Bundle is only available with subscription to a business unlimited nationwide long distance calling plan through New Communications Online and Long Distance and Frontier High-Speed Internet service. (C) (C)
4. Solutions for Business Bundle is available to business customers who subscribe to 25 or fewer lines (voice grade or voice grade equivalent) at the time service is initiated.
5. Customers may have only one Solution for Business Bundle per account. A maximum of ten (10) lines can have unlimited calling. Customers may not combine this package with the Unlimited Dial Tone Line (DTL) Package for Business, the Unlimited Communications System Package for Business, the Single Line Business PAK for Business, Unlimited Local Usage for Business, or Unlimited Local and Toll Usage for Business. (C)
6. Solutions for Business Bundle is not available with the following services:
 - Flexible Digital Channel Service or Digital Service-Voice, LD and Internet (C) (C)
 - ISDN Service Single Line Service
 - ISDN Basic Rate Service
 - ISDN Primary Rate Service
 - Ground Start Lines or Trunks
 - Remote Call Forwarding Service
 - Foreign Exchange Service
 - Foreign Central Office Service
 - Foreign Zone Service
 - Coin or Pay Telephone Service
7. Solutions for Business Bundle is not available in combination with other optional calling plans or virtual private network services.

Issued by authority of an Order of the Public Service Commission of West Virginia in Case No. 11-0799-T-T dated June 21, 2011.

Issued: June 2, 2011

Effective: July 2, 2011

SOLUTIONS FOR BUSINESS BUNDLE

(N)

B. REGULATIONS (Cont'd)

8. Solutions for Business Bundle does not apply to the following calls or services:

- Collect Calls
- Calling Card
- Time and Weather
- 555,700, 900, 976 Service
- Third Number Billed
- Directory Assistance - Call Completion
- Directory Assistance
- Group Bridging Service
- Emergency Interrupt
- Repeat Calls, Return Calls (per activation)
- Person-to-Person
- Busy Line Verification
- Intercept Call Completion
- All other operator Handled Calls
- Three-Way Calling (per activation)

9. Lines with unlimited calling are for voice applications and may not be used for the transmission of data, for internet connections, or for any other non-voice application. These services may not be used for autodialing. The Company reserves the right to restrict the number of other services and/or equipment furnished or used in connection with any particular class of service in order to prevent any impairment in the quality of service furnished. If the customer uses this service for any non-eligible purpose, including, but not limited to, the examples noted above, the Company may suspend, restrict or cancel the service.

10. Details on calls made will not be available for this service.

11. Service Connection Charges will be waived in the event a class of service change is required in order to have Solutions for Business Bundle.

12. Applicable Service Charges will be waived for customers subscribing to a three-year agreement.

(N)

SOLUTIONS FOR BUSINESS BUNDLE

(N)

C. TERMINATION LIABILITY

1. Solutions for Business Bundle is offered on a one-year or a three-year term agreement.
2. Early termination of a Solution for Business Bundle term agreement by the customer during any month of the 1 or 3 year term will result in a one-time flat Termination Charge of \$50.00.
3. Customer termination of service within the first 30 days, starting on the Order Completion Date, will result in customer liability for the monthly charges. Termination liability will be waived.
4. At the end of the term period the customer will revert to a monthly term at their current rate. Customers not under a term will be subject to price changes. Therefore, customers must contact Frontier to enter into another term contract.
5. An early termination charge will not apply under the following circumstances:
 - Customer moves existing service either to a new location within the same address and/or same building (inside move) or to a new location (outside move) and maintains that service for the remainder of the term;
 - Customer renegotiates a new term commitment plan for the same service before the current term commitment expires and the value of the new term commitment is equal to or greater than the remaining value of the current term commitment; or
 - Customer changes to another service or usage plan or upgrades service or usage under a term commitment, and the value of the new term commitment is equal to or greater than the remaining value of the current term commitment.
 - At the end of the term period, the customers will revert to monthly changes on a month-to-month basis at their current rate, unless the customer re-subscribes to another term commitment. Customers not under a term commitment will be subject to rate change.
 - Solutions for Business Bundle Additional Lines will be offered on a month-to-month basis and the customer can add and delete the additional lines without termination charges as long as the main line remains on the account.

(N)

GENERAL SERVICES TARIFF
P.S.C.-W.Va.-No. 203

Frontier West Virginia Inc.

Section 36
1st Revised Page 5
Cancels Original Page 5

SOLUTIONS FOR BUSINESS BUNDLE

D. RATES

	<u>Monthly Rate</u>		
	<u>1-Year Term</u>	<u>3-Year Term</u>	
1. Solutions for Business Bundle Main Line	*	*	
		<u>Monthly Credit</u>	
		<u>1-Year Term</u> <u>3-Year Term</u>	
2. Frontier Broadband Credit	*	*	(C)
		<u>Monthly Rate</u>	
3. Solutions for Business Bundle Additional Line			
Additional Bundle Line		*	
Additional Bundle Line-Plus		\$*	
Additional Bundle Line-Unlimited		*	
		<u>Monthly Credit</u>	
4. Frontier Broadband Credit (applies to Additional Bundle Line-Unlimited only)		*	(C)

* Rates deregulated.

Issued by authority of an Order of the Public Service Commission of West Virginia in Case No. 11-0799-T-T dated June 21, 2011.

Issued: June 2, 2011

Effective: July 2, 2011

FRONTIER BUSINESS UNLIMITED SERVICE

(N)

A. GENERAL

1. Frontier Business Unlimited Service is a bundled offering available to Business customers that subscribe to a maximum of ten Single Party Business Lines per customer location. The package includes a flat rate Basic Business Line (Plan 2), a combination of enhanced calling features, certain designated non-regulated services and price-listed services.

Basic Bundle

One-Party Flat Rate Business Access Line (Plan 2)
Call Forwarding (associated with Voice Mail)
Caller ID Name and Number
Frontier Business Deluxe Voice Mail (non-regulated)
Two features from the Frontier Business All In Feature Package listed below

Frontier Business All In Feature Package

*69
Busy Redial
Call Forwarding Busy/No Answer-Fixed
Call Forwarding Busy Line-Fixed
Call Forwarding No Answer-Fixed
Call Waiting/Cancel Call Waiting
Distinctive Ring
Selective Call Rejection
Speed Dialing 8
Speed Dialing 30
Three Way Calling
VIP Alert

All of these features can be added to the bundle for the rate specified in C.

B. REGULATIONS

1. The bundle is available only where facilities and operating systems are available and technically feasible.
2. The features are provided subject to their individual service regulations as specified in the applicable schedules of the tariff.

(N)

FRONTIER BUSINESS UNLIMITED SERVICE

(N)

B. REGULATIONS (Cont'd)

3. Frontier Business Unlimited Service includes basic local service and non-basic local services. Non-payment or partial payment of the bill may result in the cancellation of the bundled package and all services will be charged their individual tariffed rate. Payment will then be applied in accordance with existing Commission Rules and Regulations for the Government of Telephone Utilities.
4. Customers may add or delete any features offered within the bundle without incurring a Service Connection Charge.
5. If the customer disconnects any component of the bundle, the remaining components of the bundle will be billed at their individual tariffed monthly rates.
6. The bundle is available only to customers who are served from a central office in which services in the bundle are offered and can be provided by the Company to the customer.
7. The bundle cannot be used in association with a Residential Line, PBX Service, ISDN Service, Toll Free Service, Remote Call Forwarding Service and Foreign Exchange Services.
8. The bundle is offered only under a month-to-month commitment.

C. RATES

1. All Interstate End User Subscriber Line charges and other applicable surcharges and taxes will be billed separately from and are in addition to the bundle rate.
2. Unless otherwise stated elsewhere in this section, Connection Charges apply to the installation of individual components of the bundle.
3. Frontier Business Unlimited Service is provided at the following rates:

	<u>Monthly Rate</u>
Frontier Business Unlimited - Basic Bundle	*
Frontier Business All In Feature Package	*

* Rates deregulated.

(N)

Issued by authority of an Order of the Public Service Commission of West Virginia in Case No. 10-1860-T-T dated December 20, 2010.

FRONTIER BUSINESS ESSENTIALS

(N)

A. GENERAL

1. Frontier Business Essentials is a package offering available to Business Customers. The package includes a flat rate Basic Business Line (Plan 2), a combination of enhanced calling features, certain designated non-regulated services and price-listed services.

Basic Bundle

Flat Rate Business Line (Plan 2)
Call Forwarding (associated with Voice Mail)
Basic Voice Mail (non-regulated)
Two features from the Frontier Business All In Feature Package listed below

Frontier Business All In Feature Package

*69
Busy Redial
Caller ID Name and Number
Call Forwarding Busy/No Answer-Fixed
Call Forwarding Busy Line-Fixed
Call Forwarding No Answer-Fixed
Call Waiting/Cancel Call Waiting
Distinctive Ring
Selective Call Rejection
Speed Dialing 8
Speed Dialing 30
Three Way Calling
VIP Alert
Frontier Business Deluxe Voice Mail (non-regulated)

All of these features can be added to the bundle for the rate specified in C.

(N)

GENERAL SERVICES TARIFF
P.S.C.-W.Va.-No. 203

Frontier West Virginia Inc.

Section 38
Original Page 2

FRONTIER BUSINESS ESSENTIALS

(N)

B. REGULATIONS

1. A bundle is available only to customers who are served from a central office in which all services in the bundle are offered and can be provided by the Company to the customer.
2. The bundles are offered on a month to month basis.
3. All applicable surcharges and taxes will be billed separately from and in addition to the bundle rate.
4. The bundle cannot be used in association with a Residential Line, PBX Service or ISDN service.

C. RATES

	<u>Monthly Rate</u>
Frontier Business Essentials - Basic Bundle	*
Frontier Business All In Feature Package	*

* Rates deregulated.

(N)

Issued by authority of an Order of the Public Service Commission of West Virginia in Case No. 10-1860-T-T dated December 20, 2010.

Issued: December 8, 2010

Effective: December 22, 2010

GENERAL SERVICES TARIFF
P.S.C.-W.Va.-No. 203

Frontier West Virginia Inc.

Section 39
1st Revised Page 1
Cancels Original Page 1

FRONTIER BUSINESS NATIONWIDE UNLIMITED SERVICE II ¹

(C)

A. GENERAL

1. Frontier Business Nationwide Unlimited Service II is a bundled offering available to Business customers that subscribe to a maximum of twelve Single Party Business Lines per customer location. The package includes a flat rate Basic Business Line (Plan 2), a combination of enhanced calling features, certain designated non-regulated services and price-listed services.

Basic Bundle

One-Party Flat Rate Business Access Line (Plan 2)
Call Forwarding (associated with Voice Mail)
Caller ID Name and Number
Frontier Business Deluxe Voice Mail (non-regulated)
Six features from the Frontier Business All In Feature Package listed below

Frontier Business All In Feature Package

*69
Busy Redial
Call Forwarding Busy/No Answer-Fixed
Call Forwarding Busy Line-Fixed
Call Forwarding No Answer-Fixed
Call Waiting/Cancel Call Waiting
Distinctive Ring
Selective Call Rejection
Speed Dialing 8
Speed Dialing 30
Three Way Calling
VIP Alert

All of these features can be added to the bundle for the rate specified in C.

B. REGULATIONS

1. The bundle is available only where facilities and operating systems are available and technically feasible.
2. The features are provided subject to their individual service regulations as specified in the applicable schedules of the tariff.

¹ Effective January 20, 2018 this service offering is limited to existing subscribers.

(N)
(N)

Issued by authority of an Order of the Public Service Commission of West Virginia in Case No. 18-0013-T-T dated January 19, 2018.

GENERAL SERVICES TARIFF
P.S.C.-W.Va.-No. 203

Frontier West Virginia Inc.

Section 39
1st Revised Page 2
Cancels Original Page 2

FRONTIER BUSINESS NATIONWIDE UNLIMITED SERVICE II ¹

(C)

B. REGULATIONS (Cont'd)

3. Frontier Business Nationwide Unlimited Service II includes basic local service and non-basic local services. Non-payment or partial payment of the bill may result in the cancellation of the bundled package and all services will be charged their individual tariffed rate. Payment will then be applied in accordance with existing Commission Rules and Regulations for the Government of Telephone Utilities.
4. Customers may add or delete any features offered within the bundle without incurring a Service Connection Charge.
5. The bundle cannot be used in association with a Residential Line, PBX Service, ISDN Service, Toll Free Service, Remote Call Forwarding Service and Foreign Exchange Services.
6. The bundle is offered on a month to month basis.
7. Up to eleven additional bundles can be purchased at the rate specified in C.

C. RATES

1. All Interstate End User Subscriber Line charges and other applicable surcharges and taxes will be billed separately from and are in addition to the bundle rate.
2. Unless otherwise stated elsewhere in this section, Connection Charges apply to the installation of individual components of the bundle.
3. Frontier Business Nationwide Unlimited Service II is provided at the following rates:

	<u>Monthly Rate</u>
Frontier Business Nationwide Unlimited Service II - Initial Line - Basic Bundle	*
Frontier Business Nationwide Unlimited Service II - Additional Line - Basic Bundle	*
Frontier Business All In Feature Package	*

* Rates deregulated.

¹ Effective January 20, 2018 this service offering is limited to existing subscribers.

(N)
(N)

Issued by authority of an Order of the Public Service Commission of West Virginia in Case No. 18-0013-T-T dated January 19, 2018.

Issued: January 5, 2018

Effective: January 20, 2018

GENERAL SERVICES TARIFF
P.S.C.-W.Va.-No. 203

Frontier West Virginia Inc.

Section 40
1st Revised Page 1
Cancels Original Page 1

FRONTIER BUSINESS LOCAL UNLIMITED II ¹

(C)

A. GENERAL

1. Frontier Business Local Unlimited II is a package offering available to Business Customers. The package includes a flat rate Basic Business Line (Plan 2), a combination of enhanced calling features, certain designated non-regulated services and price-listed services.

Basic Bundle

Flat Rate Business Line (Plan 2)

Two features from the Frontier Business All In Feature Package listed below

Frontier Business All In Feature Package

*69

Busy Redial

Caller ID Name and Number

Call Forwarding Busy/No Answer-Fixed

Call Forwarding Busy Line-Fixed

Call Forwarding No Answer-Fixed

Call Waiting/Cancel Call Waiting

Distinctive Ring

Selective Call Rejection

Speed Dialing 8

Speed Dialing 30

Three Way Calling

VIP Alert

Frontier Business Basic or Deluxe Voice Mail (non-regulated)

All of these features can be added to the bundle for the rate specified in C.

¹ Effective January 20, 2018 this service offering is limited to existing subscribers.

(N)
(N)

Issued by authority of an Order of the Public Service Commission of West Virginia in Case No. 18-0013-T-T dated January 19, 2018.

Issued: January 5, 2018

Effective: January 20, 2018

GENERAL SERVICES TARIFF
P.S.C.-W.Va.-No. 203

Frontier West Virginia Inc.

Section 40
1st Revised Page 2
Cancels Original Page 2

FRONTIER BUSINESS LOCAL UNLIMITED II ¹

(C)

B. REGULATIONS

1. A bundle is available only to customers who are served from a central office in which services in the bundle are offered and can be provided by the Company to the customer.
2. The bundles are offered on a month to month basis.
3. All applicable surcharges and taxes will be billed separately from and in addition to the bundle rate.
4. The bundle cannot be used in association with a Residential Line, PBX Service or ISDN service.
5. Customers may select any two of the features in the Frontier Business All In Feature Package for no extra charge.
6. Customers purchasing the Frontier Business All In Feature Package may select any or all of the features listed in that package.

C. RATES

	<u>Monthly Rate</u>
Frontier Business Local Unlimited II - Basic Bundle	*
Frontier Business All In Feature Package	*

* Rates deregulated.

¹ Effective January 20, 2018 this service offering is limited to existing subscribers.

(N)
(N)

Issued by authority of an Order of the Public Service Commission of West Virginia in Case No. 18-0013-T-T dated January 19, 2018.

Issued: January 5, 2018

Effective: January 20, 2018

GENERAL SERVICES TARIFF
P.S.C.-W.Va.-No. 203

Frontier West Virginia Inc.

Section 41
Original Page 1

INTEGRATED SERVICES DIGITAL NETWORK PRIMARY RATE INTERFACE BUNDLE SERVICE

(N)

A. GENERAL

1. Integrated Services Digital Network (ISDN) Primary Rate Interface (PRI) Bundle Service is a bundled offering available to business customers that provides a digital trunk with 23 B-channels for circuit switched voice and data and 1 D-channel for signaling (Dedicated PRI) plus Caller ID Name and Number and the option of Direct Inward Dialing (DID) numbers.

B. REGULATIONS

1. ISDN PRI Bundle Service is available where technically feasible.
2. The bundles are offered for 2-, 3- and 5-year term commitments. A termination fee of 50% of the Monthly Recurring Charges will incur for the remainder of the term commitment period.
3. A customer may convert an existing term commitment to a new term commitment prior to the completion of the existing term without penalty. The customer will be charged subsequent service charges for the change and will pay the current rates in effect for the term commitment chosen.
4. When a customer's serving office is not suitably equipped and/or the customer chooses to subscribe to ISDN PRI Bundle Service from another central office, the customer will utilize the dialing plan associated with the designated ISDN PRI central office. For PRIs served from an alternate central office, the normal PRI rates will apply in addition to the charges for Special Transport Termination and Special Transport (Mileage).
5. ISDN PRI customers who are served from a foreign node may request to have their service provided from their local central office when facilities become available at that office. The Initial Service Ordering Charge and nonrecurring charges for T-1s and ports will be applicable, and termination charges will not apply on that transfer provided that the quantity of T-1s and ports are preserved. Customers who choose to continue service from a foreign node will be subject to the monthly rate for interoffice facilities. In addition, a number change generally will be required on any transfer from a foreign node to a local central office.
6. Ports will be provided at the T-1 level only.
7. Customer provided equipment used to connect to ISDN PRI Bundle Service must meet Company requirements.
8. The Company shall not be responsible to the customer if changes in any of the facilities, operations, or procedures utilized in the provision of ISDN PRI Bundle Service render any equipment provided by an end user obsolete or require any modification or alteration of such equipment or system or otherwise affect its use or performance.

(N)

Issued by authority of an Order of the Public Service Commission of West Virginia in Case No. 11-1139-T-T dated August 10, 2011.

Issued: August 2, 2011

Effective: August 16, 2011

GENERAL SERVICES TARIFF
P.S.C.-W.Va.-No. 203

Frontier West Virginia Inc.

Section 41
Original Page 2

INTEGRATED SERVICES DIGITAL NETWORK PRIMARY RATE INTERFACE BUNDLE SERVICE

(N)

B. REGULATIONS (Cont'd)

9. The customer must subscribe to services and specify each type of traffic that will be transported across the ISDN PRI Bundle Service port (i.e., DID, DOD). All rates and regulations for these services will apply. The bundle is offered as flat rate voice with measured data. Usage charges generated by using ISDN-PRI will be measured and billed in accordance with the rates specified in this tariff.
10. Appropriate nonrecurring charges apply for installation of and changes to ports, T-1s and features ordered by the customer except as set forth in C. following.

C. RATES

1. ISDN PRI Bundle Service is provided at the following rates:

	<u>Monthly Rate</u>
<u>2-Year Term</u> ¹	
ISDN-PRI Bundle ²	*
ISDN-PRI Bundle with 20 DID Numbers ²	*
ISDN-PRI Bundle with 50 DID Numbers ²	*
ISDN-PRI Bundle with 100 DID Numbers ²	*
<u>3-Year Term</u> ¹	
ISDN-PRI Bundle ²	*
ISDN-PRI Bundle with 20 DID Numbers ²	*
ISDN-PRI Bundle with 50 DID Numbers ²	*
ISDN-PRI Bundle with 100 DID Numbers ²	*
<u>5-Year Term</u> ¹	
ISDN-PRI Bundle ²	*
ISDN-PRI Bundle with 20 DID Numbers ²	*
ISDN-PRI Bundle with 50 DID Numbers ²	*
ISDN-PRI Bundle with 100 DID Numbers ²	*

¹ Nonrecurring Charges do not apply to the initial installation of an ISDN PRI Bundle.

² Channels activated for data will generate Usage Charges as set forth in Dedicated PRI Service, Section 14, Paragraph C. (Circuit-Switched Data Usage).

* Rates deregulated.

(N)

Issued by authority of an Order of the Public Service Commission of West Virginia in Case No. 11-1139-T-T dated August 10, 2011.

GENERAL SERVICES TARIFF
P.S.C.-W.Va.-No. 203

Frontier West Virginia Inc.

Section 42
1st Revised Page 1
Cancels Original Page 1

FRONTIER SIMPLY UNLIMITED SERVICE-LEADER ¹

(C)

A. GENERAL

1. Frontier Simply Unlimited Service-Leader is a bundled offering available to Business customers that subscribe to a maximum of twelve Single Party Business Lines per customer location. The package includes a flat rate Basic Business Line (Plan 2), a combination of enhanced calling features, certain designated non-regulated services and price-listed services. The bundle also includes the End User Subscriber Line Charge and Access Recovery Charge from the federal tariff in addition to the features and services listed below.

Basic Bundle

One-Party Flat Rate Business Access Line (Plan 2)
Call Forwarding (associated with Voice Mail)
Caller ID Name and Number
Frontier Business Deluxe Voice Mail (non-regulated)
Eight features from the Frontier Business All In Feature Package listed below

Frontier Business All In Feature Package

*69
Busy Redial
Call Forwarding Busy/No Answer-Fixed
Call Forwarding Busy Line-Fixed
Call Forwarding No Answer-Fixed
Call Waiting/Cancel Call Waiting
Distinctive Ring
Selective Call Rejection
Speed Dialing 8
Speed Dialing 30
Three Way Calling
VIP Alert

All of these features can be added to the bundle for the rate specified in C.

B. REGULATIONS

1. The bundle is available only where facilities and operating systems are available and technically feasible.
2. The features are provided subject to their individual service regulations as specified in the applicable schedules of the tariff.

¹ Effective January 20, 2018 this service offering is limited to existing subscribers.

(N)
(N)

Issued by authority of an Order of the Public Service Commission of West Virginia in Case No. 18-0013-T-T dated January 19, 2018.

GENERAL SERVICES TARIFF
P.S.C.-W.Va.-No. 203

Frontier West Virginia Inc.

Section 42
1st Revised Page 2
Cancels Original Page 2

FRONTIER SIMPLY UNLIMITED SERVICE-LEADER ¹

(C)

B. REGULATIONS (Cont'd)

3. Frontier Simply Unlimited Service-Leader includes basic local service and non-basic local services. Non-payment or partial payment of the bill may result in the cancellation of the bundled package and all services will be charged their individual tariffed rate. Payment will then be applied in accordance with existing Commission Rules and Regulations for the Government of Telephone Utilities.
4. Customers may add or delete any features offered within the bundle without incurring a Service Connection Charge.
5. The bundle cannot be used in association with a Residential Line, PBX Service, ISDN Service, Toll Free Service, Remote Call Forwarding Service and Foreign Exchange Services.
7. The bundle is offered on a month to month basis.
7. Up to eleven additional bundles can be purchased at the rates specified in C. Bundles four through twelve are given an additional discount.

C. RATES

1. The Federal End User Subscriber Line Charge and the Access Recovery Charge are included in the bundle offering. Other applicable surcharges and taxes will be billed separately from and are in addition to the bundle rate.
2. Unless otherwise stated elsewhere in this section, Connection Charges apply to the installation of individual components of the bundle.
3. Frontier Simply Unlimited Service-Leader is provided at the following rates:

	<u>Monthly Rate</u>
Frontier Simply Unlimited Service-Leader, Bundle 1-3	*
Frontier Simply Unlimited Service-Leader, Bundle 4-12	*
Frontier Business All In Feature Package	*

* Rates deregulated.

¹ Effective January 20, 2018 this service offering is limited to existing subscribers.

(N)
(N)

Issued by authority of an Order of the Public Service Commission of West Virginia in Case No. 18-0013-T-T dated January 19, 2018.

Issued: January 5, 2018

Effective: January 20, 2018

GENERAL SERVICES TARIFF
P.S.C.-W.Va.-No. 203

Frontier West Virginia Inc.

Section 43
1st Revised Page 1
Cancels Original Page 1

FRONTIER SIMPLY UNLIMITED SERVICE-CHALLENGER ¹

(C)

A. GENERAL

1. Frontier Simply Unlimited Service-Challenger is a bundled offering available to Business customers that subscribe to a maximum of twelve Single Party Business Lines per customer location. The package includes a flat rate Basic Business Line (Plan 2), a combination of enhanced calling features, certain designated non-regulated services and price-listed services. The bundle also includes the End User Subscriber Line Charge and Access Recovery Charge from the federal tariff in addition to the features and services listed below.

Basic Bundle

One-Party Flat Rate Business Access Line (Plan 2)
Call Forwarding (associated with Voice Mail)
Caller ID Name and Number
Frontier Business Deluxe Voice Mail (non-regulated)
Four features from the Frontier Business All In Feature Package listed below

Frontier Business All In Feature Package

*69
Busy Redial
Call Forwarding Busy/No Answer-Fixed
Call Forwarding Busy Line-Fixed
Call Forwarding No Answer-Fixed
Call Waiting/Cancel Call Waiting
Distinctive Ring
Selective Call Rejection
Speed Dialing 8
Speed Dialing 30
Three Way Calling
VIP Alert

All of these features can be added to the bundle for the rate specified in C.

B. REGULATIONS

1. The bundle is available only where facilities and operating systems are available and technically feasible.
2. The features are provided subject to their individual service regulations as specified in the applicable schedules of the tariff.

¹ Effective January 20, 2018 this service offering is limited to existing subscribers.

(N)
(N)

Issued by authority of an Order of the Public Service Commission of West Virginia in Case No. 18-0013-T-T dated January 19, 2018.

GENERAL SERVICES TARIFF
P.S.C.-W.Va.-No. 203

Frontier West Virginia Inc.

Section 43
1st Revised Page 2
Cancels Original Page 2

FRONTIER SIMPLY UNLIMITED SERVICE-CHALLENGER ¹

(C)

B. REGULATIONS (Cont'd)

3. Frontier Simply Unlimited Service-Challenger includes basic local service and non-basic local services. Non-payment or partial payment of the bill may result in the cancellation of the bundled package and all services will be charged their individual tariffed rate. Payment will then be applied in accordance with existing Commission Rules and Regulations for the Government of Telephone Utilities.
4. Customers may add or delete any features offered within the bundle without incurring a Service Connection Charge.
5. The bundle cannot be used in association with a Residential Line, PBX Service, ISDN Service, Toll Free Service, Remote Call Forwarding Service and Foreign Exchange Services.
8. The bundle is offered on a month to month basis.
7. Up to eleven additional bundles can be purchased at the rates specified in C. Bundles four through twelve are given an additional discount.

C. RATES

1. The Federal End User Subscriber Line Charge and the Access Recovery Charge are included in the bundle offering. Other applicable surcharges and taxes will be billed separately from and are in addition to the bundle rate.
2. Unless otherwise stated elsewhere in this section, Connection Charges apply to the installation of individual components of the bundle.
3. Frontier Simply Unlimited Service-Challenger is provided at the following rates:

	<u>Monthly Rate</u>
Frontier Simply Unlimited Service-Challenger, Bundle 1-3	*
Frontier Simply Unlimited Service-Challenger, Bundle 4-12	*
Frontier Business All In Feature Package	*

* Rates deregulated.

¹ Effective January 20, 2018 this service offering is limited to existing subscribers.

(N)
(N)

Issued by authority of an Order of the Public Service Commission of West Virginia in Case No. 18-0013-T-T dated January 19, 2018.

FRONTIER ONEVOICE

(N)

A. GENERAL

1. Frontier OneVoice is a bundled offering available to Business customers that subscribe to Single Party Business Line. The bundle includes the following components: one flat rate Basic Business Line (Plan 2), Custom Calling features, and Unlimited Extended Area Service. Customers may select any or all of the following services and features for a monthly rate charge.

Basic Bundle

One-Party Flat Rate Business Access Line (Plan 2)
Call Forwarding Busy/No Answer
Unlimited Extended Area Service
Call Waiting/Cancel Call Waiting
Caller ID Name and Number
Anonymous Call Rejection
Call Forward
Multi-line Hunting
3-Way Calling

Premium Feature Package

Call Return (*69)
Call Transfer
Distinctive Ring
Busy Number Redial (*66)
Priority Call
Selective Call Forward
Selective Call Acceptance
Selective Call Rejection
Speed Call 30

All of these features can be added to the bundle for the rate specified in C.

B. REGULATIONS

1. The bundle is available only where facilities and operating systems are available and technically feasible.
2. The features are provided subject to their individual service regulations as specified in the applicable schedules of the tariff.
3. Call Detail for Unlimited Extended Area Service will not be displayed on the customer's monthly telephone bill.
4. Partial payment of the basic local service charge within the bundle may result in disconnection of the customer's basic local service.

(N)

Issued by authority of an Order of the Public Service Commission of West Virginia in Case No. 15-1495-T-T dated September 16, 2015.

GENERAL SERVICES TARIFF
P.S.C.-W.Va.-No. 203

Frontier West Virginia Inc.

Section 44
2nd Revised Page 2
Cancels 1st Revised Page 2

FRONTIER ONEVOICE

B. REGULATIONS (Cont'd)

5. Customers may add or delete any features offered within the bundle without incurring a Service Connection Charge.
6. The bundle rate will appear as a single line item on the customer's bill.
7. The bundle is available only to customers who are served from a central office in which services in the bundle are offered and can be provided by the Company to the customer.
8. The bundle cannot be used in association with a Residential Line, Remote Call Forwarding Service, ISDN Service, Centrex or Foreign Exchange Services.
9. The bundle is offered on a month-to-month or one year term basis. (C)

C. RATES

1. Surcharges and taxes will be billed separately from and are in addition to the bundle rate.
2. New customers will incur a nonrecurring charge up to * per account. This charge supersedes Service Charges.

Monthly Rate

Basic Bundle Month-to-Month	*	
Basic Bundle One Year Term Commitment	*	(C)
Premium Feature Package	*	

* Rates deregulated.

Issued by authority of an Order of the Public Service Commission of West Virginia in Case No. 24-0246 T-T dated February 28, 2024, effective March 8, 2024.

Issued: February 23, 2024

Effective: March 8, 2024

GENERAL SERVICES TARIFF
P.S.C.-W.Va.-No. 203

Frontier West Virginia Inc.

Section 45
1st Revised Page 1
Cancels Original Page 1

FRONTIER COMMERCIAL VOICE UNLIMITED ¹

(C)

A. GENERAL

1. Frontier Commercial Voice Unlimited is a bundled offering available to Business customers that subscribe to a maximum of twelve Single Party Business Lines per customer location. The bundle includes the following components: one flat rate Basic Business Line (Plan 2), Custom Calling features, and Unlimited Extended Area Service. The bundle also includes the Subscriber Line Charge and the Access Recovery Charge that is tariffed in the appropriate FCC tariff.

Basic Bundle

One-Party Flat Rate Business Access Line (Plan 2)
Unlimited Extended Area Service
Call Forward
Call Forwarding Busy
Call Forwarding No Answer
Call Waiting/Cancel Call Waiting
Caller ID
Call Waiting ID
Three-way Calling
Hunting

B. REGULATIONS

1. The bundle is available only where facilities and operating systems are available and technically feasible.
2. The features are provided subject to their individual service regulations as specified in the applicable schedules of the tariff.
3. Call Detail for Unlimited Extended Area Service will not be displayed on the customer's monthly telephone bill.
4. Frontier Commercial Voice Unlimited includes basic local service and non-basic local services. Nonpayment or partial payment of the basic local service charge within the bundle may result in disconnection of the customer's basic local service.
5. Customers may add or delete any features offered within the bundle without incurring a Service Connection Charge.
6. The bundle rate will appear as a single line item on the customer's bill.
7. The bundle is available only to customers who are served from a central office in which services in the bundle are offered and can be provided by the Company to the customer.

¹ Effective January 20, 2018 this service offering is limited to existing subscribers.

(N)
(N)

Issued by authority of an Order of the Public Service Commission of West Virginia in Case No. 18-0013-T-T dated January 19, 2018.

GENERAL SERVICES TARIFF
P.S.C.-W.Va.-No. 203

Frontier West Virginia Inc.

Section 45
1st Revised Page 2
Cancels Original Page 2

FRONTIER COMMERCIAL VOICE UNLIMITED ¹

(C)

B. REGULATIONS (Cont'd)

8. The bundle cannot be used in association with a Residential Line, PBX Service, Remote Call Forwarding Service, ISDN Service, Toll Free Service or Foreign Exchange Services.
9. The bundle is offered on a month-to-month or one year term basis.
10. Customers in a term plan will be charged a termination fee for cancelling before the term is up. The early termination fee is the monthly charge times the remaining months in the term.
11. At the end of the one year term, customers will be moved to the month-to-month pricing.

C. RATES

1. Interstate End User Subscriber Line Charge and Access Recovery Charge are included in the bundle. Other applicable surcharges and taxes will be billed separately from and are in addition to the bundle rate.
2. Unless otherwise stated elsewhere in this section, Connection Charges apply to the installation of the bundle.

	<u>Monthly Rate</u>
Basic Bundle Month-to-Month	*
Basic Bundle One Year Term	*

* Rates deregulated.

¹ Effective January 20, 2018 this service offering is limited to existing subscribers.

(N)
(N)

Issued by authority of an Order of the Public Service Commission of West Virginia in Case No. 18-0013-T-T dated January 19, 2018.

